



Thank You for purchasing this

Factory Service Manual on EBAY

from PCTECHINFO!



[Click Here](#) for more Factory Service

Manuals for other Computer and

Printer / Copier Manufacturers

from PCTECHINFO!



OKIDATA

Service Guide



Pacemark 4410

The PACEMARK® 4410 is simply the most reliable, powerful and durable forms printer in its class. Stand-alone or shared by a workgroup, this heavy-duty impact printer can tackle your most demanding forms work-flow and then some.

Adobe Acrobat printable reference copy
of the OKIDATA Service Training Manual.
05/13/98

Note: This Adobe Acrobat version of the Okidata Service Training Manual was built with the pictures rendered at 300 dpi, which is ideal for printing, but does not display well on most displays.

Service Guide for PM4410

0 Introduction

Preface	1
---------	---

1 Specifications

1.1 Basic System Configuration	2
1.2 Printer Specifications	3
1.3 Option Specifications	4
1.4 Basic Specifications	5

2 Operation

2.1 Electrical Operation	6
....2.1.1 Summary	7
....2.1.2 Microprocessor and the peripheral circuit	8
....2.1.3 Initialization	9
....2.1.4 Interface Control	10
....2.1.5 Parallel Interface Control	11
....2.1.6 Serial Interface	12
....2.1.7 Printing Operation	13
....2.1.8 Printhead control	14
....2.1.9 Print Compensation Control	15
....2.1.10 Space motor control	16
....2.1.11 Line feed	17
....2.1.12 Bail, tractor, switching, AG, ribbon motor control	18
....2.1.13 Operation Panel	19
....2.1.14 Alarm circuit	20
....2.1.15 Power supply circuit	21
2.2 Mechanical Operation	22
....2.2.1 Printhead mechanism and operation	23
....2.2.2 Spacing operation	24
....2.2.3 Head gap adjusting	25
....2.2.4 Ribbon drive	26
....2.2.5 Paper Feed Mechanism	27
....2.2.6 Bail Feed Mechanism	28
....2.2.7 Paper End Detection Mechanism	29

3 Disassembly

3.1 Precautions for Parts Replacement	30
3.2 Parts Layout	31
3.3 How to Change Parts	32
....3.3.1 Cover-Assy-Access / Cover-Assy-Side (R) / Cover-Assy-Side (L) / Cover-Assy-Front / Frame-Assy-Rear / Plate-Front (stuck)	33
....3.3.2 Printer Unit	34
....3.3.3 Control Block [Control Board (PMA Printed Board), Driver Board (PDA Printed Board)]	35
....3.3.4 Power Supply Unit	36
....3.3.5 PG Cooling Fan	37
....3.3.6 I/F Board (PHA Printed Board)	38
....3.3.7 AG Board (PGA Printed Board) / Connector Cord	39
....3.3.8 AG Motor Assy	40
....3.3.9 Mini Pitch Belt	41
....3.3.10 Tractor Change Motor Assy	42
....3.3.11 Bail Motor Assy	43
....3.3.12 LF Motor Assy	44
....3.3.13 Head Cooling Fan 1	45
....3.3.14 Head Cooling Fan 2	46
....3.3.15 Space Motor	47
....3.3.16 Operator Board (POA Printed Board)	48
....3.3.17 Ribbon Feed Assy	49
....3.3.18 Printing Head	50
....3.3.19 Head Cable	51
....3.3.20 Ribbon Protector	52
....3.3.21 Space Motor Fan	53
....3.3.22 Junction Board	54
....3.3.23 Cover Open Switch Assy / Ribbon Rotation Sensor	55
....3.3.24 Interlock Switch / Interlock Switch Cord Assy	56
....3.3.25 Knob Bracket Assy	57
....3.3.26 Space Belt	58
....3.3.27 AG Sensor Frame / Start Searching Sensor	59

Table of Contents	Page
....3.3.28 Paper Jam Sensor Assy / Bail PE Sensor Assy	60
....3.3.29 Sprocket Assy (L) (R) (Front Tractor)	61
....3.3.30 Sheet Feeder Assy (L) Rear / Sheet Feeder Assy (R) Rear	62
....3.3.31 Bail Assy	63
4 Adjustments	
Adjustments	64
5 Maintenance	
5.1 Cleaning	65
5.2 Lubrication	66
....(28) Option Interface	67
6 Maintenance	
6.1 Items to Check Before Repair	68
6.2 Troubleshooting Table	69
6.3 Lamp and LCD Display	70
6.4 Part Layout	71
6.5 Connection	72
....(1) Printhead	73
....(2) Line feed motor	74
....(3) Space motor	75
....(4) Ribbon motor	76
....(5) Path-change motor	77
....(6) Auto-gap motor	78
....(7) Bail motor	79
....(8) Space Fan1	80
....(9) Space Fan2	81
....(10) Head Fan1	82
....(11) Head Fan2	83
....(12) Power Fan	84
....(13) Space slit sensor	85
....(14) Auto-gap sensor	86
....(15) Cover Open Switch / Ribbon Jam Sensor	87
....(16) Optical Sensor	88
....(17) Sheet Top Locating Sensor / Auto Gap Core	89
....(18) Paper Jam Sensor / Bail Paper End Sensor	90
....(19) Bail Open Switch / Front Tractor On Switch	91
....(20) Front Tractor Paper End Switch	92
....(21) Rear Tractor Paper End Switch	93
....(22) Power Supply Unit	94
....(23) Operation Panel	95
....(24) Standard Interface	96
....(25) Short Plug	97
....(26) Others	98
....(27) MUPIS Interface (Option)	99
....(29) Continuous-Form Paper Cutter (Option)	100
7 Troubleshooting	
Troubleshooting	101
....(1) Printer is not powered on at all	102
....(2) Printer does not operate at all, while Power Lamp is on, Alarm Lamp blinks and nothing is displayed on LCD	103
....(3) Printer does not operate at all, while Power Lamp is on, Alarm Lamp is on/off and nothing is displayed on LCD	104
....(4) Spacing is abnormal, while Alarm Lamp is on and "ERROR HOMING" or "ERROR SPACING" is displayed on LCD	105
....(5) Carriage does not operate at all, while the Alarm Lamp is on and "ERROR AUTOGAP" is displayed on LCD	106
....(6) After Carriage works, Alarm Lamp goes on and "ERROR (in the upper row, BAIL (in the lower))" is displayed on LCD	107
....(7) After Carriage operates, Alarm Lamp goes on and "ERROR (in the upper row), PATH CHANGE (in the lower)" is displayed on LCD	108
....(8) After initialization, Alarm Lamp goes on and "ERROR (in the upper row), RIBBON JAM (in the lower)" is displayed on LCD	109
....(9) Paper is not line fed, while the Alarm Lamp is on and "ERROR (in the upper row), FEED JAM (in the lower)" is displayed on LCD	110
....(10) Papers line fed, but "FEED JAM" is displayed on LCD	111
....(11) Printer does not operate at all, while the Alarm Lamp is on and "ERROR FUSE" is displayed on LCD	112

Table of Contents**Page**

....(12) Printer goes off during operation	113
....(13) Printer does not operate after being turned on, while "INITIALIZING" is displayed on LCD	114
....(14) Wrong characters are printed or characters are omitted	115
....(15) Printer operates normally but characters are not printed	116
....(16) Printer operates normally but characters are not printed.	117
....(17) Printer operates normally but characters are not printed. (With MUPIS Card used)	118
....(18) Dots are omitted	119
....(19) Images are faint	120
....(20) After Carriage works, the Alarm Lamp goes on and "ERROR AUTOGAP" is displayed on LCD	121
....(21) Paper is set at Tractor, but printing is not conducted in the state of "PAPER END"	122
....(22) "COVER OPEN" is displayed on LCD even though Access Card is closed	123
....(23) Pressing Operation Panel Switches does not make Printer operate (after normal initialization)	124
....(24) "ERROR, D-RAM" is displayed on LCD, while Alarm Lamp blinks	125
....(25) "ERROR, PROGRAM-ROM" is displayed on LCD, while Alarm Lamp blinks	126
....(26) "ERROR, EEPROM" is displayed on LCD, while Alarm Lamp blinks	127
....(27) "ERROR, S-RAM" is displayed on LCD, while Alarm Lamp blinks	128
....(28) "ERROR, CG-ROM" is displayed on LCD while Alarm Lamp blinks	129
....(29) "ERROR, CENTERING" is displayed on LCD, while Alarm Lamp blinks	130
8 Parts List	
Total Assembling Diagram	131
Printer Unit (1 of 3)	132
Printer Unit (2 of 3)	133
Printer Unit (3 of 3)	134
Carriage Assembly	135
Knob Assembly	136
Ribbon Assembly	137
Sprocket Assembly (L)	138
Sprocket Assembly (R)	139
Sheet Feeder Assembly (L) Rear	140
Sheet Feeder Assembly (R) Rear	141
Bail Assembly	142
Lower Cover Assembly	143
Front Cover Assembly	144
Rear Cover Assembly	145
Access Cover	146
Frame Assembly - OpePane	147
PMA/PDA PCB Assembly	148
A PCB Layout	
(1) Circuit board PMA (Control)	149
(2) Circuit board PDA (Driver)	150
(3) Circuit board POA (Operation Panel)	151
(4) Circuit board PHA (Interface)	152
(5) Circuit board PRA (Connection)	153
(6) Circuit board PGA (Sensor)	154
B RS-232C Serial Interface Board	
1. General	155
2. Operation Description	156
....2.1 Element Description	157
....2.2 Circuit Description	158
.....2.2.1 Operation at power on	159
.....2.2.2. RS-232C interface	160
....2.3 Local Test	161
.....2.3.1 Circuit test mode	162
.....2.3.1.1 Setting	163
.....2.3.1.2 Function	164
C Maintenance Support Function	

Table of Contents**Page**

1. Normal mode	165
2. Maintenance mode 1	166
3. Maintenance mode 2	167
4. Maintenance function	168
....4.1 Auto gap test	169
....4.2 Gap close	170
....4.3 Sensor slice level learning function	171
....4.4 All sensors ON/OFF check function	172
....4.5 Print start position PE sensor aligning function	173
....4.6 FLASH memory loading function	174
....4.7 Head pin test	175
....4.8 AG correction function	176
....4.9 AG adjustment aid function	177
....4.10 Autogap Open/Close Test	178
....4.11 Aging Function	179



Service Guide for PM4410 Chapter 0 Introduction

Page: 1

Preface

This maintenance manual describes how to maintain the Pacemark 4410 printer in the field.

This manual is for customer engineers.

For further information, refer to the User's Manual for handling or operating the equipment.

Copyright 1998, Okidata, Division of OKI America, Inc. All rights reserved. See the OKIDATA Business Partner Exchange (BPX) for any updates to this material. (<http://bpx.okidata.com>)

Service Guide for PM4410 Chapter 1 Specifications

1.1 Basic System Configuration

The basic system configuration of Pacemark 4410 is illustrated below in Figure 1-1.

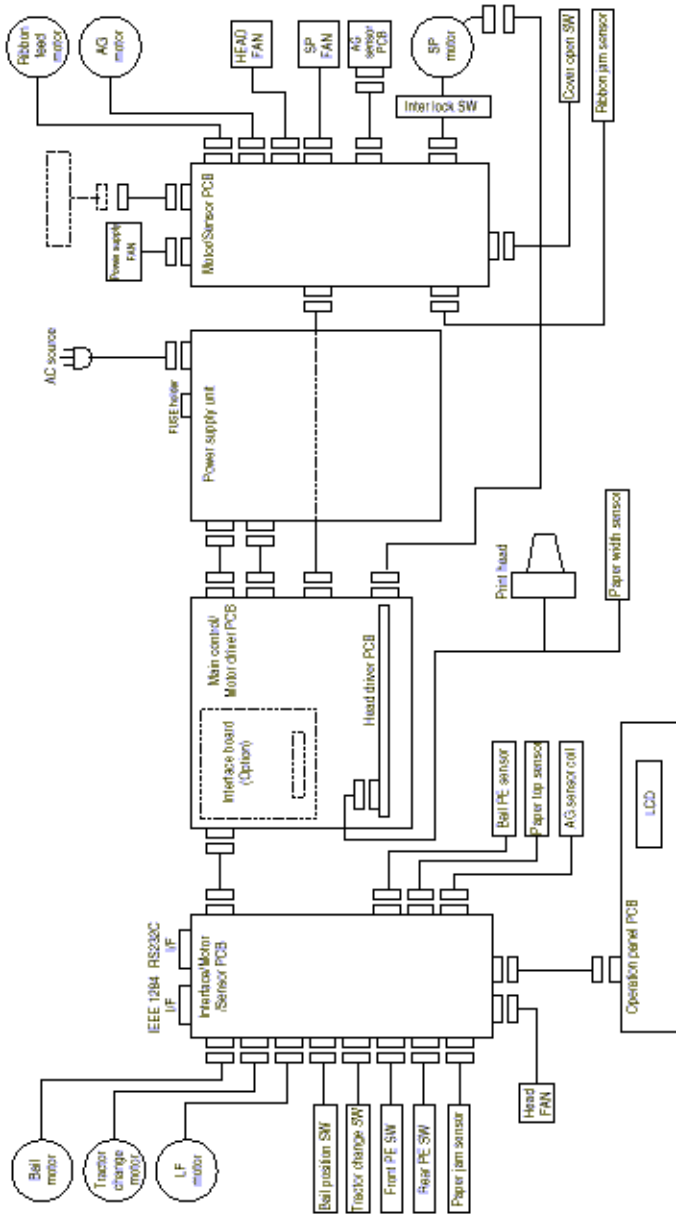

Figure 1.1

1.2 Printer Specifications

This printer unit is composed with the following hardware.

- Printer mechanism
- Main control/Motor driver board
- Head driver board
- Interface/Motor/Sensor board (including IEEE 1284 bi-directional parallel interface and RS-232C serial interface)
- Motor/Sensor and AG sensor boards
- Operation panel board
- Power supply unit
- Covers

Figure 1-2 show the printer unit configuration.

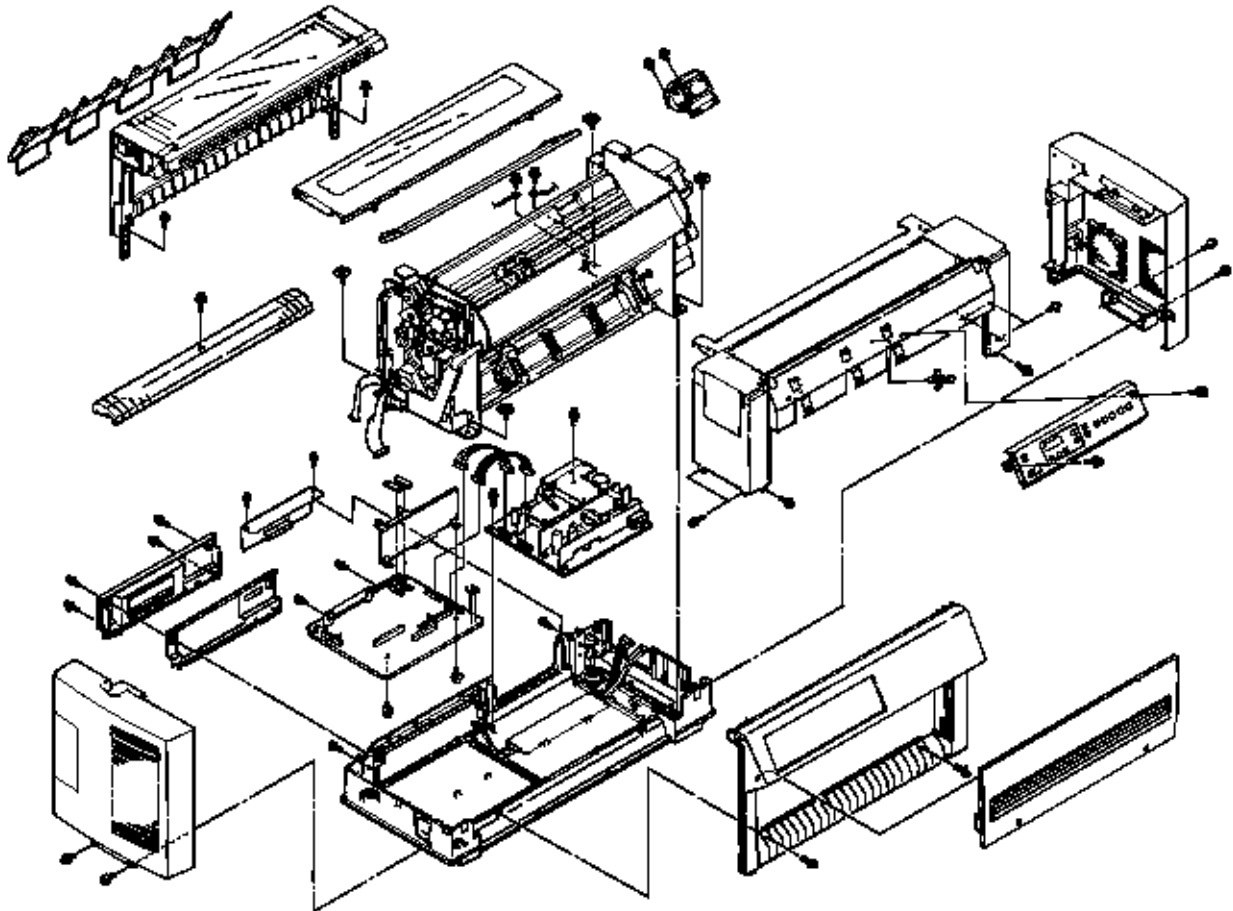

Figure 1.2

Copyright 1998, Okidata, Division of OKI America, Inc. All rights reserved. See the OKIDATA Business Partner Exchange (BPX) for any updates to this material. (<http://bpx.okidata.com>)

1.3 Option Specifications

Options available for Pacemark 4410 are as follows.

(1) Interface boards

(a) 70034401 OkiLAN 6010e Pocket Printer Server

(b) 70034201 OkiLAN 6100e 10/100 Base-TX Ethernet Internal Print Server

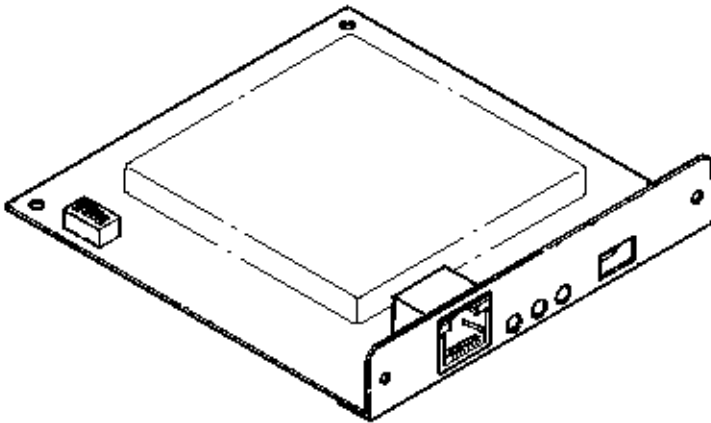

(b) Okidata Microline 300/500 Series Serial/ HSP Adapter

- RS422A
- Current Loop

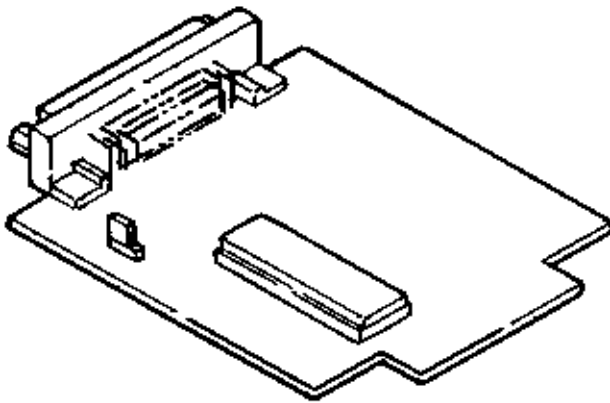



Service Guide for PM4410 Chapter 1 Specifications

1.4 Basic Specifications

(1) Dimensions

Width: 768mm (30.24 inches) Length: 385mm (15.16 inches) Height: 358mm (14.09 inches)

(2) Weight

Approx. 42kg (92.6 lbs.)

(3) Form

Continuous Paper

One-part paper

Ream weight: 45 to 90g/m² (12 to 24 lbs.)

Multiple-part paper Max. 0.79mm 0.031 inches total thickness (with front feed)

Max. 0.36mm (0.014 inches) total thickness (with rear feed)

Paper type	Ream weight	Number of sheet
Carbon-lined paper Pressure-sensitive paper	35 to 40 g/m ² (9 to 11 lbs.)	Ten sheet maximum including original (with front feed)
Interleaf paper	Paper 35 to 52 g/m ² (9 to 14 lbs.) Carbon paper 34 g/m ² (9 lbs.)	Seven sheets maximum including original (with front feed) Four sheet maximum including original (with rear feed)

When 7 parts or more papers are used for the front tractor, "High Impact Copy" should be selected in the menu mode to print these papers.

Continuous Envelope

Weight : Max. 90 g/m² 24 lbs

Thickness : Max. 0.36mm (0.014 inch)

Width : 76.2 - 254mm (3 - 10 inches)

Media supply : Front paper feed only

Card

Weight : Max. 375 g/m² 100 lbs.

Thickness : Max. 0.20mm (0.008 inch)

Size : 5 x 8 inches (separated)

Media supply : Front paper feed only

Label

Thickness : Max 0.28mm (0.011 inch)

Size : Max. 381 x 83mm (15 x 3.25 inches)

Media supply : Front paper feed only

(4) Print speed

Print Mode	10 CPI	12 CPI	15 CPI	17.1 CPI	20 CPI
HSD	1066 CPS	1066 CPS	1066 CPS	1066 CPS	1066 CPS
NLQ	200 CPS	200 CPS	200 CPS	200 CPS	200 CPS
UTILITY	800 CPS	800 CPS	800 CPS	800 CPS	800 CPS

(5) Maximum Number of Dot Columns per Line

a) Graphics

Single Density	Double Density	Quadruple Density
816	1,632	3,264

b) Text

Print Mode	10 CPI	12 CPI	15 CPI	17.1 CPI	20 CPI
HSD	1066 CPS	1066 CPS	1066 CPS	1066 CPS	1066 CPS
NLQ	200 CPS	200 CPS	200 CPS	200 CPS	200 CPS
UTILITY	800 CPS	800 CPS	800 CPS	800 CPS	800 CPS

(6) Maximum Number of Characters per Line

Character pitch (CPI)	5	6	7.5	8.5	10	12	15	17.1	20
ML EPSON IBM	68	81	102	116	136	163	204	233	272

(7) Printhead

Print method: Impact dot matrix

Number of dot wires: 9 wires x 2 rows

Dot wire diameter: 0.36mm 0.014 inch

(8) Line feed Speed

6 LPI spacing, one LF = 60 ms

8 LPI spacing, one LF = 52 ms

Continuous paper feed rate is 15 inches per second. (at head gap 1, 2)

(9) Line Feed Pitches

6 LPI 0.167 inch (4.23mm)

8 LPI 0.125 inch (3.175mm)

A variable line feed pitch of $n/216$ inch (integer n : $0 \leq n \leq 255$) can also be specified. Also,

$7/72$ inch and $n/72$ inch can be specified.

PROPRINTER n : 1 ≤ n ≤ 255

EPSON n : 1 ≤ n ≤ 255 (Cannot specify MSB : 1 ≤ n ≤ 127)

(10) Power Requirements

a) Input power

Single-phase AC

Voltage : 120VAC +5.5%, -15%

230 VAC ±15%

Frequency : 50/60Hz ±2%

b) Power consumption

Local Test : Max. 295 W (Rolling ASCII, Utility)

Idle : Max. 15W (Energy Star compliant)

c) AC power cable

Length : Approximately 5.9 ft (1.8 m)

Cable conforms to the UL, CSA, and European Standards.

Note: AC power cable is not supplied.

(11) Ambient temperature and relative humidity

	Operating	Non-operating	Storage	Transportation	Unit
Temperature	41 to 95 (5 to 35)	32 to 109.4 (0 to 43)	14 to 122 (-10 to 50)	-40 to 158 (-40 to 70)	°F (°C)
Relative Humidity	20 to 80	10 to 90	5 to 95	5 to 95	% RH

Avoid condensation at all times.

(12) Vibration

Operating : Max. 0.3G (5 to 150 Hz) (except at resonant frequency)

Non-operating : Max. 1G (5 to 150 Hz) (except at resonant frequency)

(13) Impact (Drop Test)

Packing : 12" Drop

(14) Noise

The 8-second average noise is Max. 55 dBA in quiet utility mode. (ISO 7779)

(15) Ribbon

Genuine OKI cartridge ribbon

Ink color : Black

Ribbon life : Approximately 15 million characters (Characters in Utility mode)

(16) Reliability

a) MTBF (mean time between failures)

12,000 hours of power-on time at 25% duty cycle and 35% page density.

b) Printhead life

400 million characters (average) in 10 CPI Utility print mode at 25% duty cycle and 35% page density.

c) Printer life

12,000 hours of power-on time at 25% duty cycle and 35% page density, or 5 years.

d) MTTR

15 minutes, major Sub-assembly level.

Definition of terms

- Duty cycle : Actual operation rate
- Page density : the proportion in area of characters and spaces within printhead movable area.
- Power on Time : 8 hours/day, 25 days/month and 12 months/year.



2.1 Electrical Operation

The electrical operation of the printer circuit is described in this section.

2.1.1 Summary

2.1.2 Microprocessor and the peripheral circuit

2.1.3 Initialization

2.1.4 Interface control

2.1.5 Parallel Interface Control

2.1.6 Serial Interface

2.1.7 Printing operation

2.1.8 Printhead control

2.1.9 Print Compensation Control

2.1.10 Space motor control

2.1.11 Line feed

2.1.12 Bail, tractor switching, AG, ribbon motor control

2.1.13 Operation Panel

2.1.14 Alarm circuits

2.1.15 Power supply circuit



Service Guide for PM4410 Chapter 2 Operation

2.1.1 Summary

Fig. 2-1 (shown in next section) shows the block diagram of the printer.

The control board is made up of the microprocessors, peripheral circuits, drive circuits, sensors and interface connectors.

The power to the control board is supplied by the power board through the connector cord.

The power to other electrical parts is also distributed through the connectors within the control board.

Copyright 1998, Okidata, Division of OKI America, Inc. All rights reserved. See the OKIDATA Business Partner Exchange (BPX) for any updates to this material. (<http://bpx.okidata.com>)



2.1.2 Microprocessor and the peripheral circuit

(1) Microprocessor (IC24: 80C186-16)

This processor is a CMOS single-chip computer with integrated peripheral device functions and a 16 bit MPU core.

The processor has a 20 bit address bus and a 16 bit data bus.

It is capable of accessing up to 4M bit program memory and 4M bit of data memory.

The following characteristics are also provided:

- High-Speed DMA Channel x 2
- Programmable Interrupt Controller
- Programmable 16-bit Timer x 3
- Programmable Memory and Peripheral Chip-Select Logic
- Programmable Wait State Generator
- Local Bus Controller

And others.

The function of this microprocessor is to provide a central mechanism for the entire printer by executing the control program through the LSI and driver circuits.

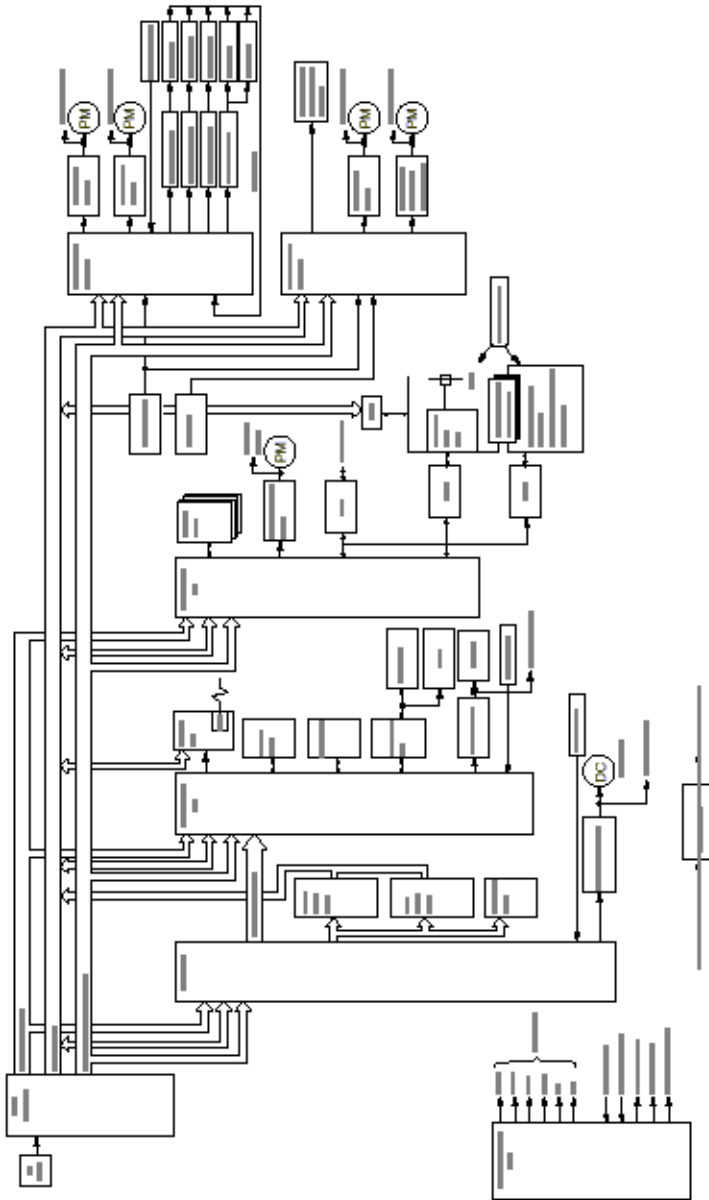

Figure 2.1

(2) PG ROM (IC46)

This is a 256 x16 bits (4M bit) EPROM with the control program for the printer stored. The MPU executes instructions under this program.

The program ROM is assigned to the program memory area of the MPU and is fetched by the RD signal of the MPU.

The following shows the operation of the memory access.

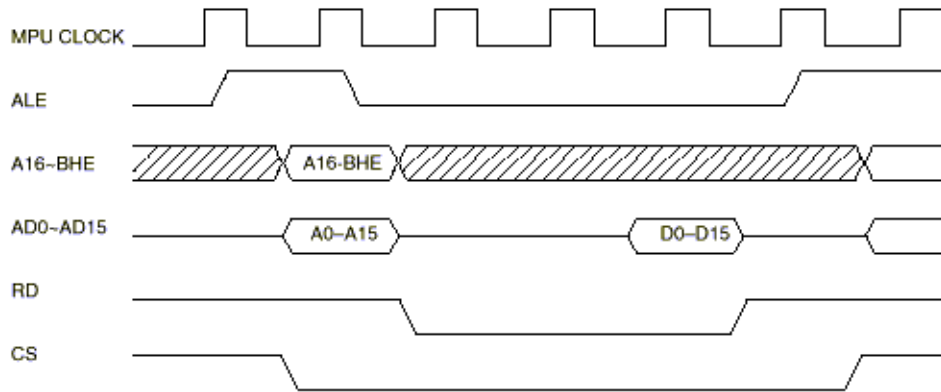
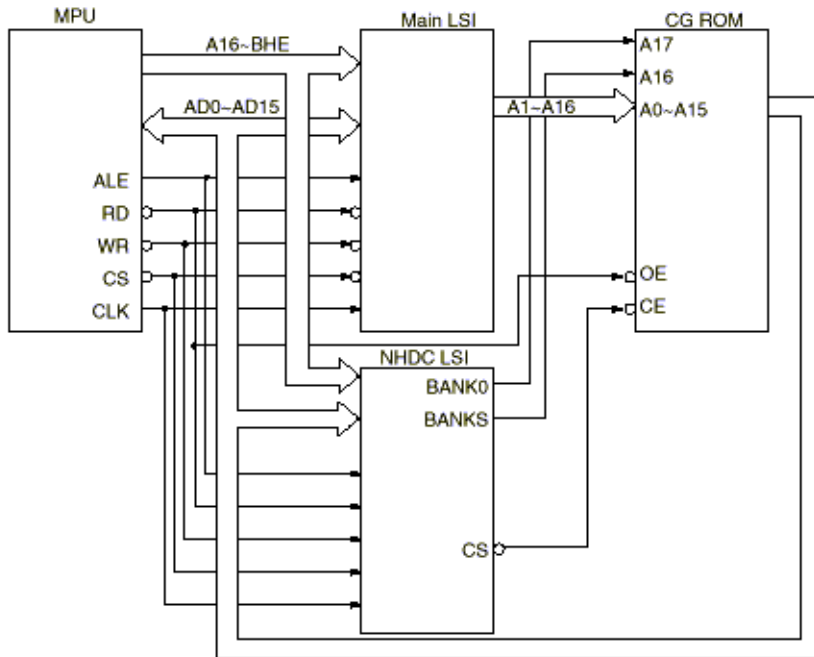
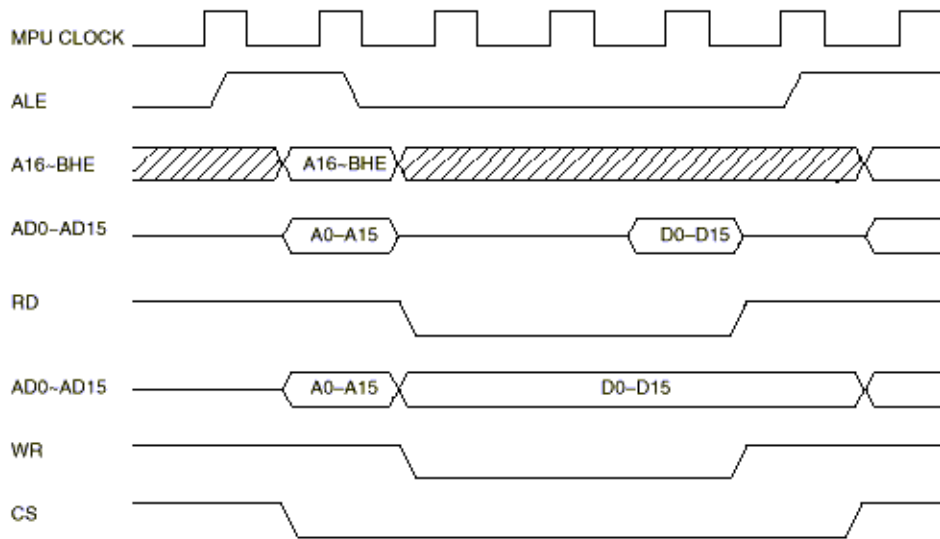
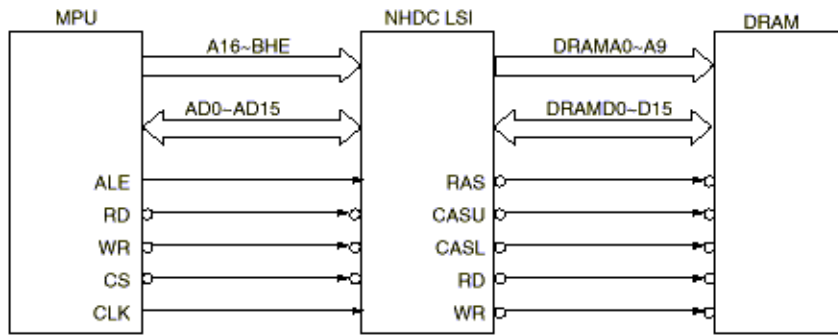

Figure 2.2

(3) DRAM(IC28)

The RAM is CMOS dynamic RAM with (256K x 16 bit) configuration, and used as buffers (such as receiving buffer, printing buffer, DLL buffer and working buffer).

The following shows the examples of the memory access operation.



(4) CG ROM (IC48)

This is a 256K x 16 bits (4M bits) EPROM with the font data for the characters stored.

CG ROM is assigned to the program memory area of the MPU and is fetched by the RD signal of the MPU.

The following shows the memory access operation.

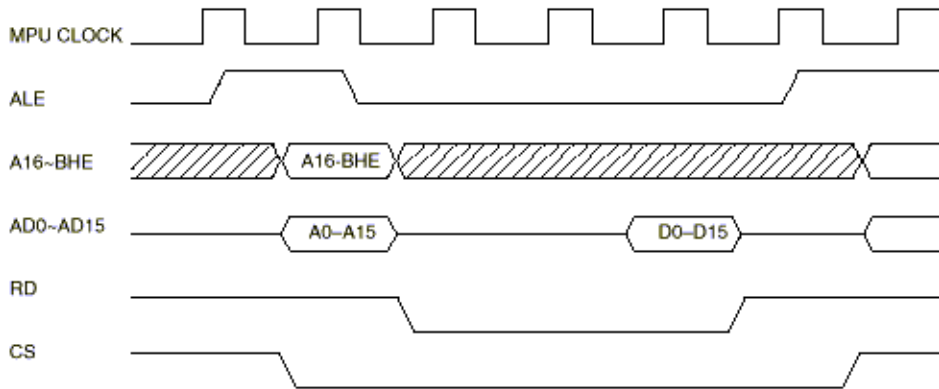
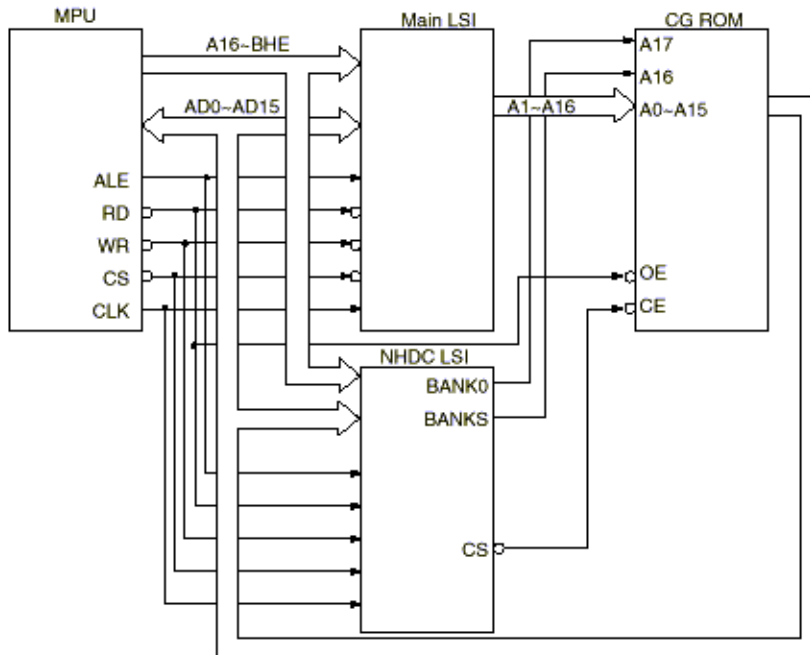

Figure 2.4

(5) EEPROM(IC40)

The EEPROM is a CMOS serial I/O type memory which is capable of electrically erasing and writing 1,024 bits.

The EEPROM contains menu data.

The following shows the memory access operation.

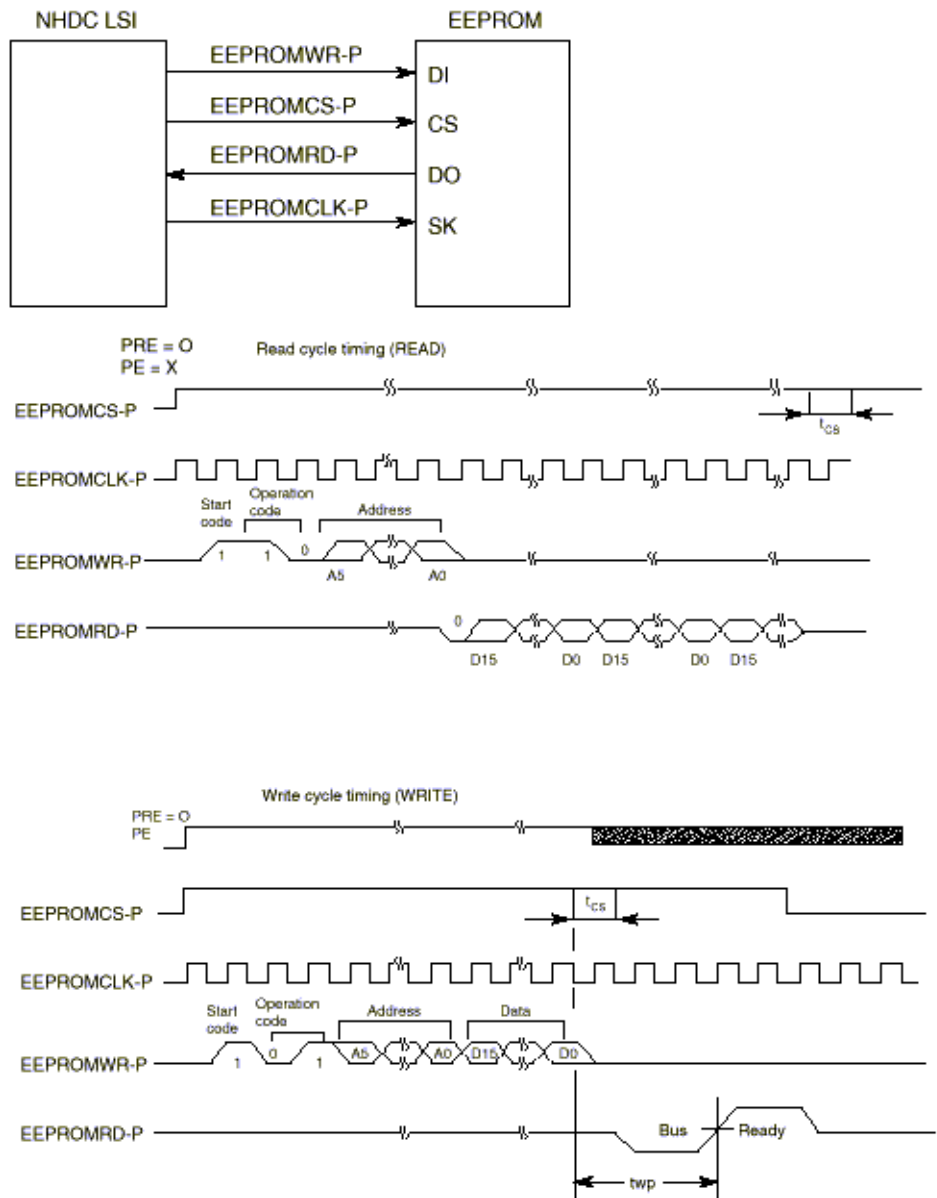

Figure 2.5

(6) Main LSI (IC38: MSM91U036)

MSM91U036 is control LSI for head data, DC motor and modification of print data, which has the following functions.

(a) Head data control

It distributes print data stored in the DRAM over wire arrangements of the print head and outputs it as dot data in synchronism with print timing. In this time, the distribution complies with each print mode which is specified by the MPU.

(b) Print timing control

It outputs the signals which control the print timing of ODD and EVEN pins on the print head.

(c) Space motor speed control function

It controls the space motor with micro-programs to accelerate/decelerate it. This LSI also controls the speed of the space motor in agreement with each print mode.

(d) I/O port

This printer has 8-bit output port which is used for controlling the SRAM.

(e) Head position count

It counts the outputs from slit sensors (SPPHASE A, B) located on the space motor to keep monitoring the current position of the print head.

(f) Print data modifying function

It modifies the print data stored in the DRAM with command inputs from the MPU.

(g) DMA control function

It outputs a DMA request to the MPU, simultaneously controlling the DMA.

This LSI is connected in multiplex to the MPU.

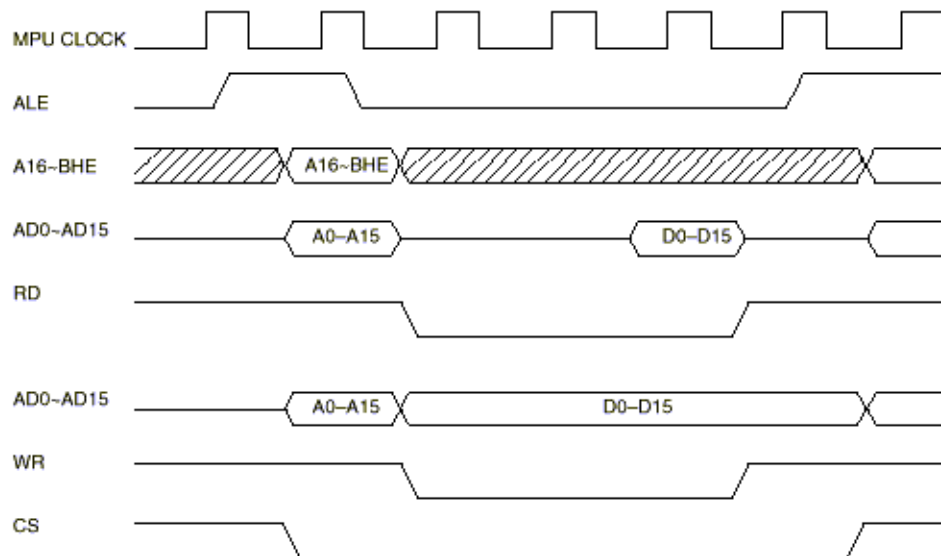
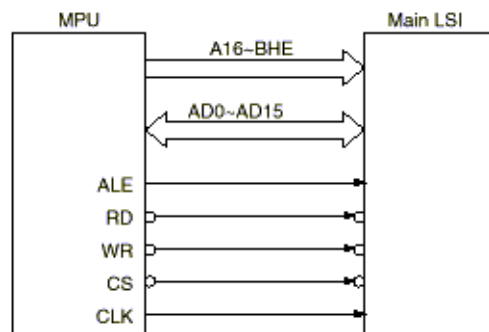

(7) NHDC LSI(IC27: TC190G08CF-7036)

This LSI controls timer, interruption, memories, printing, external interface, motor drive interface.

(a) Timer control

It controls the watchdog timer for detecting any out-of-control program, baud rate generator for setting the baud rate of the serial interface, and pulse generation timer for AG plus count.

(b) Interruption control

It controls LSI inside interruptions, external interruptions and interruptions from an external interface as outputs for the MPU.

(c) Memory control

DRAM and SRAM control, chip select output control of ROM, flash memory and MUPIS, and bank switch control for expanding their memory spaces.

(d) Print control

It creates a print timing corresponding to the print DPI to control the position and print correction for pins. This also controls the print Mask and DMAC which reads print data from the memory and transmits it to the print output buffer.

(e) External interface

It controls various interfaces for main LSI, IEEE1284, serial, MUPIS, OpePanelLSI, EEPROM.

(f) Motor drive interface

Each control of OVDV pulse generation for AG motor, generation of pulse for switching ribbon motor phase, and OVDV pulse generation for LF motor.

(8) Sub LSI (IC17, IC18: MSM72V017)

This LSI is the I/O port LSI which controls the input/output of various controlling signals with command inputs from the MPU.

(a) Sub LSI #1 (IC17: MSM72V017)

Input/output control for controlling signals to various sensors, FAN controlling signals, sensor slice level controlling signals, AG motor controlling signals, and LF motor controlling signals.

(b) Sub LSI #2 (IC18: MSM72V017)

Input/output control for controlling signals to various sensors, SP motor current controlling signals, external interface controlling signals, TR motor controlling signals, bail motor controlling signals, cutter motor (for optional connection) controlling signals.

(9) Serial I/F LSI (IC35: 85L30)

This LSI is the serial I/F LSI which controls the input/output of serial I/F controlling signals with command inputs from the MPU.

2.1.3 Initialization

This printer is initialized when the power is turned on or when the I-PRIME-N signal is input from the host side via the parallel interface.

For the initialize operation, the RESET-N signal is first output from the reset circuit to reset the MPU and LSIs. When resetting ends, the program starts and the LSIs are reset by NHDC LSI via LRESET-N. Reset operation by I-PRIME starts program to initialize, but does not reset the MPU. The program here sets the mode of the LSI including the MPU, checks the memories (ROMs and RAMs), then carries out carriage homing, and determines the LF motor phase.

Finally, the program establishes the interface signals (P-I/F: ACK-P signal sending, and S-I/F: BUSY-N signal off) and lights the SELECT lamp to inform the ready state for receiving to the host side and ends the initialize operation.

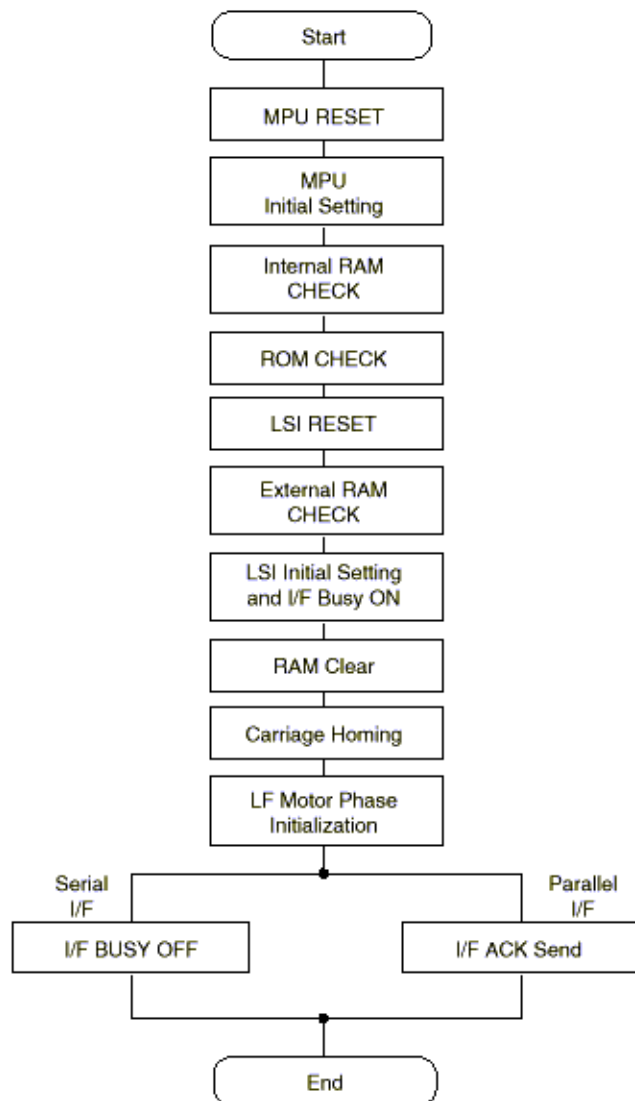

Figure 2.7

Copyright 1998, Okidata, Division of OKI America, Inc. All rights reserved. See the OKIDATA Business Partner Exchange (BPX) for any updates to this material. (<http://bpx.okidata.com>)



Service Guide for PM4410

Chapter 2 Operation

2.1.4 Interface Control

The PM4410 is provided with the centronics parallel interface and RS-232C serial interface as standard features. Also it can be connected to option OKI HSP or Opt. Card. The interface cable can be connected simultaneously with these interfaces.

These interfaces can be switched with the menu switch on the operation panel, in addition, you can designate auto-select for them. The MPU communicates with hosts through the NHDC according to the selected interface mode. The selected interface is stored to the EEPROM and can maintain even after powering the printer off.

Copyright 1998, Okidata, Division of OKI America, Inc. All rights reserved. See the OKIDATA Business Partner Exchange (BPX) for any updates to this material. (<http://bpx.okidata.com>)

2.1.5 Parallel Interface Control

The Parallel data input from the host to the NHDC LSI is latched to its internal register at the falling or rising edge of the STROBE-N signal.

At the same time, the LSI sets the BUSY signal to the high level to inform the host that the data is being processed, and outputs the INT-P signal to inform the MPU of data reception. The data is read upon receiving the RD-N signal from the MPU.

When the data processing ends, the BUSY signal is set to off and the ACK-N signal is sent to request the next data. When reception is impossible because the buffer is full, the BUSY signal is sent to request stopping of data transmission.

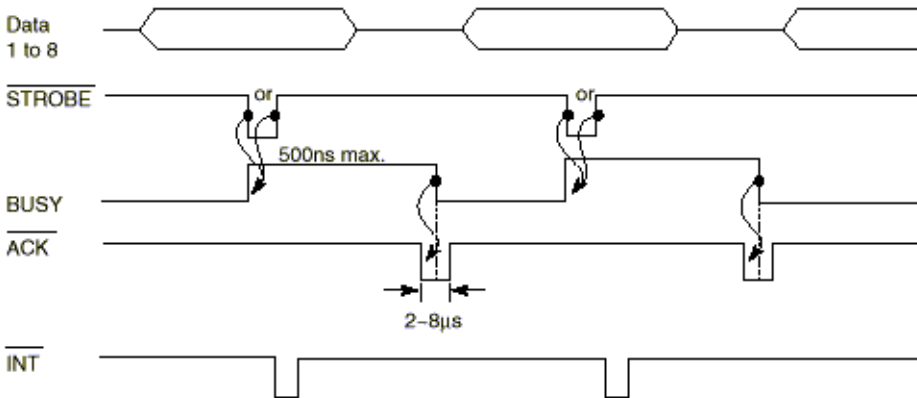
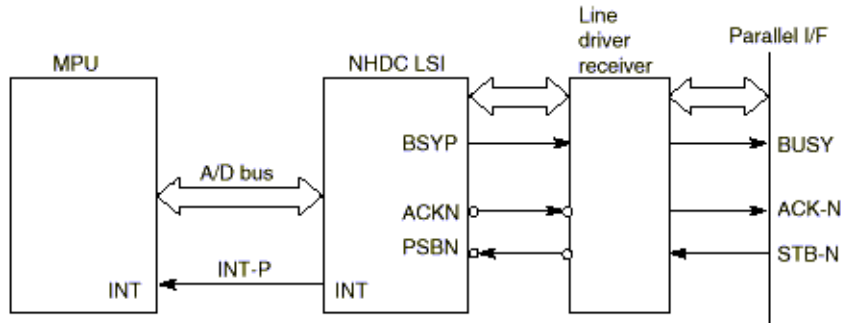

Figure 2.8

2.1.6 Serial Interface

The MPU sets the baud rate which is selected with the menu switch for the NHDC LSI and have the serial I/F LSI to output the clock frequency of the baud rate.

Input signals from the serial I/F (DSR, CTS, CD and RD) are converted into TTL level ones by the Line driver/receiver and input to the serial I/F LSI and NHDC LSI. The serial I/F LSI converts serial data into parallel data to output it to the MPU.

Output signals (DTR, RTS, SSD and TD) to the serial I/F are output from the MPU to the NHDC LSI and serial I/F LSI, and then converted through the Line driver/receiver into line voltage which is output to the serial I/F.

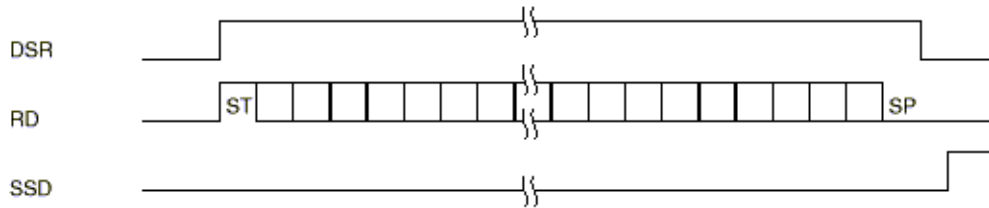
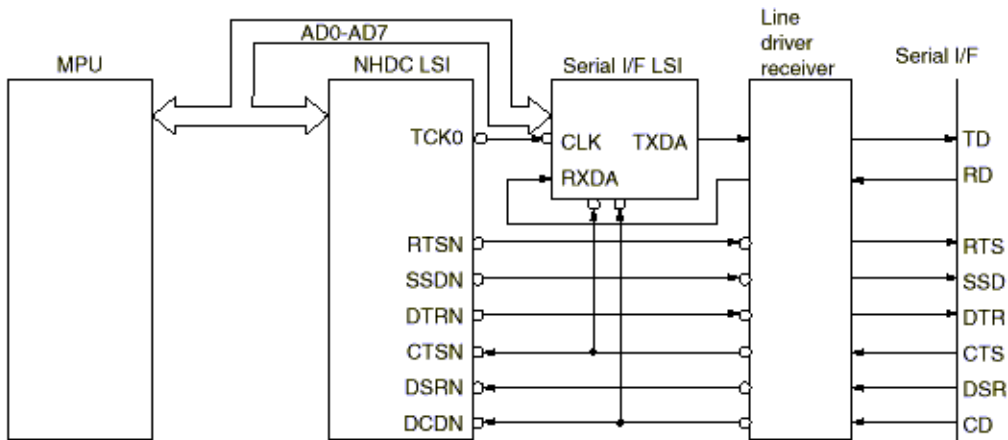

2.1.7 Printing Operation

The time chart for the spacing and printing, line feed operations are as shown below.

The spacing, printing and line feed operations are controlled by the MPU. The MPU also controls the entire timing of these operations.

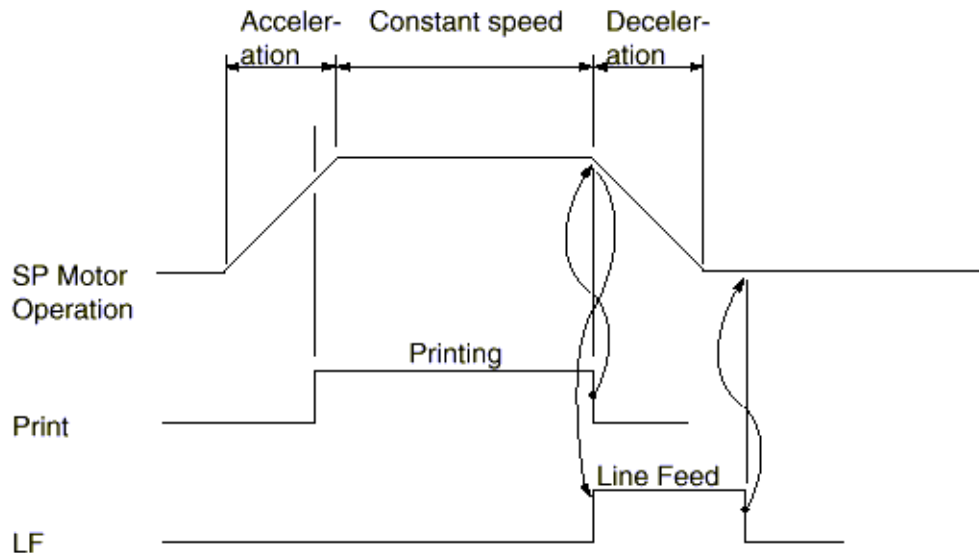

Figure 2.10

When starting the printing operation, the MPU specifies the distance moved, print start position, printing speed, etc. to the LSI, and activates the spacing motor. The MPU, when the carriage arrives at the print position specified, activates the printer to start printing, and when printing terminates, the MPU activates the line feed motor for line feed operation. During the line feed operation, the MPU causes the carriage to decelerate. Upon termination of line feed operation, the spacing operation is performed.

2.1.8 Printhead control

The printhead is controlled by the Main LSI and NHDC LSI.

Printing is synchronized with the ITOOUT signal from the NHDC LSI.

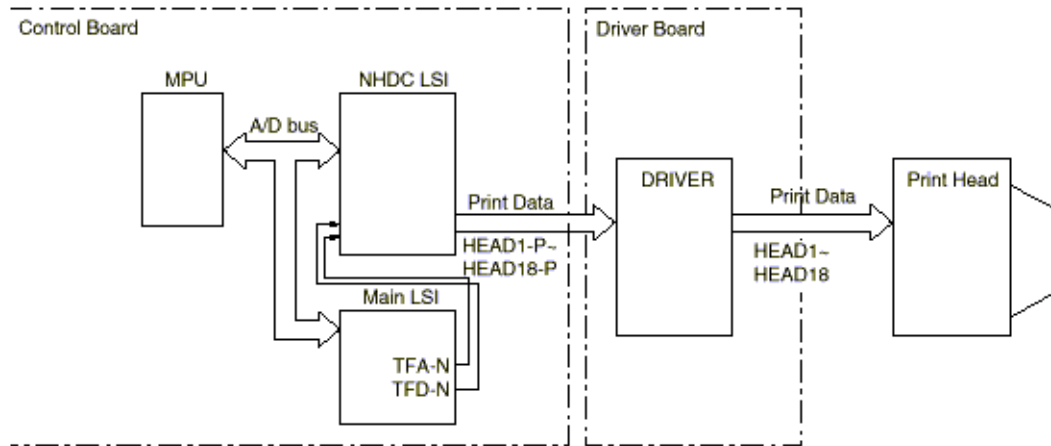

Figure 2.11

The NHDC LSI outputs the dot timing1 signals (DT1:1~18) and the dot timing2 signals (DT2:1~18), and the driver IC drives each dot magnet. These signals are output from the NHDC LSI after the following corrections for final driving time determination inside the LSI:

- (1) Correction for the number of pins driven
The driving time is corrected according to the number of pins driven at the same time out of 18 pins.
- (2) Correction according to adjacent pin drive timing
The driving time is adjusted by checking whether the pin adjacent to the pin to be driven is driven on the previous timing.
- (3) Correction for head gap
The driving time is corrected according to the head gap.

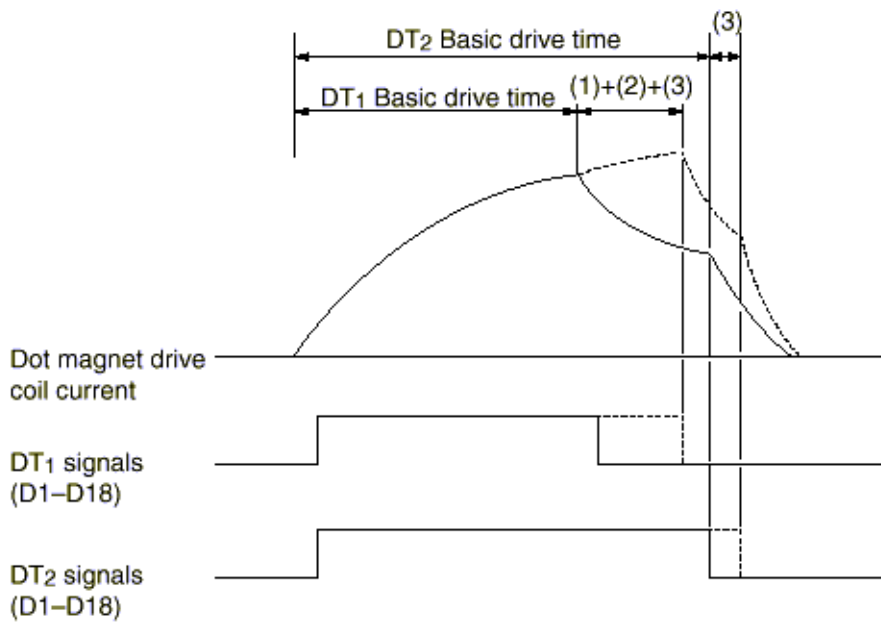

Figure 2.12



Service Guide for PM4410

Chapter 2 Operation

2.1.9 Print Compensation Control

The print compensation can be made as shown below:

(a) Simultaneous Compensation of the number of impact pins

The NHDC LSI is provided with the compensation table for each pin to make necessary compensation.

Number of impact pins	Few ↔ Many
Drive time	Short ↔ Long

(b) Duty control

1. If the number of the lines which exceeds 60% printing duty is continuous 8 lines, the printer starts 2-path printing at the 8th line.

2. If the printer can activate 12 pins simultaneously in a line, it 2-path prints the line.

(c) Temperature compensation (See 2.1.14 "Alarm Circuit").

(d) Print mode compensation

According to the thickness of the printing medium, the print mode is compensated as shown in the table below:

Head Gap Range	1	2	3	4	5
Print speed	100%	97%	95%	90%	89%
Drive time		Short	↔		Long

(Drive time lengthens at each step.)

2.1.10 Space motor control

(1) The Main LSI generates the SPDV-P signal upon receiving the spacing command from the MPU. This is a fixed cycle pulse signal.

The Main LSI varies the pulse duty according to the speed data from the MPU to control the motor speed.

The SPFOW-P or SPREV-P signal from the Main LSI changes the current direction in the DC motor to run the motor in the forward or reverse direction.

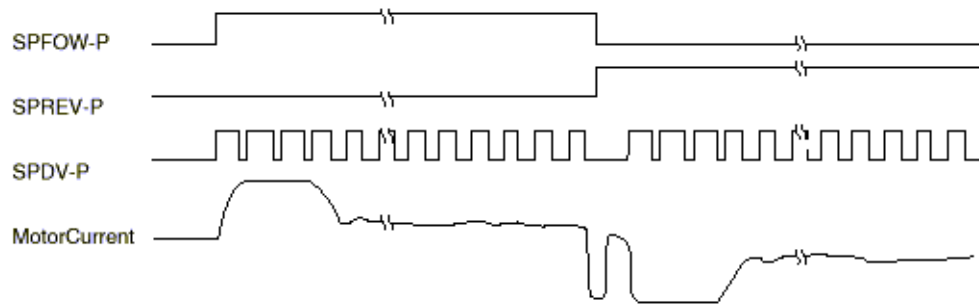

Figure 2.13

(2) Slit encoder

As the space motor rotates, it generates feedback pulse signals SPA-P and SPB-P. The Main LSI detects the edge pulses from these signals and multiplies the frequency to output the S720-P signals as the normalized timing to NHDC LSI to generate head drive timing.

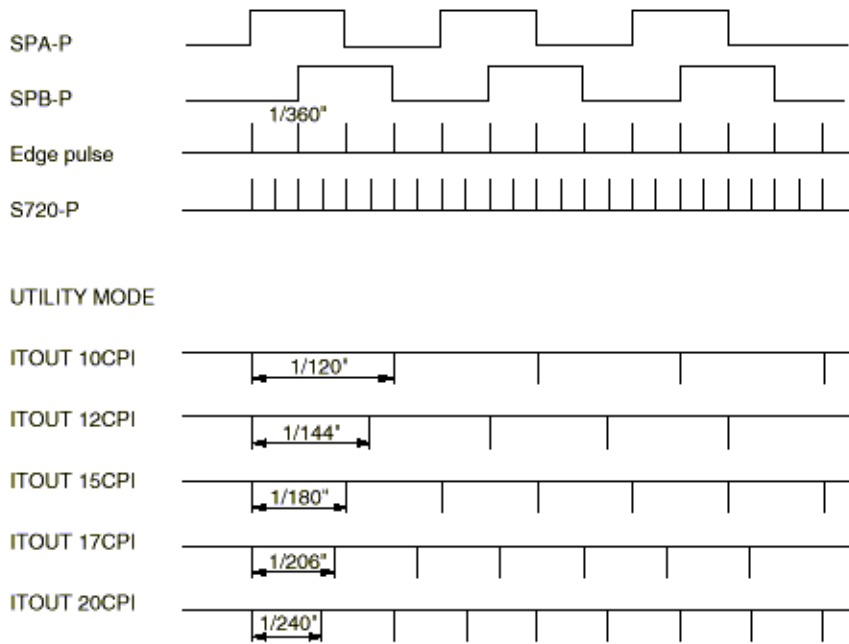

Figure 2.14

2.1.11 Line feed

The LF motor is locked by the current supplied from +12V according to the pulse duty of the LFCHOP-P signal during the stop period.

It is driven by +44V application by the LFOVDV-P signal for line feed operation.

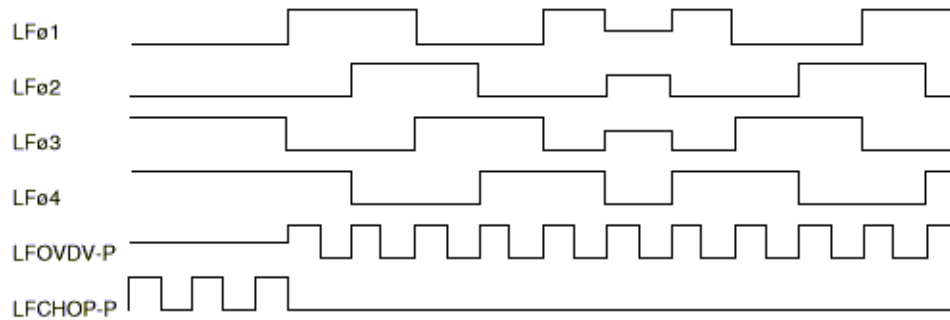

Figure 2.15

2.1.12 Bail, tractor, switching, AG, ribbon motor control

Bail, tractor switching, AG and ribbon motor control is as shown below. The AG motor is locked with AGHOLD-P.

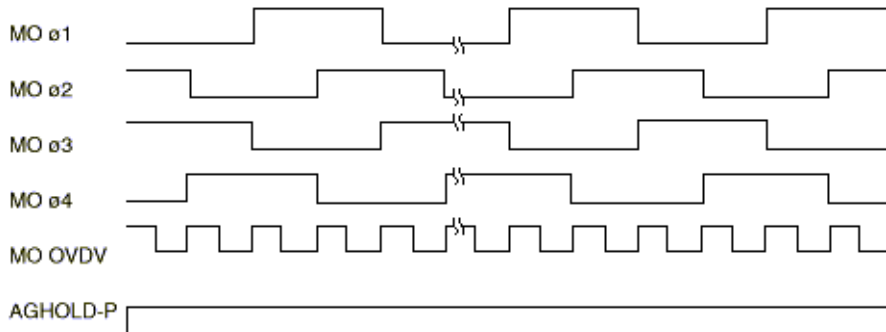

Figure 2.16

2.1.13 Operation Panel

The clock synchronization OPCLK of NHDC LSI is used to input the switch data and output the LED data and LCD data through the operation panel control LSI (IC1: BU6152S).

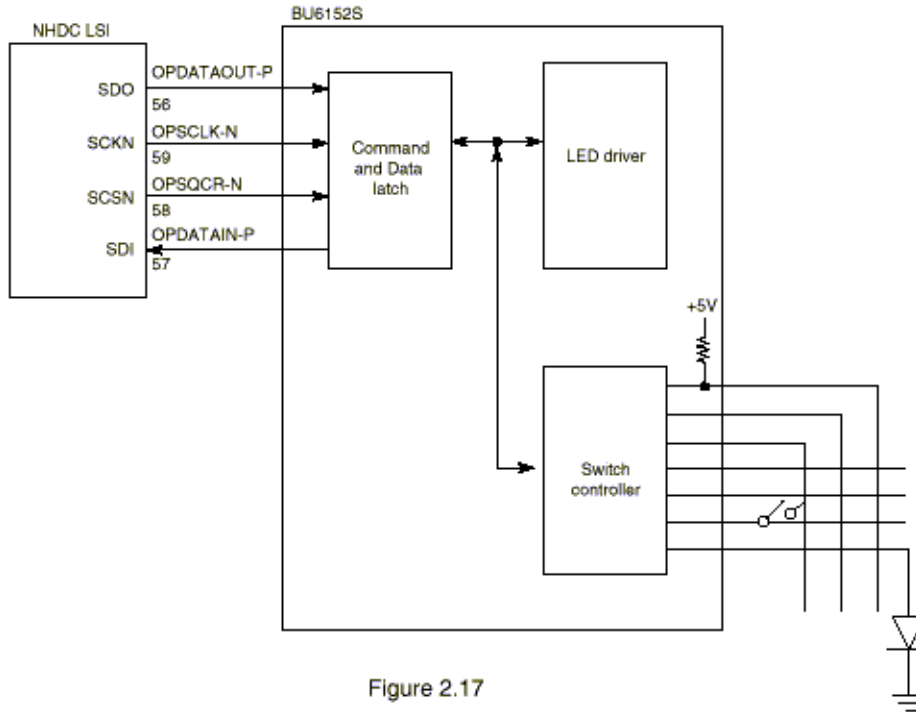

Figure 2.17

A 2-byte (15 bits + 1 even parity bit) command (OPDATAOUT-P) is transmitted to the LSI (BU6152S) in synchronization with the OPCLK-N signal. The LSI decodes this command and when it is found to be legal, returns a 2-byte command response back to the NHDC LSI which includes data on Switch information, LED status, LCD status receive command ACK/NAK and 1 odd parity bit.

Any transmission errors found cause the command to be reissued after the transmission of the OPSQCR-N signal.

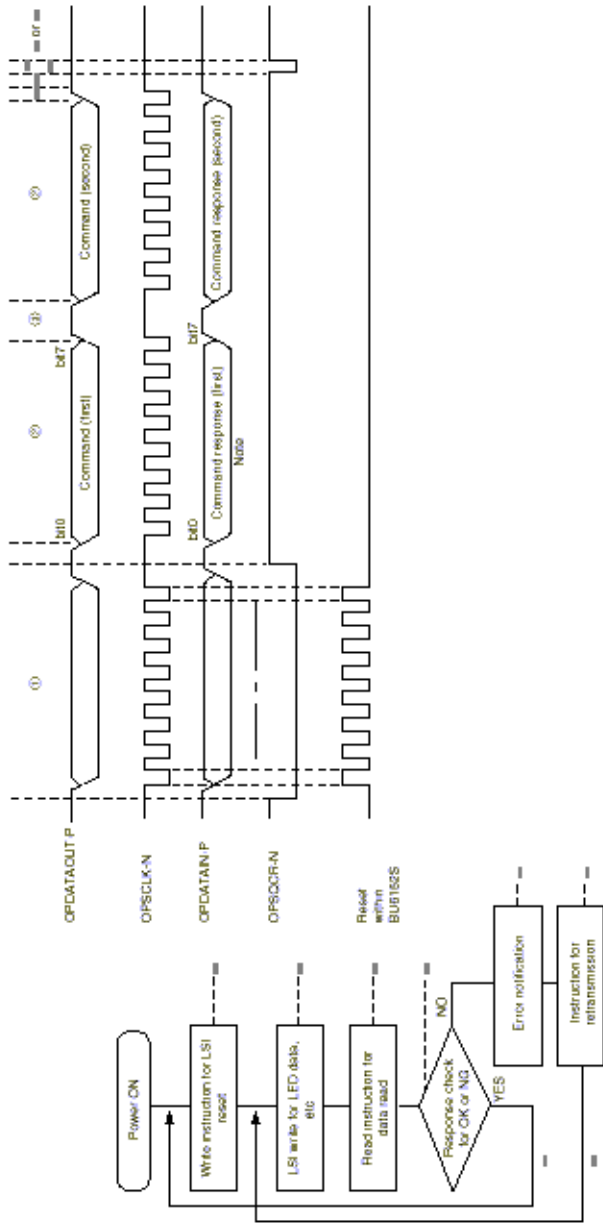

Figure 2.18

Note: From the illustration above, you can see that the command and the command response are output at the same time. This is because the bit 0 to bit 3 of OPDATAIN-P are fixed so that the response can be returned before decoding the command.

Service Guide for PM4410

Chapter 2 Operation

2.1.14 Alarm circuit

(1) Driver circuit abnormality detection alarm.

This protective circuit prevents secondary troubles by stopping the power supply upon detection of an abnormality in the print head, SP motor driver circuit or other motor driver circuits.

This circuit monitors the driving time by means of the signals (DT1COM1, SPV, LF COM, AG-MCOM, RBN-MCOM, TR-MCOM, BEIL-MCOM and RENCOM) connected to the overdrive signals for each driver circuit. If any driver circuit driving time exceeds the specified time, the POWOFF-P signal is output to switch off the power supply to stop all DC voltage outputs.

(2) Head high temperature alarm circuit

The thermistor built in the head monitors the head temperature for head coil protection. If high duty printing continues for a long time, the head temperature rises. If it reaches a certain level (approx. 148 °C and 158°C), head high temperature alarm 1 is detected to start one-way printing with a 40 ms interval after each line. When head temperature alarm 2 is detected to start one-way and two-pass printing with a 1.2 sec. interval after each line for the head temperature to fall. When the temperature falls to below the detection temperature, normal printing operation restarts.

As the head temperature rises, the resistance of the thermistor decreases and the potential of the input to the comparator in the head thermistor alarm circuit rises, when the potential goes above the alarm 1 specific level, MPU goes into alarm 1 procedure, simultaneously MPU continues to check if the potential goes above alarm 2 specific level. When going below alarm 2 level, MPU goes into alarm 2 procedure.

(3) Paper end detection circuit

Five sensors (front tractor paper end sensor, rear tractor paper end sensor, sheet jam sensor, sheet top sensor and sheet width sensor) are provided for different paper set routes to monitor paper end. When paper runs out, the corresponding sensor is turned off to input the FTRPESW-P, RTRPESW-P, SHEETJAM-P, SHEETTOP-P, SHEETWITH-N signal to the sub LSI (IC17), and is read by the MPU. The MPU stops the printing operation, informs the host of the paper end and jam, and lights the alarm lamp.

(4) Cover open alarm circuit

When the front access cover is PUSH opened, the COVEROPN1SW-P signal is input to the main LSI and the NHDC LSI from the cover open microswitch, and an invalid signal is input to MPU. The MPU stops the printing operation as soon as possible, informs the host that receiving is impossible, and lights the alarm lamp.

When the front access cover is opened and, the interlock switch cuts the SP motor drive current and makes the SP motor stop.

(5) Fan alarm circuit

For each of the five fans, the FANALM-P signal is provided to detect fan rotation/stop. The signal is at Low level when the fan rotates, while it becomes High when it stops. The MPU monitors this signal level. When the High level is kept for one minute or longer, the MPU stops the printing operation, informs the host of the fan alarm, and lights the alarm lamp.

(6) Head thermistor short/open alarm circuit

The head thermistor voltage is monitored physically. When short or open circuit occurs, the HDTHALM-N signal is input to the sub LSI (IC18) and read by the MPU. The MPU stops the printing operation, informs the host of the short/open alarm, and lights the alarm lamp. When the head is unloaded, the head thermistor becomes open, resulting in this alarm.

(7) SP motor thermal alarm circuit

The voltage at the thermistor, built in the SP motor encoder block, is monitored physically. When temperature higher

than the specified level is detected, the SPTHACM-N signal is input to the sub LSI (IC18) and read by the MPU. The MPU starts printing with an approx. 0.2 sec. interval after each line to cool down the printer.

When the temperature becomes lower than the specified, normal printing will be resumed.

(8) Fuse alarm circuit

Fuses are mounted on each of the SP motor and the other pulse motors, including LF motor, where the voltage level is monitored physically. When one or both of the fuses on the main control board are blown, the FUSEALM-P signal is input to the sub LSI (IC18) and read by the MPU. The MPU stops the printing operation, informs the host of the fuse alarm, and lights the alarm lamp.

(9) Ribbon jam alarm circuit

The rotation detection knob mounted on the ribbon cassette synchronizes with ribbon rotation and detects the rotation using the sensor. The RBNSEN-P signal from this sensor is input to the sub LSI (IC17) for the MPU to monitor the rotation. With no rotation for 16 sec. or longer, the MPU stops the printing operation, informs the host of the ribbon jam, and lights the alarm lamp.

Copyright 1998, Okidata, Division of OKI America, Inc. All rights reserved. See the OKIDATA Business Partner Exchange (BPX) for any updates to this material. (<http://bpx.okidata.com>)

Service Guide for PM4410

Chapter 2 Operation

2.1.15 Power supply circuit

This switching type power supply circuit supplies the +5 VDC, ± 12 VDC and +44 VDC.

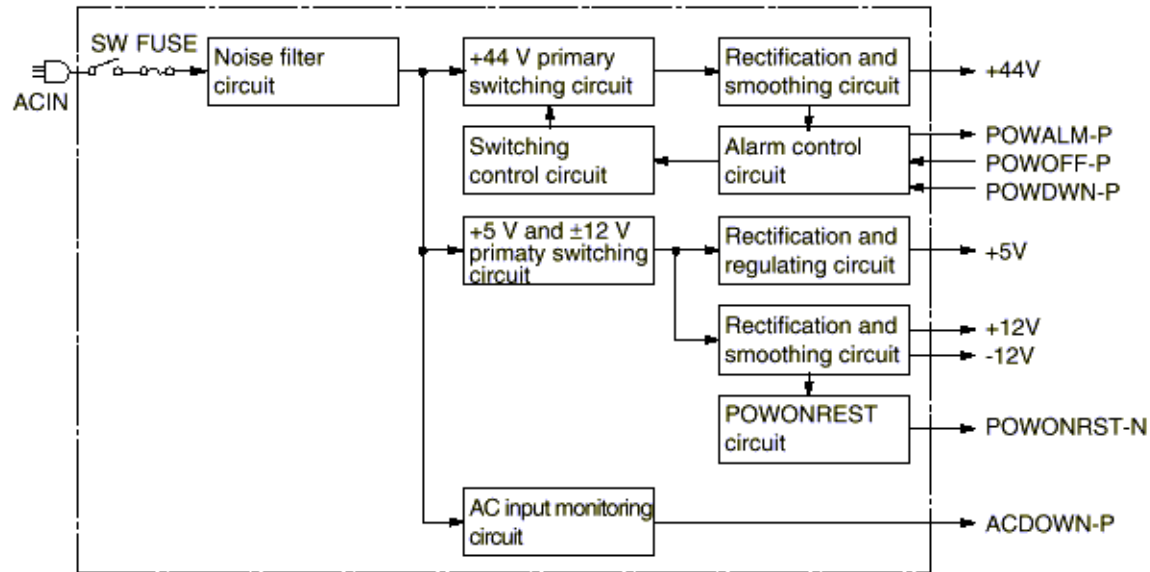

Figure 2.19

The uses of output voltages and signals are described below.

Voltage / signal	Use
+5V	Logic IC/ LED drive voltage.
+12V	Logic IC drive voltage, option interface line voltage and LF motor locking voltage.
-12V	Option interface line voltage.
+44V	Printhead, SP motor, LF motor, Other motors drive voltage.
POW ALM-P	Output from the power supply circuit upon detection of an abnormal temperature rise in the power supply circuit or an overcurrent of +44V. The control unit suppresses the overcurrent by two-pass printing. If the output does not change, the power supply circuit shuts off all DC output.
POW OFF-P	Output from the main PCB upon detection of an abnormality in the printhead, SP motor, LF motor, Other motor driver circuit, and shut all DC output off.
AC DOWN-P	Output from the power supply circuit to the main PCB upon detection of no AC input with the AC switch turned off. Then the main PCB outputs the POWOFF-P signal to the power supply circuit to have the necessary information written into EEPROM.
POW DWN-P	Output from the main PCB to the power supply circuit upon detection of no host or operator access for approx. 10 min., to start the power-save mode. In this mode, the power supply circuit cuts off 44V output.
POW ONRST-N	Output from the power supply reset circuit to the main PCB. On receiving the POWONRST-N signal, the main PCB prepares the main PCB RESET-N signal and +5VDC.

Exchange (BPX) for any updates to this material. (<http://bpx.okidata.com>)



Service Guide for PM4410 Chapter 2 Operation

Page: 22

2.2 Mechanical Operation

2.2.1 Printhead mechanism and operation

2.2.2 Spacing operation

2.2.3 Head gap adjusting

2.2.4 Ribbon drive

2.2.5 Paper Feed Mechanism

2.2.6 Bail Feed Mechanism

2.2.7 Paper End Detection Mechanism

Copyright 1998, Okidata, Division of OKI America, Inc. All rights reserved. See the OKIDATA Business Partner Exchange (BPX) for any updates to this material. (<http://bpx.okidata.com>)

2.2.1 Printhead mechanism and operation

The printhead is a spring charged 18-pin driving head using a permanent magnet. It is attached to the carriage, which moves in parallel with the platen. Electrically, this unit is connected to the control circuits through the control board.

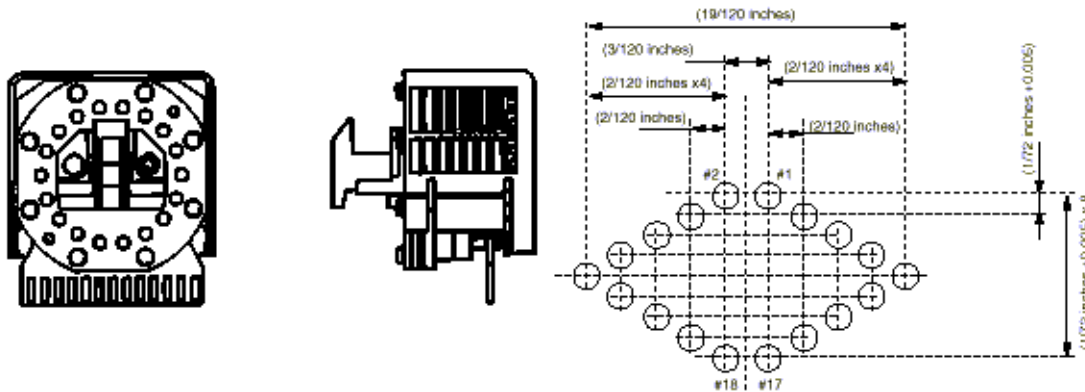

Figure 2-20 Arrangement of the head pins - View from the tip of the printhead

(1) The printhead configuration:

The printhead is composed of the following parts:

- (a) Wire guide
- (b) Armature assembly (Wire, Armature, Spring, Yoke, Spacer)
- (c) Magnet assembly (Magnet, core, coil, Yoke)
- (d) Printed circuit board

(2) Motion of Printhead (Figure. 2-14)

The armature usually loses the armature spring with a permanent magnet, making it to be attracted by the core. In this time, the print wire integrated with the armature is also in reset state, When the magnet coil is energized by a print command sent from the device controller, a magnetic flux will generate in the opposite direction against that of the permanent magnet and a restoring force of the armature in the opposite direction against the core, and then the print wire impinge on the platen. There is a paper and ink ribbon between the platen and print wire, so this impinging motion allows the ink of ink ribbon to be transferred (printed) to the paper.

(i) When printing

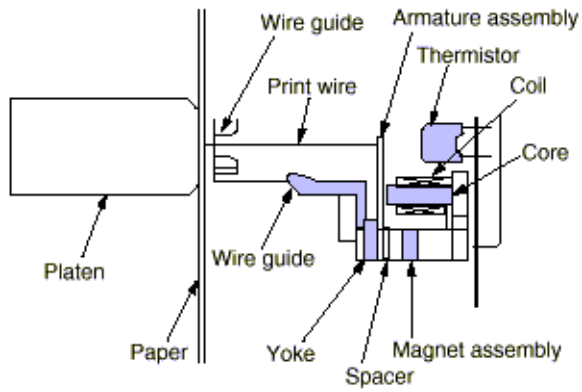

(ii) When not printing

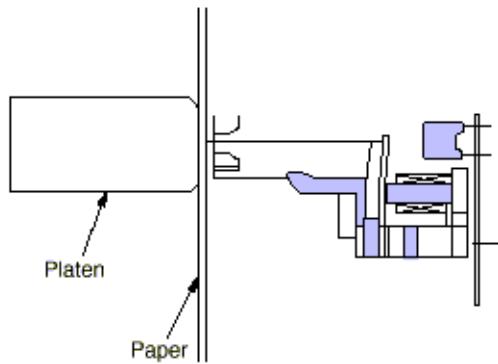

Figure 2.21



2.2.2 Spacing operation

Spacing is effected by driving the carriage assembly installed to the main shaft and slide beam set in parallel with the platen by the DC servo motor.

- (a) DC motor with motor
- (b) Carriage frame
- (c) Carriage shaft
- (d) Space belt
- (e) Sensor
- (f) Encoder disk

(1) Spacing operation

The carriage mounting the printhead moves in parallel with the platen along the main shaft and slide beam. The carriage is fixed to the mini pitch belt under the carriage frame.

When the DC servo motor runs clockwise as viewed from its front side, the driving force is transmitted to the mini pitch belt and the carriage moves from the left to the right. The DC servo motor rotating angle and speed are controlled by the count of $\varnothing A$ and $\varnothing B$ signals (with a phase difference of about 90°) from the encoder and the time intervals of the signals. The rotating direction is determined by the sign (positive or negative) of the phase difference between $\varnothing A$ and $\varnothing B$.

The mechanism is designed so that the carriage moves 2.22 inches (56.44 mm) when the DC servo motor makes one revolution.

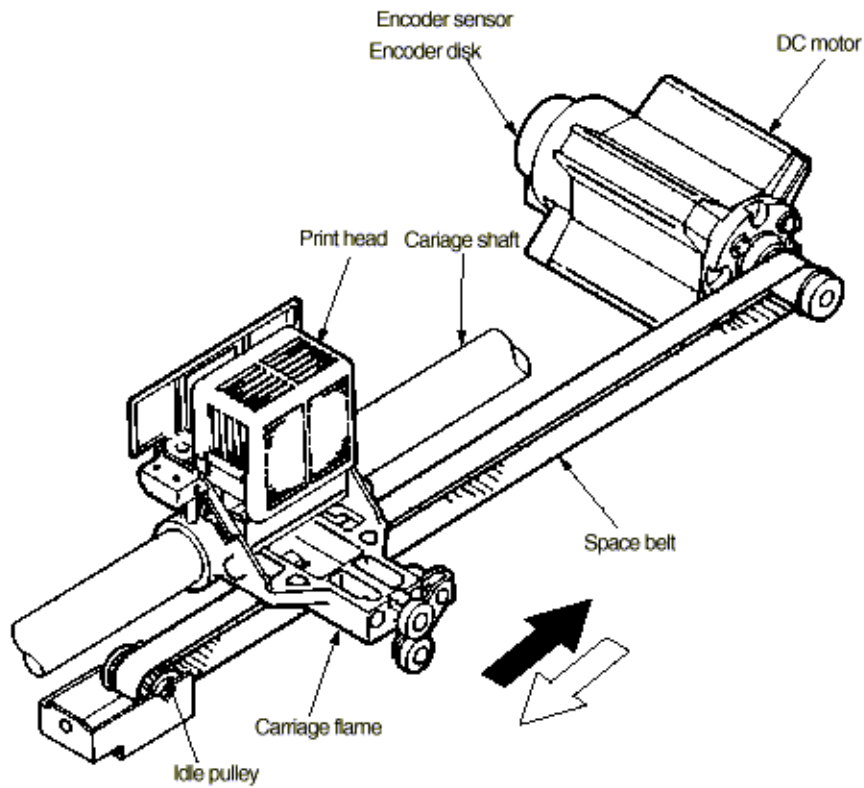

Figure 2.22

Copyright 1998, Okidata, Division of OKI America, Inc. All rights reserved. See the OKIDATA Business Partner Exchange (BPX) for any updates to this material. (<http://bpx.okidata.com>)

2.2.3 Head gap adjusting

The auto gap adjusting mechanism automatically adjusts the space between the platen and print head according to the thickness of papers. This mechanism does this driving the platen back and forth with the AG motor (pulse motor), and effects the auto gap motion after the reverse motion of the platen. The platen is reversed at power on or off line when cover open or paper end is detected, and the auto gap adjusting motion is performed when the printer returns to on line. When the printer is shifted to off line at power on or detection of paper end, the platen reverses to the position that the space to the print head becomes wider than the thickness of paper (gap open position).

As the off line mode is released, shifted to on line after platen reverses, the AG motor drives the platen to the direction that the space between the print head and platen becomes narrower. The rotational force of the AG motor moves the platen to the print head (in the direction that the space becomes narrower) through various idle gears and adjusting cam. After that, the AG plate impinges on the paper, and the AG frame is deflected, changing the core gap of the auto gap sensor located on the AG frame. When the change of the core gap is detected, the AG motor stops rotating.

Next, the AG motor reverse-rotates only a fixed step and stops. This allows the platen move backward, obtaining an proper space with the print head.

The forward an backward motion of the platen is driven by the adjusting cam being rotated, and the platen is always pulled to the rear of the unit by the spring.

(1) AG detection mechanism

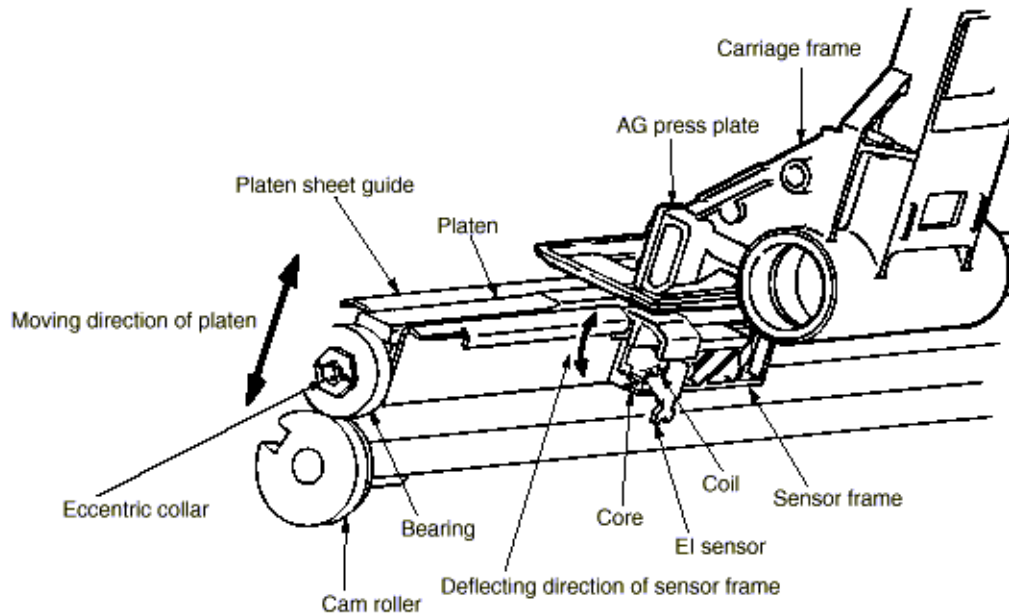
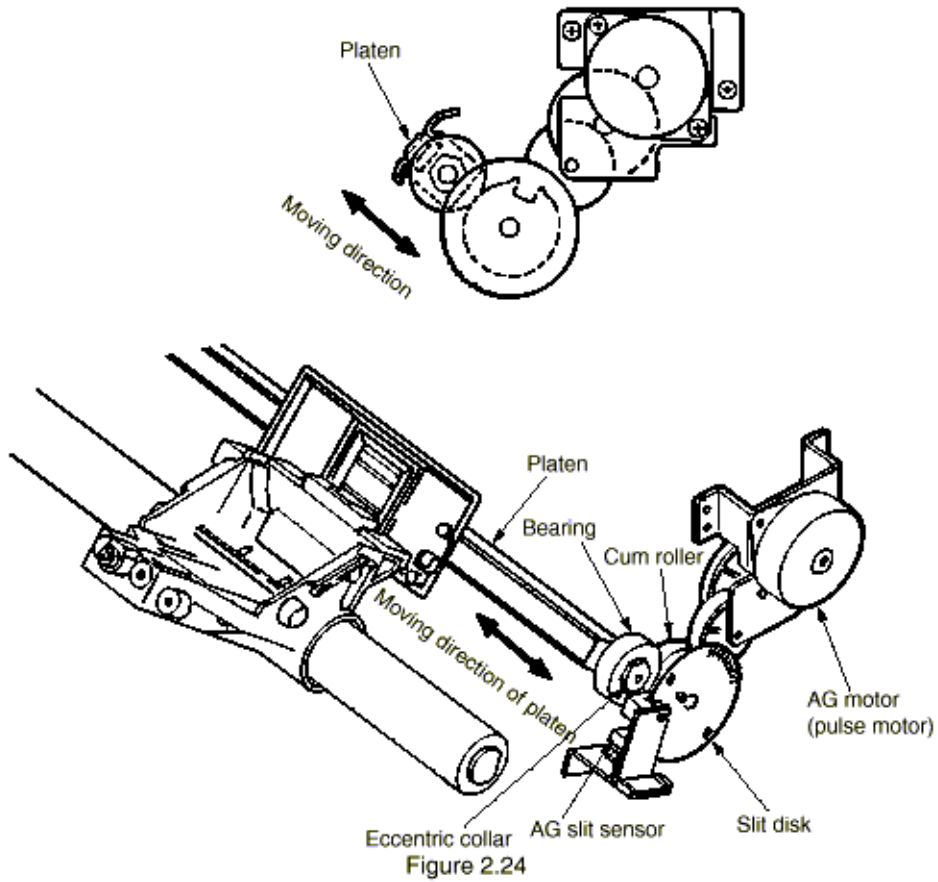

Figure 2.23

(2) AG sensor slit disk driving mechanism



(3) AG detector detail drawing

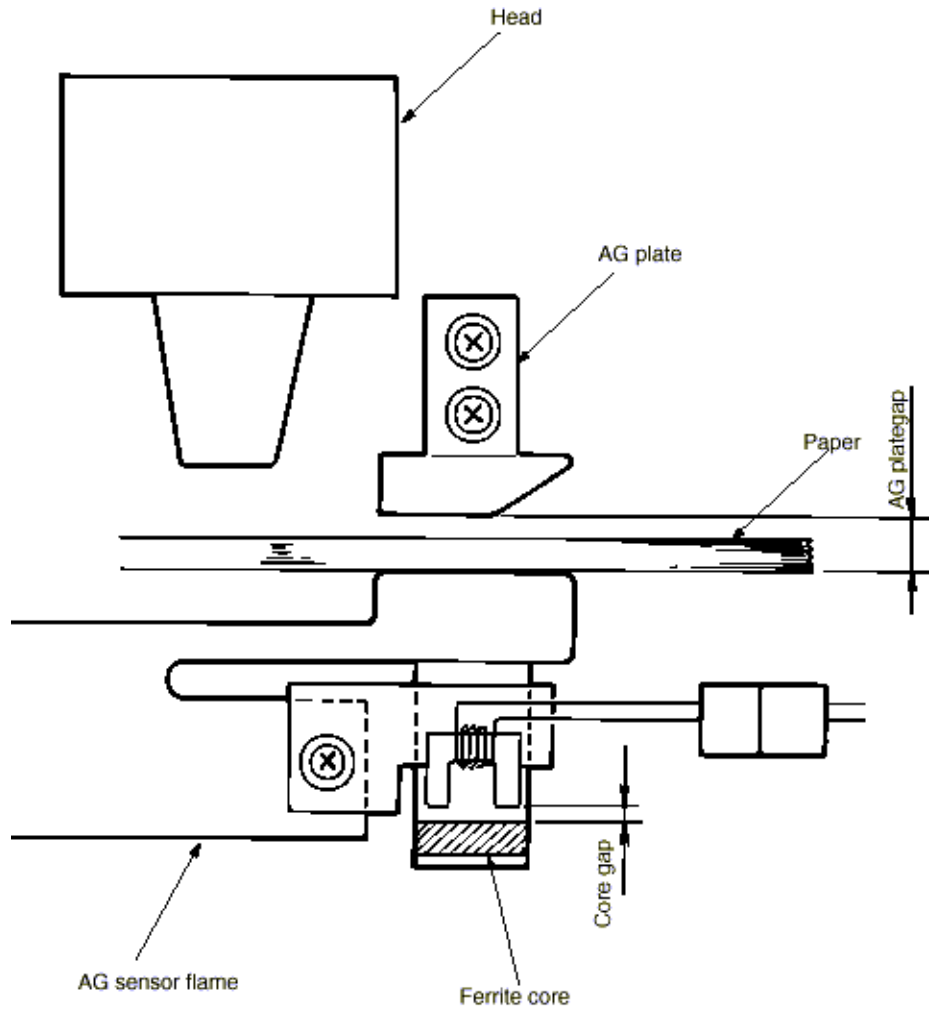

Figure 2.25

2.2.4 Ribbon drive

The ribbon feed mechanism feeds the ink ribbon and functions by driving the ribbon motor (pulse motor).

(1) Ribbon cartridge

This has a mechanism of capable of printing clear characters at all times by using a one-way-feed endless ribbon.

(2) Feeding

The ribbon feeding mechanism starts running regardless of whether the printer is printing or not, and stops at the same time when the spacing motion stops.

When the ribbon motor is driven, the rotational force is transmitted to the drive roller in the ribbon cartridge through ribbon feed gears, and the ink ribbon fed.

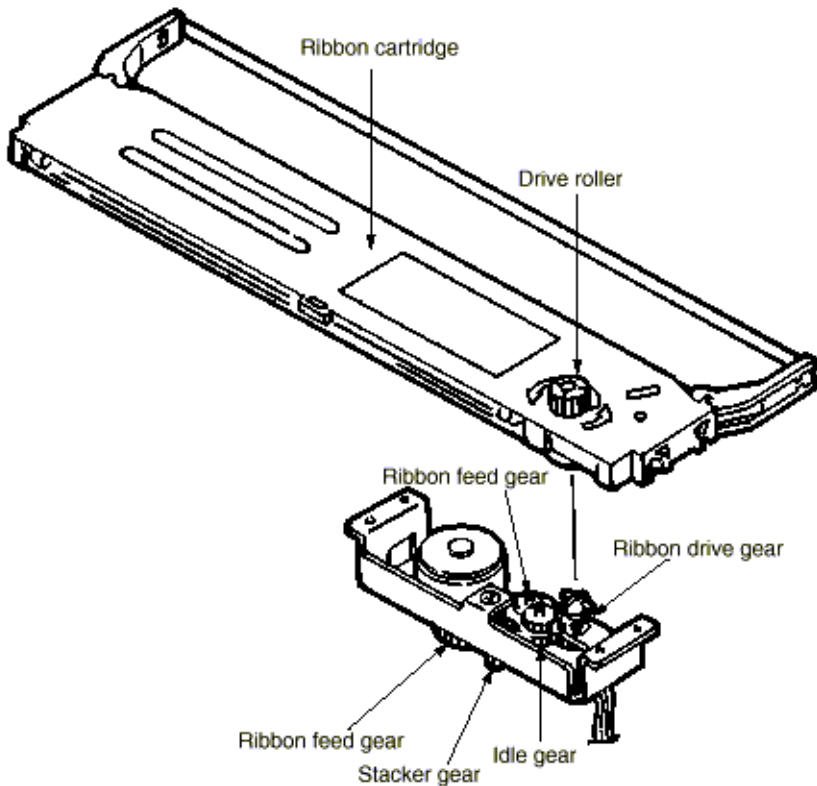

Ribbon feed mechanism

Figure 2.26

2.2.5 Paper Feed Mechanism

The line feed on the print paper is driven by the LF motor (pulse motor) and done by rotating the sheet feeder and feed roller.

(1) Front tractor

The rotation of the LF motor rotates the drive shaft through the LF gear, change gear and front tractor drive gear, driving the pin belt of the front tractor Assy. This feeds a continuous paper set on the pin belt. Simultaneously, this drives the feed roller F/R through the mini-pitch belt following LF gear to carry the in synchronization with the tractor.

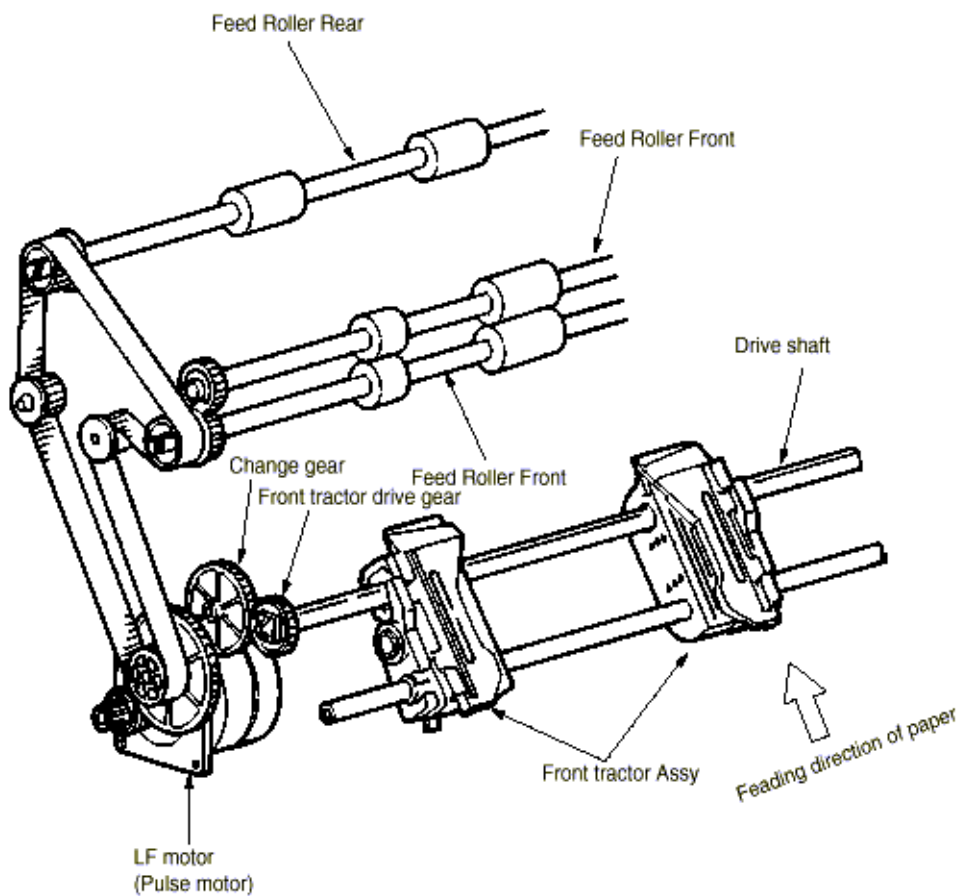

Figure 2.27

(2) Rear tractor

The rotation of the LF motor rotates 2 drive shafts through the LF gear, change gear and rear tractor drive gear A/B, driving the pin wheel and pin belt of the tractor Assy. This feeds a continuous paper set on the pin belt. Simultaneously, this drives the feed roller F/R through the mini-pitch belt following LF gear to carry the paper in synchronization with the tractor.

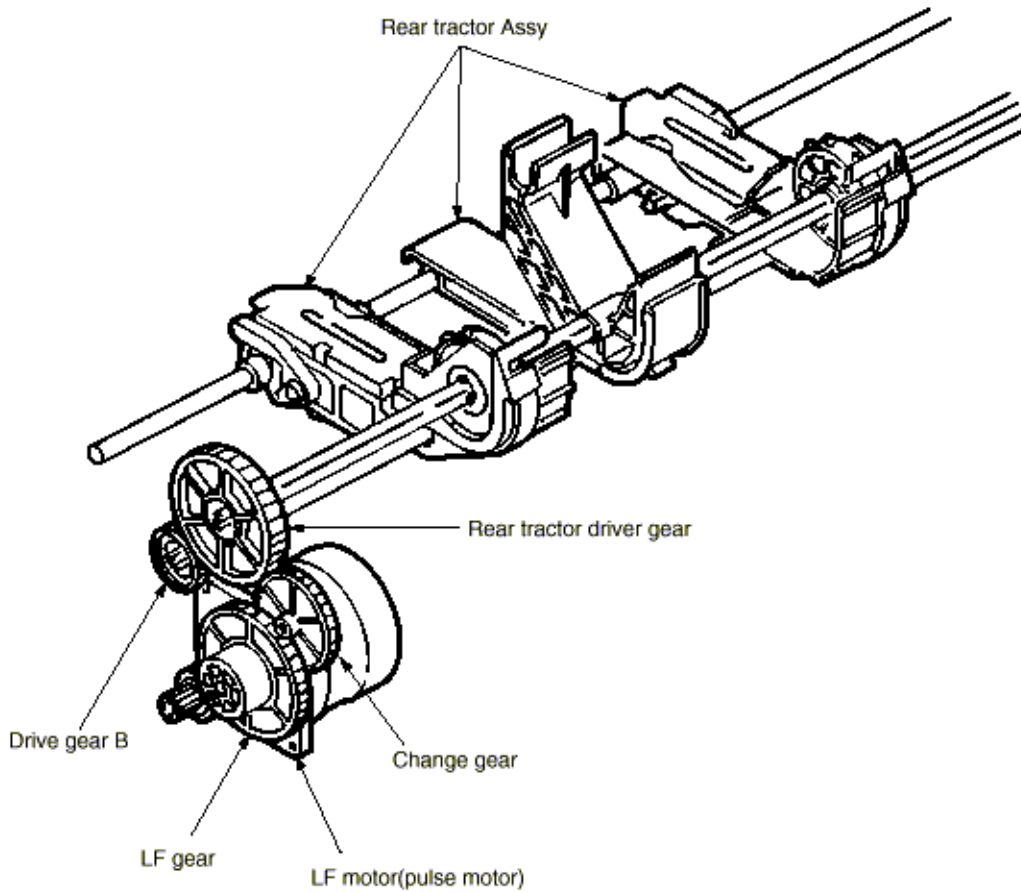

Figure 2.28

(3) Tractor changing motion

The front tractor and rear tractor are switched by exclusive tractor change motor (pulse motor).

Operating keys on the operating panel and receiving a command rotates the tractor change motor, moving the tractor change lever back and forth through gears so that the change gear moves transversely. If the change gear is shifted to right, the rotational force is transmitted to the front tractor gear, driving the front tractor. If the change gear is shifted to left, the rotational force is transmitted to the rear tractor gear A, driving the rear tractor.

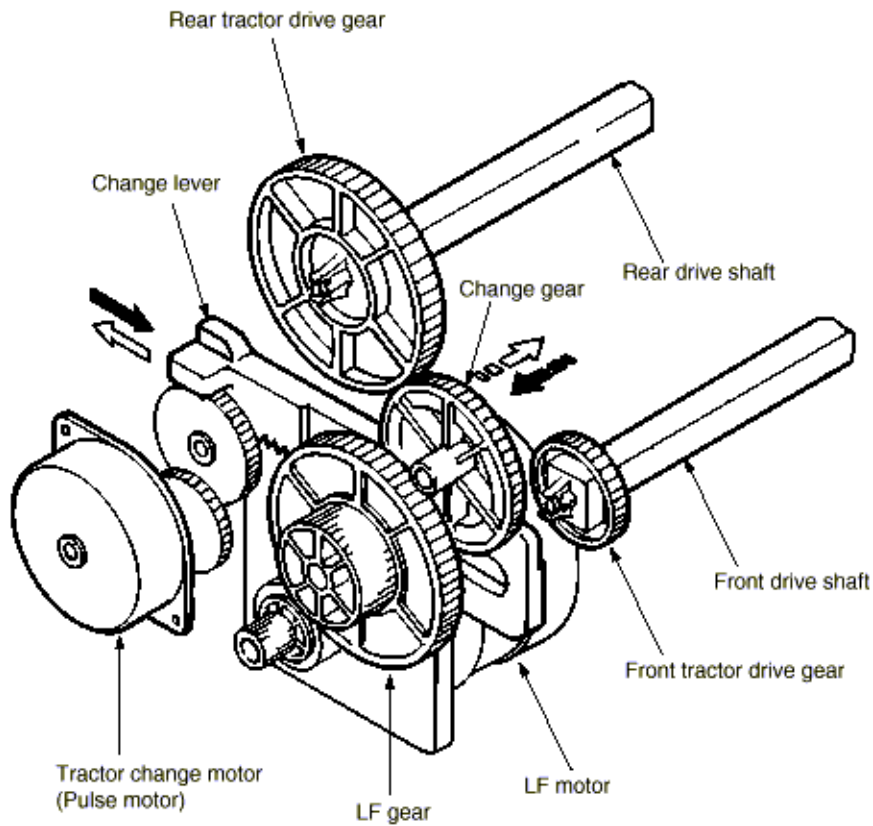
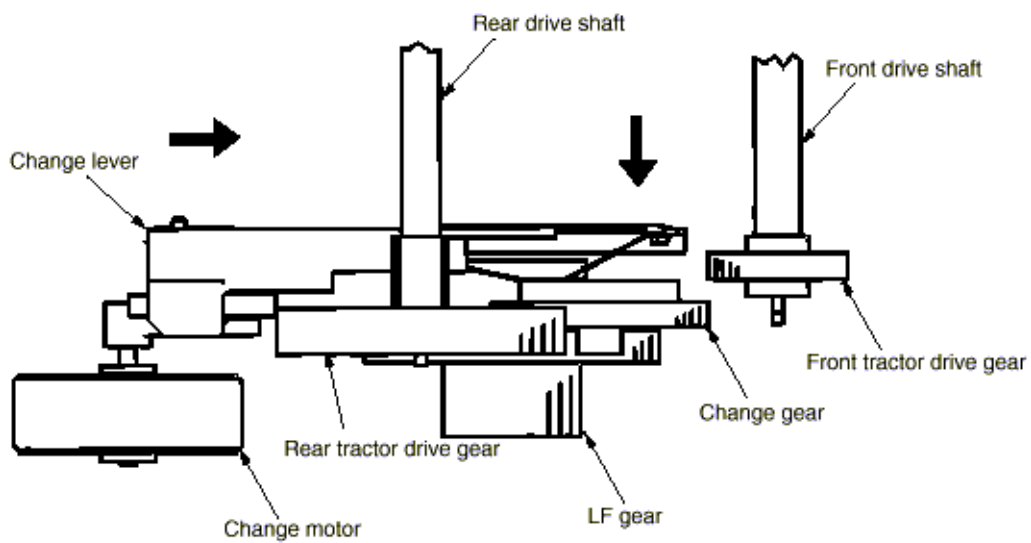
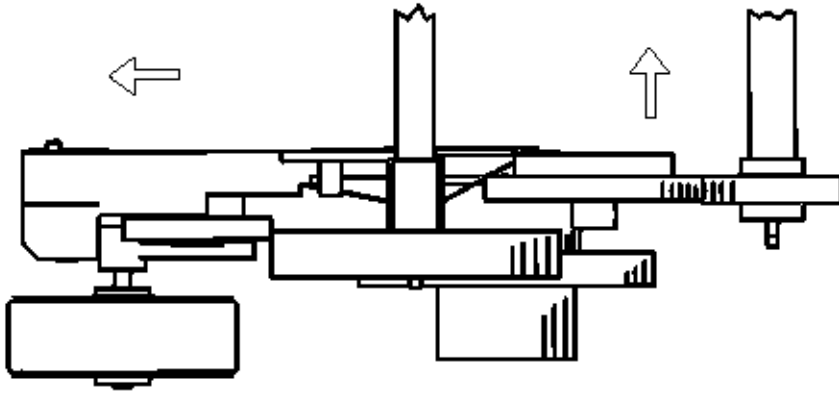

Figure 2.29

- Rear tractor drive



- Front tractor drive



Copyright 1998, Okidata, Division of OKI America, Inc. All rights reserved. See the OKIDATA Business Partner Exchange (BPX) for any updates to this material. (<http://bpx.okidata.com>)

Service Guide for PM4410

Chapter 2 Operation

2.2.6 Bail Feed Mechanism

This mechanism automatically opens the bail for pulling a paper into, and closes it after the paper passes through the bail.

This function is operated by exclusive bail motor (pulse motor). The bail motor rotates depending on the position of a paper, moving the bail lift lever (L) back and forth through gears.

The moving force of the bail lift lever (L) is also transmitted to the bail lift lever (R) through the support shaft, so the right lever moves longitudinally in synchronization with the left lever. On the bail lever, a cam plate is formed and interlocked to a pin of the bail Assy so that the bail Assy is lifted and lowered by the longitudinal motion of the bail lever.

(1) Bail close position

This position is for the condition where a paper is being printed and carried with both bail Assy and feed roller front upper closed.

(2) Bail open position

This position is for the condition where a paper is being pulled into the bail unit with the bail Assy in open position and the feed roller front upper closed.

(3) Bail half open position

This position is for the condition where a paper is parked or jammed with both bail Assy and feed roller front upper half-opened (to make removal of jammed paper easy).

The rotational force transmitted to the feed roller through mini-pitch belt following the LF gear is, furthermore, transmitted to the bail roller, allowing both-side drive of paper at the bail unit.

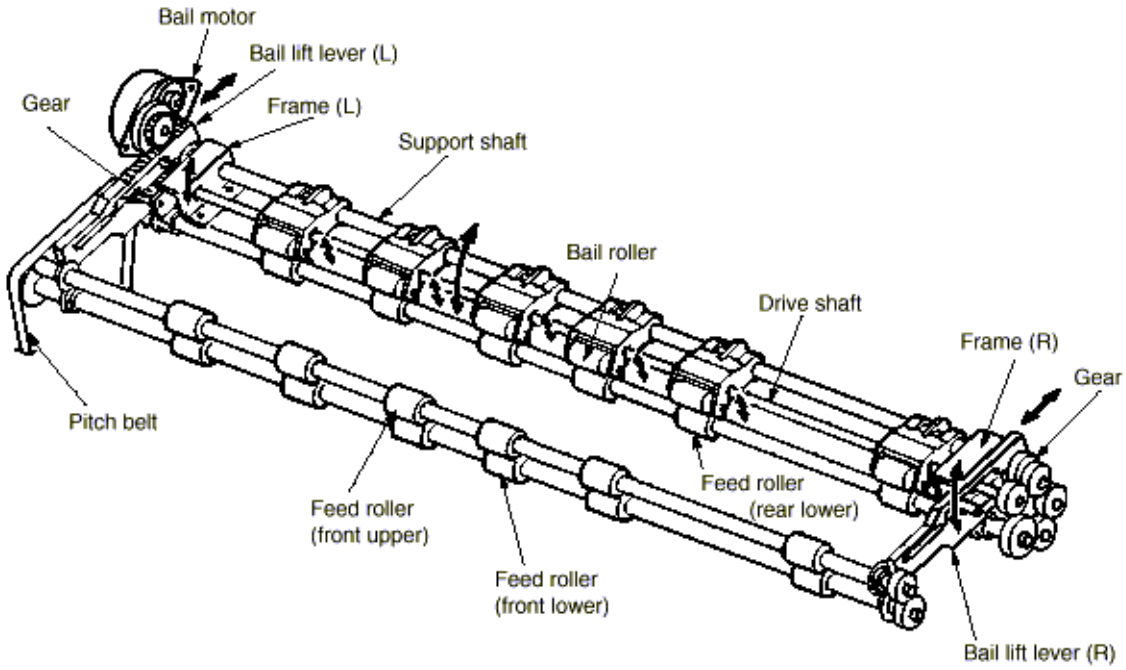
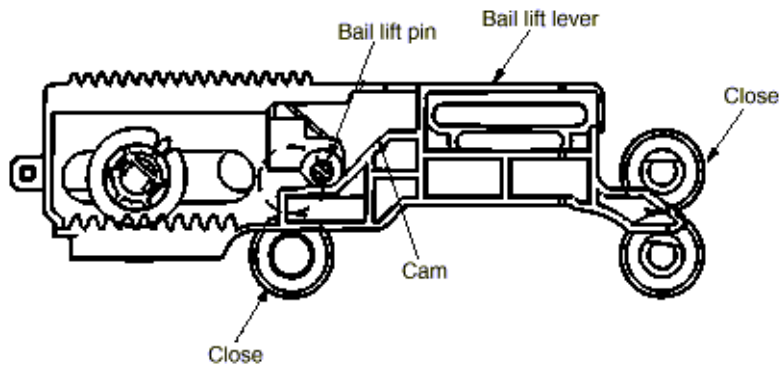
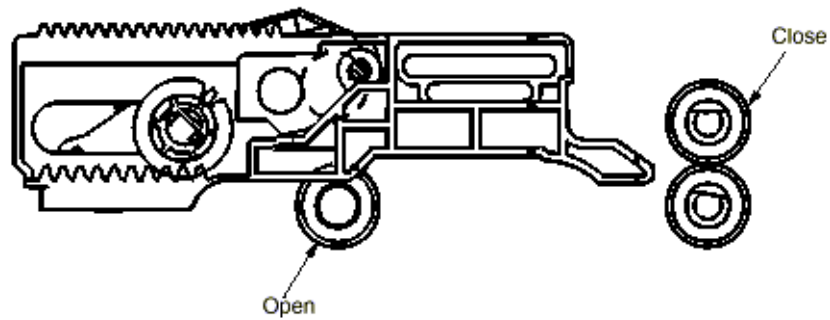

Figure 2.31

(i) Close position



(ii) Open position



(iii) Half open position

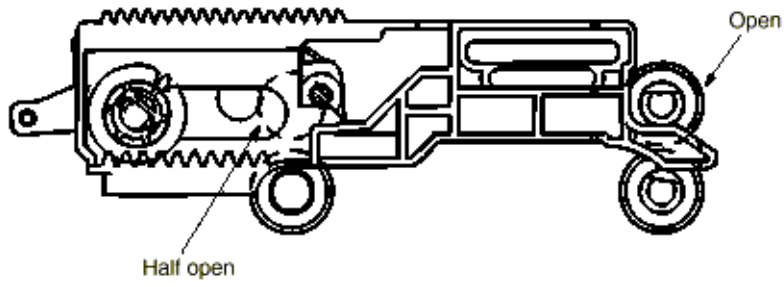

Figure 2.32

Copyright 1998, Okidata, Division of OKI America, Inc. All rights reserved. See the OKIDATA Business Partner Exchange (BPX) for any updates to this material. (<http://bpx.okidata.com>)

2.2.7 Paper End Detection Mechanism

(1) Front/ Rear form end detection mechanism (when the form with sprocket holes is used)

The form prevents the paper end lever tip end from coming into the hole on the sheet feeder cover rib and the microswitch is set to the ON state. When the form runs out, the paper end lever comes into the hole on the sheet feeder cover rib and the bottom of the paper end lever leaves the microswitch to turn it off for form end detection. Both front and rear tractor detects the paper end at 12.7mm.

(2) Front tractor

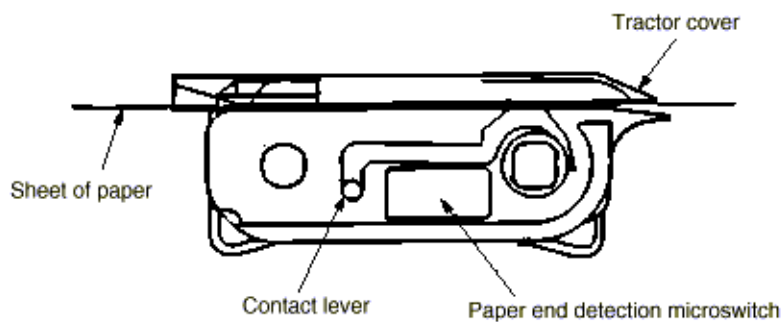

Tractor with a paper

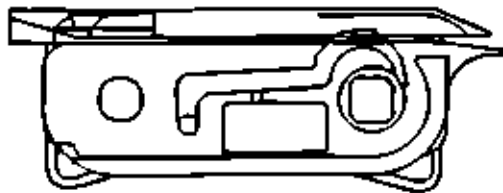

Tractor without paper

Figure 2.33 Paper end detection mechanism (front tractor)

(3) Rear tractor

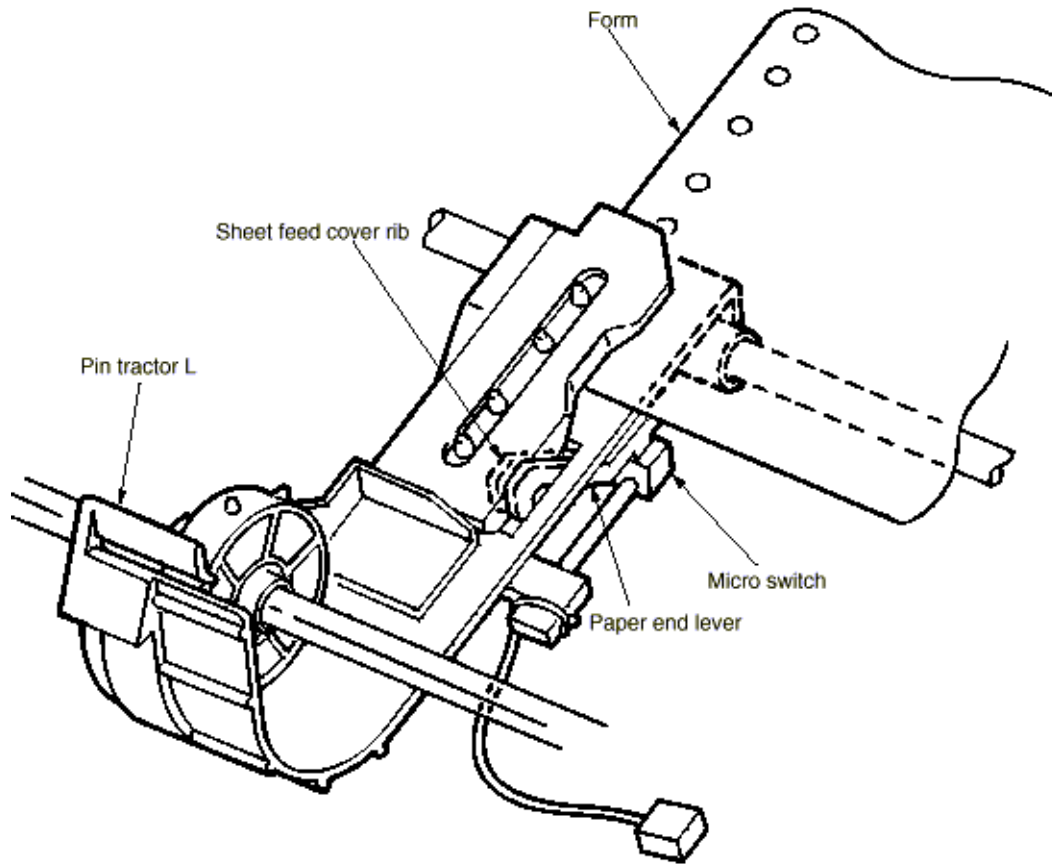

Figure 2.34 Rear form end detection mechanism

Copyright 1998, Okidata, Division of OKI America, Inc. All rights reserved. See the OKIDATA Business Partner Exchange (BPX) for any updates to this material. (<http://bpx.okidata.com>)

3.1 Precautions for Parts Replacement

The section explains the procedures for replacement of parts, assemblies, and units in the field. Only the removal procedures are explained here. Reverse the procedure for the installation.

(1) Before starting parts replacement, remove the AC cable and interface cable.

(a) Remove the AC cable and the interface cable in the following procedure:

- i) Turn off ("o") the power switch of the printer
- ii) Disconnect the AC inlet plug of the AC cable from the AC receptacle.
- iii) Disconnect the AC cable and interface cable from the printer.

(b) Reconnect the printer in the following procedure.

- i) Connect the AC cable and interface cable to the printer.
- ii) Connect the AC inlet plug to the AC receptacle.
- iii) Turn on ("I") the power switch of the printer.

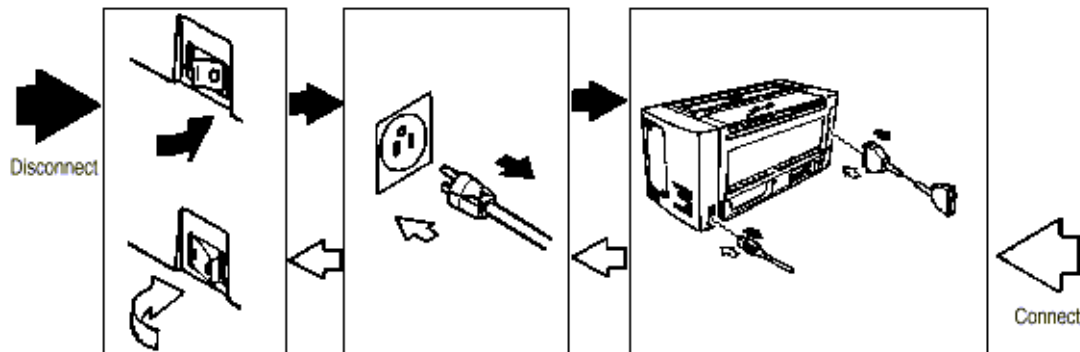

(2) Do not try disassembly as long as the printer is operating normally.

(3) Do not remove unnecessary parts: try to keep disassembly to a minimum.

(4) Use specified service tools.

(5) When disassembling, follow the determined sequence. Otherwise, parts may be damaged.

(6) Since screws, collars and other small parts are likely to be lost, they should temporarily be attached to the original positions.

(7) When handling ICs such as microprocessors, ROM and RAM, and circuit boards, do not wear gloves that are likely to generate static electricity.

(8) Do not place printed circuit boards directly on the equipment or floor.

(9) If adjustment is specified in the middle of installation, follow the instructions.

(10) Disassembly prohibited parts







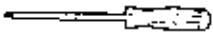
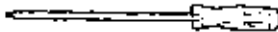

The following units and parts should not be disassembled because they cannot be reassembled if they are broken apart.)

Unit	Disassembly prohibited parts	Details
Printhead	Printhead	Printhead unit
Printer Unit	Space motor Ribbon pulse motor Autogap motor Tractor change motor Bail motor	Motor unit
Printer Unit	Eccentric collar (L) / (R) (within the bearing on the adjusting cam)	Eccentric collar fixing screw (white painted part)
Printer Unit	Gap sensor (AG sensor frame Assy)	Gap sensor fixing screw (white painted part)

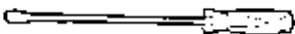
[Service Tools]

Table 3-1 shows the tools required for field replacement of printed circuit boards and units.

Table 3-1 Service Tools

No.	Service Tools	Q' ty	Place of use	Remarks
1	 No. 1-100 Philips screwdriver	1	2-2.5 mm screws	
2	 No. 2-250 Philips screwdriver, Magnetized	1	3-5 mm screws	
3	 No. 3-100 screwdriver	1		
4	 No. 5-250 screwdriver	1		
5	 Digital multimeter	1		
6	 Pliers	1		
7	 Tweezers	1		
8	 Feeler gauge 150MZ	1		
9	 1.1 lbs (500g) bar pressure gauge	1		
10	 No.5 Nippers	1		

3.2 Parts Layout

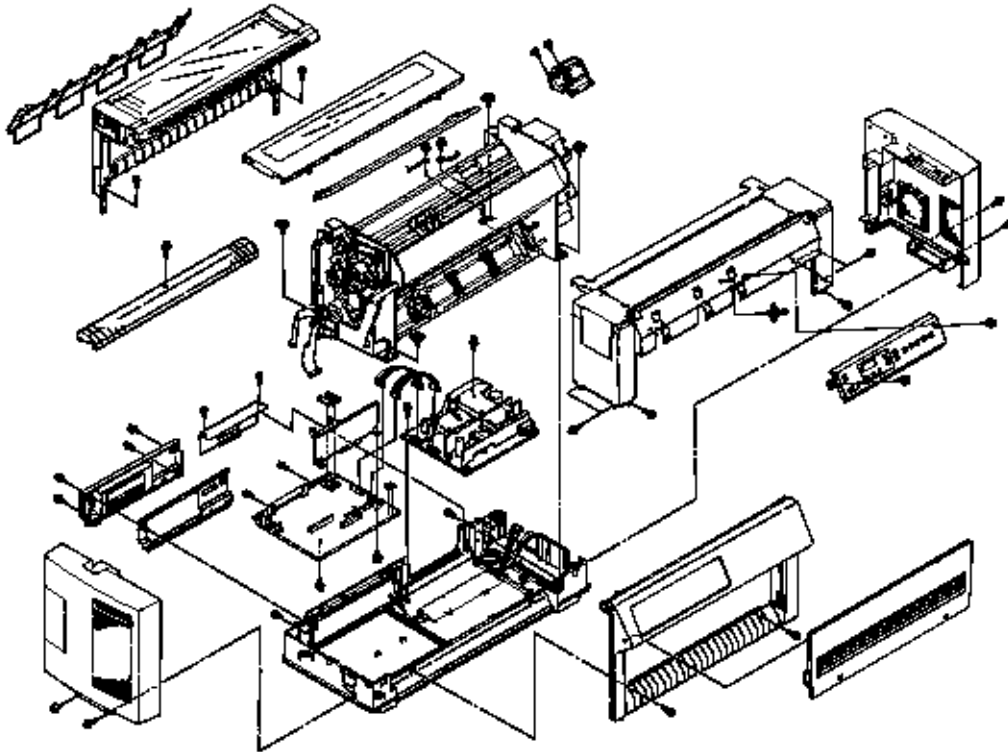



3.3 How to Change Parts

This section explains how to change parts and assemblies appearing in the disassembly diagram below.

3.3.1 Cover-Assy-Access / Cover-Assy-Side (R) / Cover-Assy-Side (L) / Cover-Assy-Front / Frame-Assy/Rear / Plate-Front (stuck)

3.3.2 Printer Unit

3.3.3 Control Block [Control Board (PMA Printed Board), Driver Board (PDA Printed Board)]

3.3.4 Power Supply Assy

3.3.5 PG Cooling Fan

3.3.6 I/F Board (PHA Printed Board)

3.3.7 AG Board (PGA Printed Board) / Connector Cord

3.3.8 AG Motor Assy

3.3.9 Mini Pitch Belt

3.3.10 Tractor Change Motor Assy

3.3.11 Bail Motor Assy

3.3.12 LF Motor Assy

3.3.13 Head Cooling Fan 1

3.3.14 Head Cooling Fan 2

3.3.15 Space Motor

3.3.16 Operator Board (POA Printed Board)

3.3.17 Ribbon Feed Assy

3.3.18 Printing Head

3.3.19 Head Cable

3.3.20 Ribbon Protector

3.3.21 Space Motor Fan

3.3.22 Junction Board

3.3.23 Cover Open Switch Assy / Ribbon Rotation Sensor

3.3.24 Interlock Switch / Interlock Switch Cord Assy

3.3.25 Knob Bracket Assy

3.3.26 Space Belt

3.3.27 AG Sensor Frame / Start Searching Sensor

3.3.28 Paper Jam Sensor Assy / Bail PE Sensor Assy

3.3.29 Sprocket assy (L) (R) (Front Tractor)

3.3.30 Sheet Feeder Assy (L) Rear / Sheet Feeder Assy (R) Rear

3.3.31 Bail Assy

Copyright 1998, Okidata, Division of OKI America, Inc. All rights reserved. See the OKIDATA Business Partner Exchange (BPX) for any updates to this material. (<http://bpx.okidata.com>)



Service Guide for PM4410

Chapter 3 Disassembly

3.3.1 Cover-Assy-Access / Cover-Assy-Side (R) / Cover-Assy-Side (L) / Cover-Assy-Front / Frame-Assy-Rear / Plate-Front (stuck)

- (1) Remove Guide Sheet (1) and Cover Assy Access (2).
- (2) Unscrew 2 screws (3) and the screw (4) and the screw (5), then remove Cover Assy Side (R) (6), sliding it to the arrow direction.
- (3) Unscrew 2 screws (7) and the screw (8) and the screw (9), then remove Cover Assy Side (L) (10), sliding it to the arrow direction.
- (4) Unscrew 4 screws (11) and the screw (12).
- (5) Release Hooks (13) then remove Cover Assy Front (14) and Door Assy Front (15).
- (6) Unscrew 4 screws (16) then lift and remove Frame Assy Rear (17).
- (7) Unscrew the screw (18) then remove Guide Paper (B) (19).
- (8) Unscrew 6 screws (20) then lift and remove Plate Front (stuck) (21).
- (9) Unscrew 4 screws (22) then remove Cover Rear B (23) and Plate Earth (Cover Rear) (24) together.
- (10) Unscrew 2 screws (25) then remove Cover Blank (lower) (26).
- (11) For installation, reverse the removal procedure.

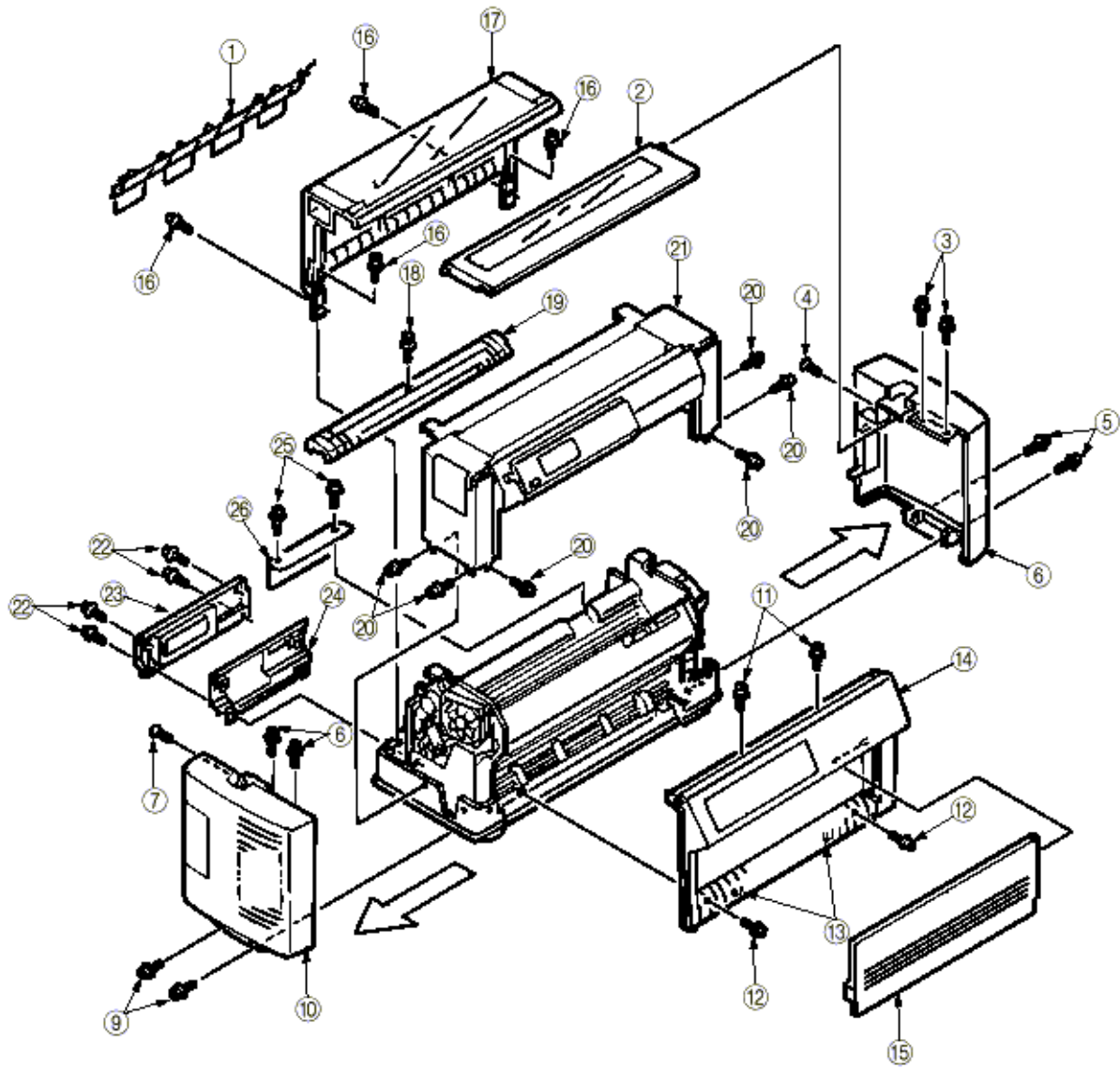

Copyright 1998, Okidata, Division of OKI America, Inc. All rights reserved. See the OKIDATA Business Partner Exchange (BPX) for any updates to this material. (<http://bpx.okidata.com>)



3.3.2 Printer Unit

(1) Remove Cover Assy Access / Cover Assy Side (R) / Cover Assy Side (L) / Cover Assy Front / Frame Assy Rear / Plate Front (stuck). (See 3.3.1)

(2) Unscrew 4 screws (2) which fix Printer Unit (1).

(3) Unplug I/F Connecting Cable (4) and Head Cable (5) from Control Board (3).

(4) Unplug the connector to Power Supply Assy (6) and unscrew 2 screws (8), then remove FG Wires (9).

(5) Unplug Junction Board Cord (10) from Junction Board (PRA Printed Board) (CN1).

(6) Unplug SP Slit Sensor Cord (11).

(7) With the handle (12) held, lift and remove Printer Unit (1).

(Note on Installation)

1. When lowering Printer Unit, prevent connection cords/cables from being caught under the unit. (Lifting and lowering Printer Unit require 2 or more maintenance personnel.)

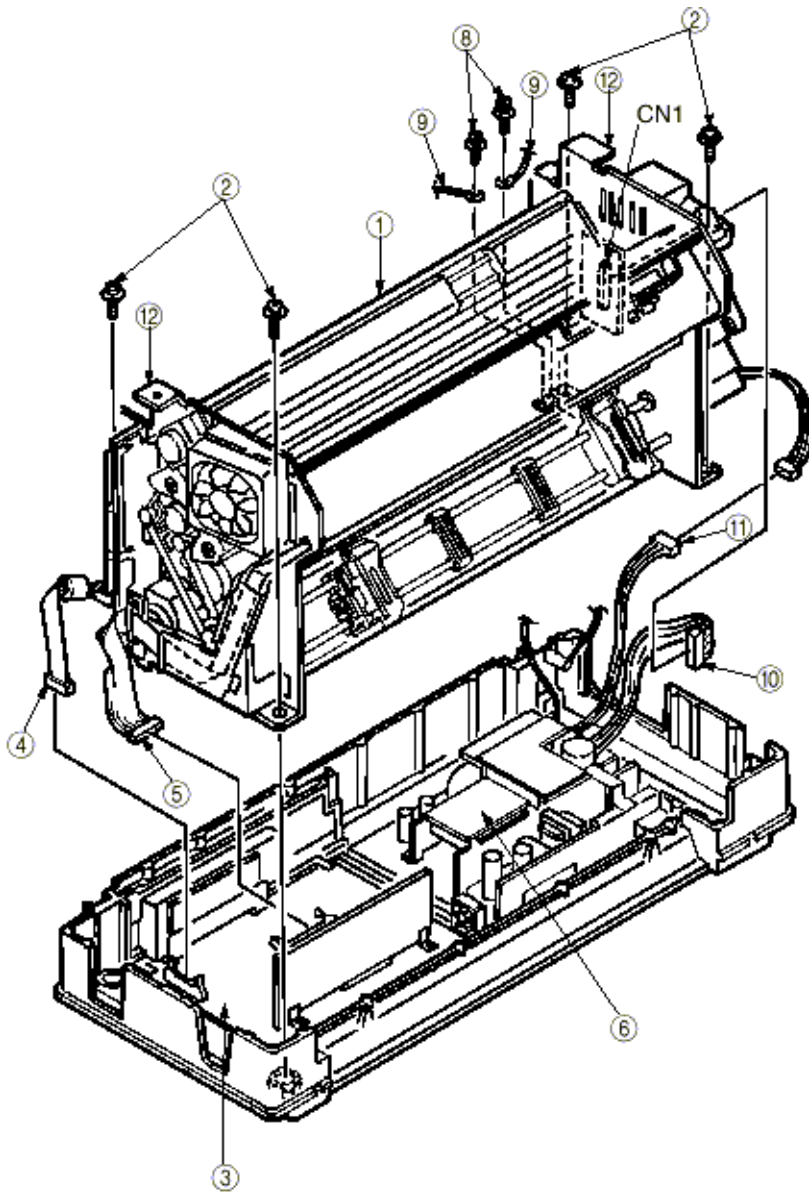

Copyright 1998, Okidata, Division of OKI America, Inc. All rights reserved. See the OKIDATA Business Partner Exchange (BPX) for any updates to this material. (<http://bpx.okidata.com>)



Service Guide for PM4410

Chapter 3 Disassembly

3.3.3 Control Block [Control Board (PMA Printed Board), Driver Board (PDA Printed Board)]

- (1) Remove Cover Rear (B). (See 3.3.1)
- (2) Unscrew 2 screws (1) and unplug all the connecting cords to Control Block (2).
- (3) Remove Control Block (2), sliding it into the arrow direction.

[Control Board (PMA Printed Board) and Driver Board (PDA Printed Board)] Unscrew 2 screws (3) then pull Driver Board (PDA Printed Board) (4) upward and release it from the connecting position to Control Board (PMA Printed Board) (5).

- (4) For installation, reverse the removal procedure.

(Note on Installation)

1. Prevent the connecting cords from being caught under Control Block (2).
2. Make sure Control Block (2) is fixed with 2 hooks on Lower Cover (6), when mounting the Unit.

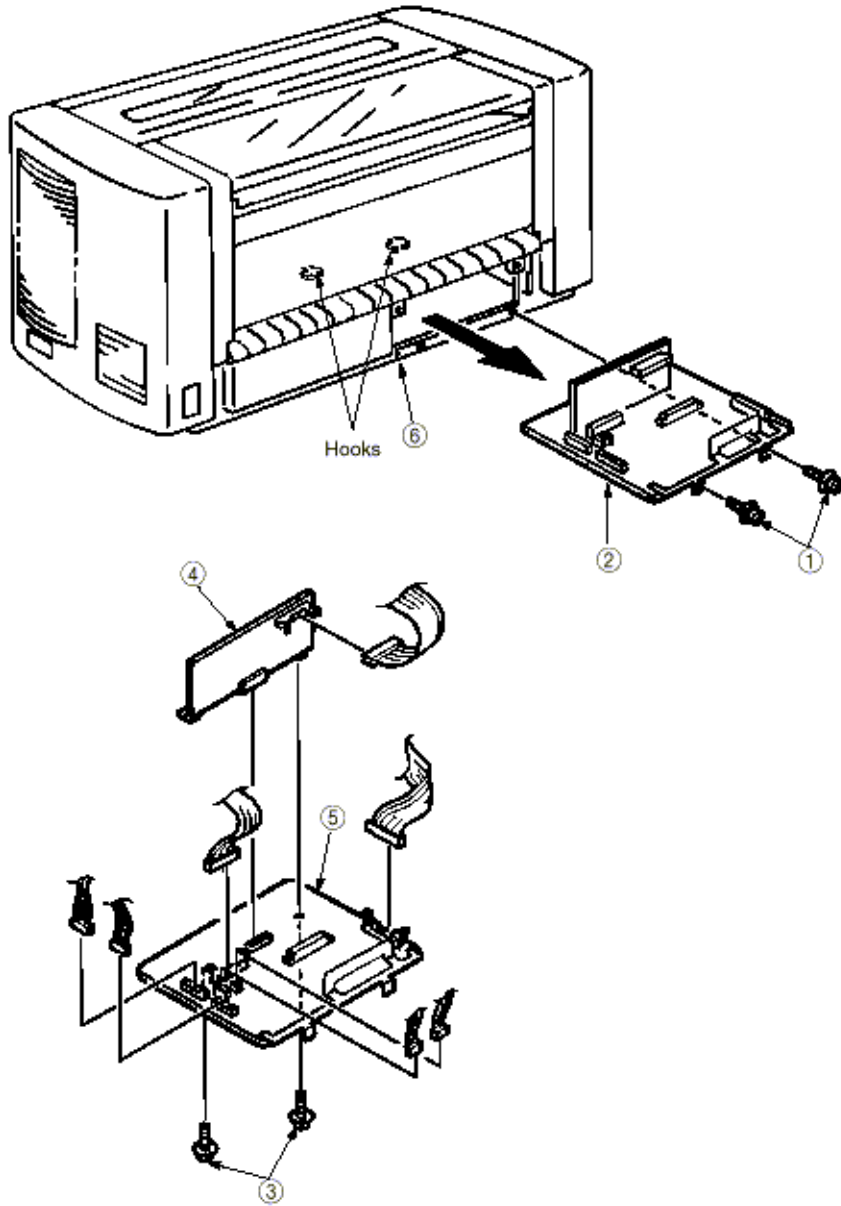

Copyright 1998, Okidata, Division of OKI America, Inc. All rights reserved. See the OKIDATA Business Partner Exchange (BPX) for any updates to this material. (<http://bpx.okidata.com>)

3.3.4 Power Supply Unit

- (1) Remove Guide Paper (B), Cover Blank Lower and Rear Cover (B). (See 3.3.1)
- (2) Unplug connectors to Power Supply Unit (1).
- (3) Unscrew the screw (2) and release Earth Wire (3).
- (4) Unscrew the screw (4) and remove Bracket PG (5).
- (5) Unscrew 2 screws (6). Pulling forward the protrusion on Power Supply Unit (1) and sliding it in the arrow direction through (2) inserting positions, remove Power Supply Unit.
- (6) For installation, reverse the removal procedure.

(Note on Installation)

1. Insert the protrusion on Power Supply Unit (1) into the inserting positions on Lower Cover (7) and mount the Unit.
2. The fan should be installed, matching the direction of air flow to the direction of arrow shown in the figure.

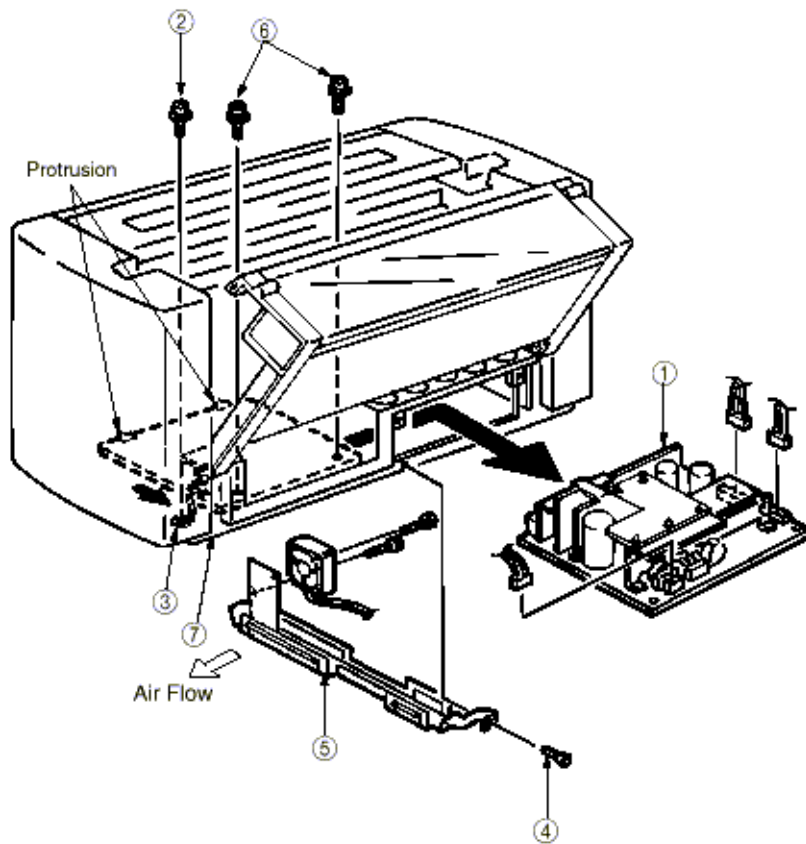

Copyright 1998, Okidata, Division of OKI America, Inc. All rights reserved. See the OKIDATA Business Partner Exchange (BPX) for any updates to this material. (<http://bpx.okidata.com>)

3.3.5 PG Cooling Fan

- (1) Remove Cover Assy Access / Cover Assy Side (R) / Cover Assy Side (L) / Cover Assy Front / Frame Assy Rear. (See 3.3.1)
- (2) Unplug the connectors (2) to Junction Board (PRA Printed Board) (CN13) (1).
- (3) Unscrew 2 screws (3) and remove PG Cooling Fan (4).
- (4) For installation, reverse the removal procedure.

(Note on Installation)

1. Mount the fan to produce wind in the direction as indicated on PG Fan Bracket (5).
2. The fan should be installed, matching the direction of air flow to the direction of arrow shown in the figure.

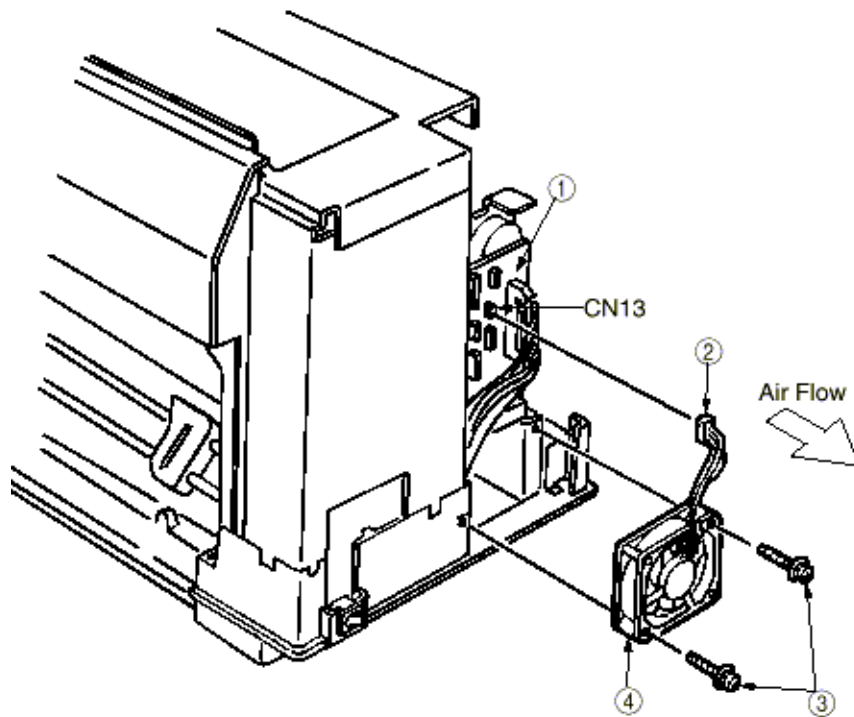

3.3.6 I/F Board (PHA Printed Board)

(1) Remove Cover Assy Access / Cover Assy Side (R) / Cover Assy Side (L) / Cover Assy Front / Frame Assy Rear / Plate Front (stuck). (See 3.3.1)

(2) Unscrew the screw (1) and remove Cable Holder (2).

(3) Unscrew 2 screws (3) and remove I/F Board Holder Cover (4).

(4) Unplug all the connectors to I/F Board (PHA Printed Board) (5).

(5) Unscrew the screw (6) and 4 screws (7), then remove I/F Board (PHA Printed Board) 5 and I/F Board Holder (8) together.

(6) Unscrew 2 screws (9) and remove I/F Board (PHA Printed Board) (5).

(7) For installation, reverse the removal procedure.

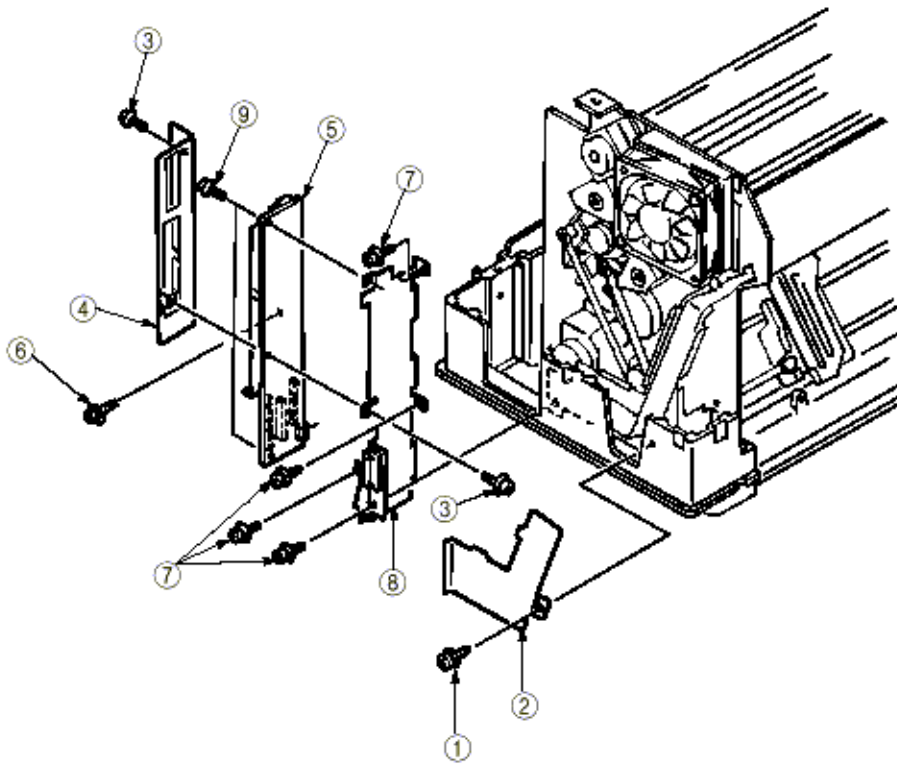



3.3.7 AG Board (PGA Printed Board) / Connector Cord

- (1) Remove Cover Assy Access / Cover Assy Side (R) / Cover Assy Side (L) / Cover Assy Front / Frame Assy Rear / Plate Front (stuck). (See 3.3.1)
- (2) Unplug the connectors (10) to Junction Board (PRA Printed Board) (CN3) (9).
- (3) Unscrew the screw (1).
- (4) Remove AG Board Holder A (2), AG Board (PGA Printed Board) (3) and AG Slit Sensor Cord (4) together.
- (5) Unscrew the screw (5) and release the wrapping tie (6), then remove AG Board (PGA Printed Board) (3) and unplug AG Slit Sensor Cord (4).
- (6) For installation, reverse the removal procedure.

(Note on Installation)

1. The distance to Slit Disk should be 0.5 mm or shorter.
2. Screwing down the screw (1), move Sensor Bracket (2) into the arrow direction to produce the following conditions:

Slit Disk (8) does not touch Sensor when Main Shaft (7) is shifted up to its right play end, and the gap should be 0.5 mm or shorter when Main Shaft (7) is shifted up to its left play end. (Check the above conditions for all Slit Disk (8) surface.)

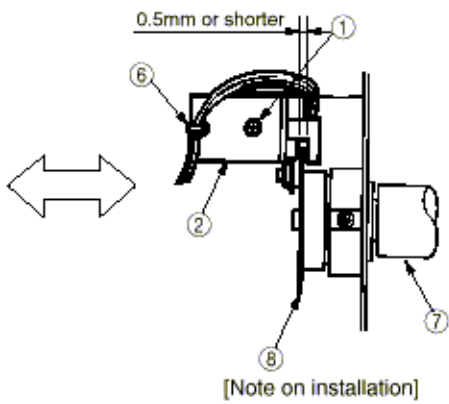
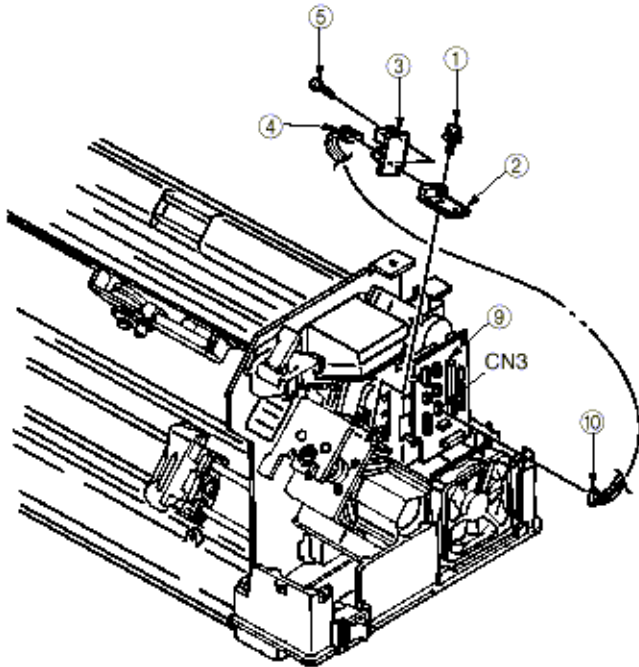

Copyright 1998, Okidata, Division of OKI America, Inc. All rights reserved. See the OKIDATA Business Partner Exchange (BPX) for any updates to this material. (<http://bpx.okidata.com>)



Service Guide for PM4410

Chapter 3 Disassembly

3.3.8 AG Motor Assy

(1) Remove Cover Assy Access / Cover Assy Side (R) / Cover Assy Side (L) / Cover Assy Front / Frame Assy Rear / Plate Front (stuck). (See 3.3.1)

(2) Unscrew 2 screws (1) and remove Bail Gear Assy (2).

(3) Unscrew 2 screws (3) and remove AG Motor Assy (4).

(4) Unscrew 2 screws (5) and remove Motor (6).

(5) Remove Idle Gear (7) and Tractor Idle Gear (8).

(6) For installation, reverse the removal procedure.

(Note on Installation)

1. Making sure Idle Gear C (7) and Tractor Idle Gear (8) with AG Motor Assy (2) rotate smoothly without play, mount the motor assy.

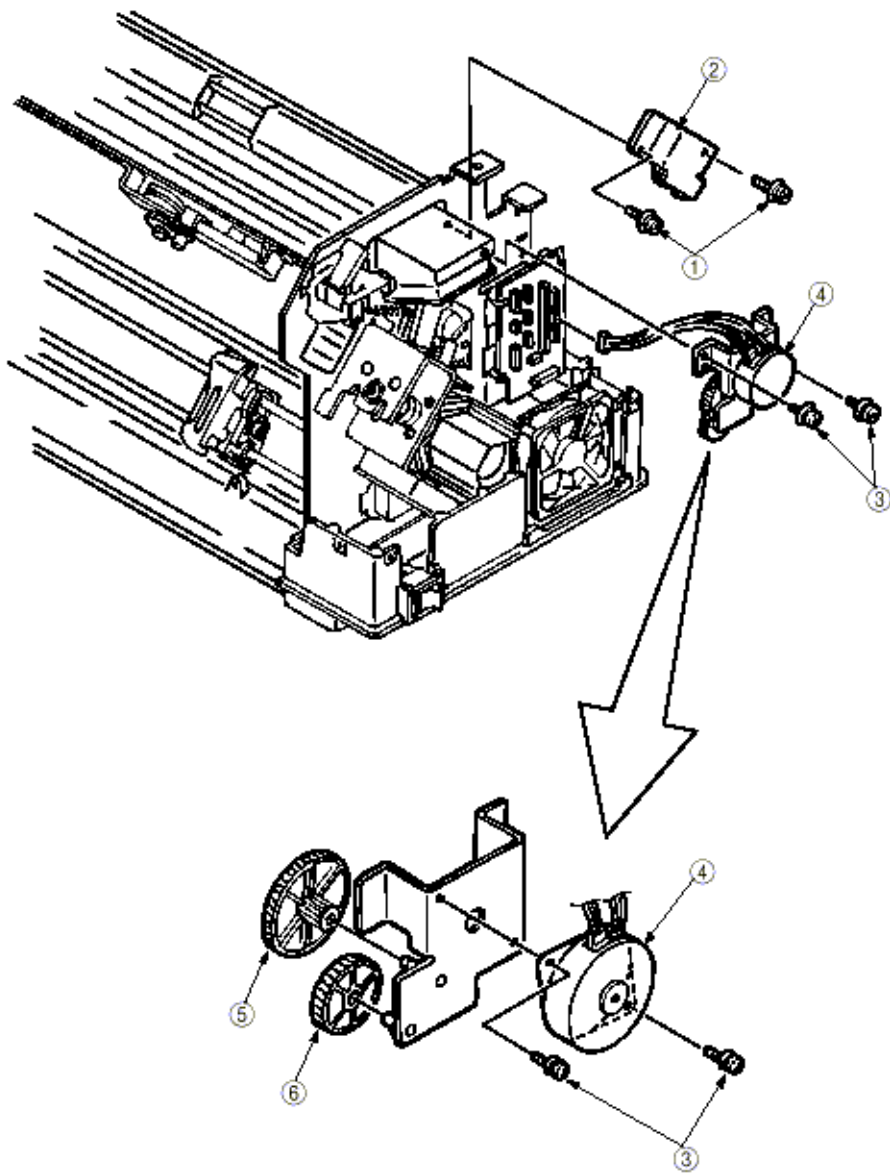

Copyright 1998, Okidata, Division of OKI America, Inc. All rights reserved. See the OKIDATA Business Partner Exchange (BPX) for any updates to this material. (<http://bpx.okidata.com>)

3.3.9 Mini Pitch Belt

(1) Remove Cover Assy Access / Cover Assy Side (R) / Cover Assy Side (L) / Cover Assy Front / Frame Assy Rear / Plate Front (stuck). (See 3.3.1)

(2) Unscrew 2 screws (1) and remove Shaft Support Plate (press fit) (2).

(3) Screw down the screw (3) and turn Idle Pulley Assy (4) into the right direction.

(4) Remove Mini Pitch Belt (5).

(5) For installation, reverse the removal procedure.

(Note on Installation)

1. Adjust the belt play after installing Mini Pitch Belt (5).

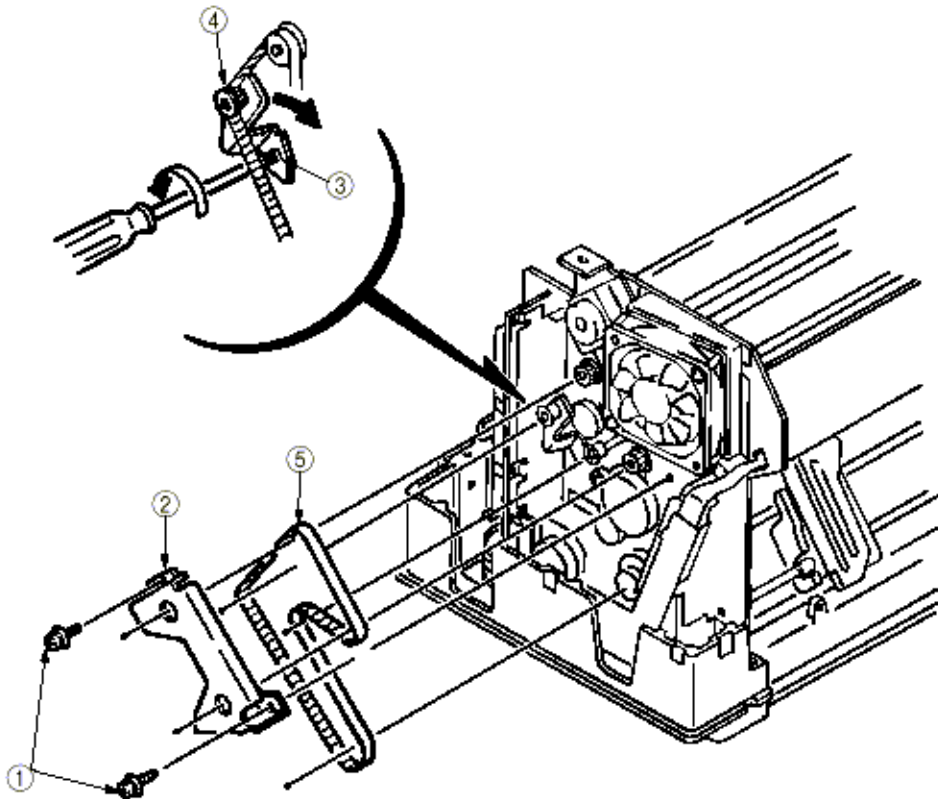



3.3.10 Tractor Change Motor Assy

- (1) Remove Cover Assy Access / Cover Assy Side (R) / Cover Assy Side (L) / Cover Assy Front / Frame Assy Rear / Plate Front (stuck). (See 3.3.1)
- (2) Remove Printer Unit. (See 3.3.2)
- (3) Remove I/F Board. (See 3.3.6)
- (4) Release the cords from Cord Clamp (3) on the cord route.
- (5) Unscrew 2 screws (4) and remove Cable Holder (5).
- (6) Unscrew the screw (6) and cut the wrapping tie (7).
- (7) Remove Micro Switch (8).
- (8) Unscrew 2 screws (9) and remove Tractor Change Motor Assy (10).
- (9) Remove E rings (11) and the gear (12).
- (10) Unscrew 2 screws (13) and remove Motor (14).
- (11) For installation, reverse the removal procedure.

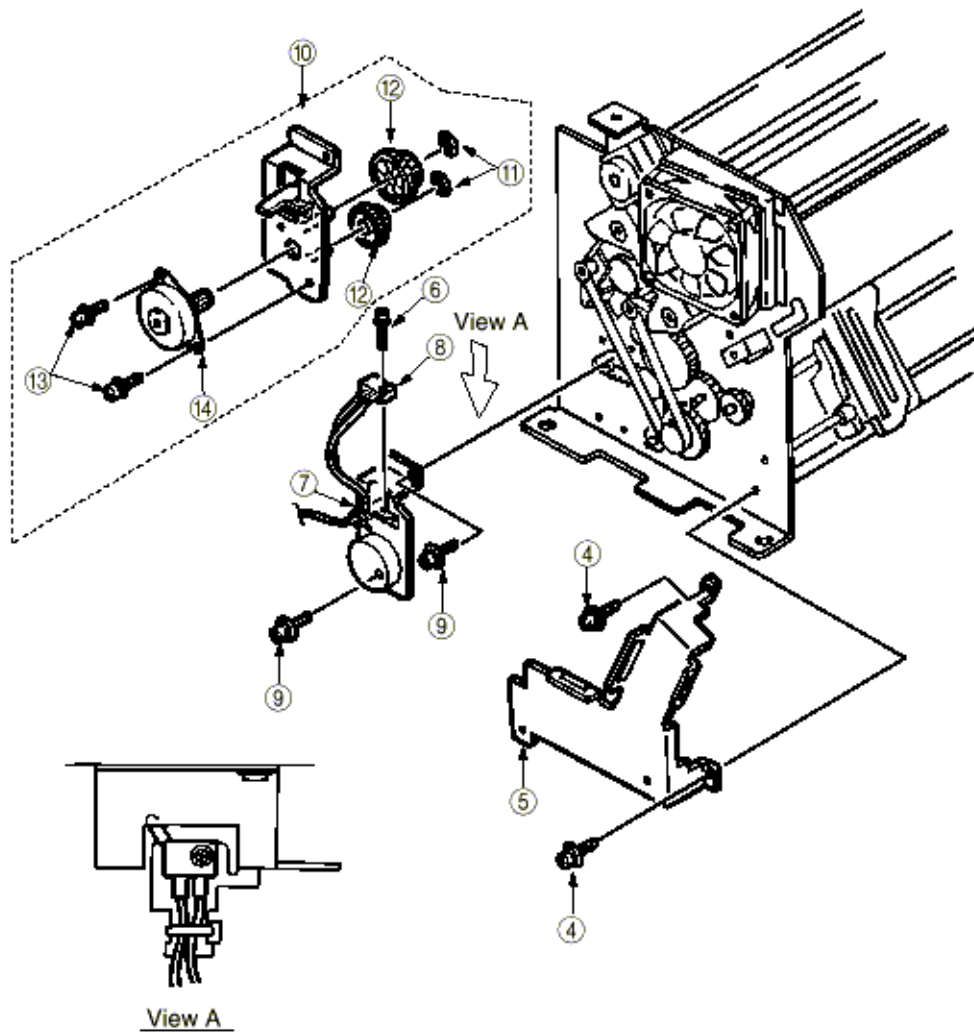

Copyright 1998, Okidata, Division of OKI America, Inc. All rights reserved. See the OKIDATA Business Partner Exchange (BPX) for any updates to this material. (<http://bpx.okidata.com>)



3.3.11 Bail Motor Assy

- (1) Remove Cover Assy Access / Cover Assy Side (R) / Cover Assy Side (L) / Cover Assy Front / Frame Assy Rear / Plate Front (stuck). (See 3.3.1)
- (2) Unplug the connectors (1) from I/F Board (PHA Printed Board) (CN2) (12).
- (3) Unplug the connectors (11) from I/F Board (PHA Printed Board) (CN11) (12).
- (4) Release the cords from the cord clamps on the cord route.
- (5) Unscrew the screw (2) and cut the wrapping tie.
- (6) Remove Micro Switch (3).
- (7) Unscrew 2 screws (4) and remove Bail Motor Assy (5).
- (8) Unscrew 2 screws (6) and remove the motor (7).
- (9) Remove E rings (8) and 2 gears (9) and (10).
- (10) For installation, reverse the removal procedure.

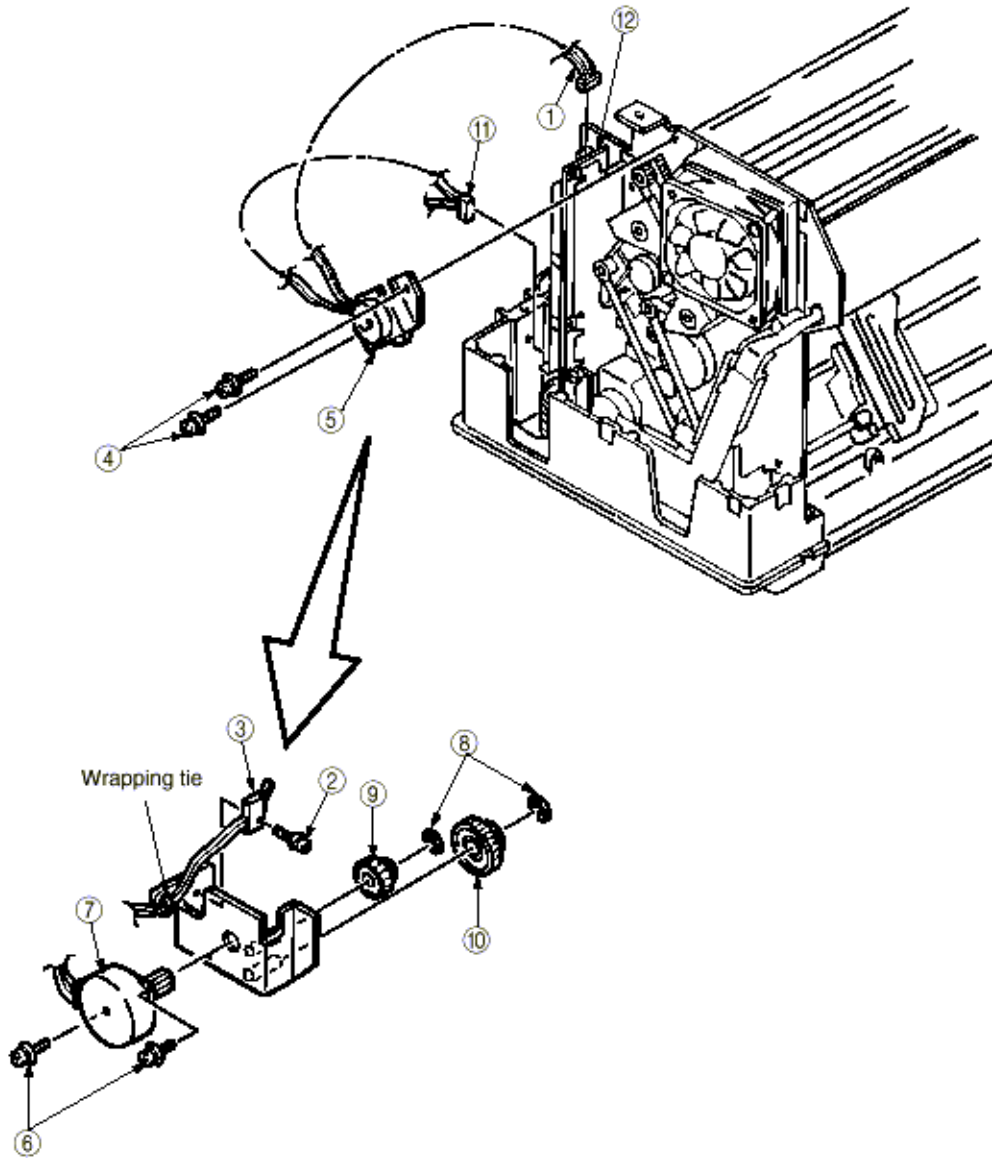

Copyright 1998, Okidata, Division of OKI America, Inc. All rights reserved. See the OKIDATA Business Partner Exchange (BPX) for any updates to this material. (<http://bpx.okidata.com>)



3.3.12 LF Motor Assy

- (1) Remove Cover Assy Access / Cover Assy Side (R) / Cover Assy Side (L) / Cover Assy Front / Frame Assy Rear / Plate Front (stuck). (See 3.3.1)
- (2) Remove I/F Board. (See 3.3.6).
- (3) Remove Printer Unit. (See 3.3.2).
- (4) Remove Tractor Change Motor Assy. (See 3.3.10).
- (5) Unscrew 3 screws (1) and remove LF Motor (2).
- (6) For installation, reverse the removal procedure.

(Note on Installation)

1. LF Motor Assy (2) should be mounted with the cord route as shown below.

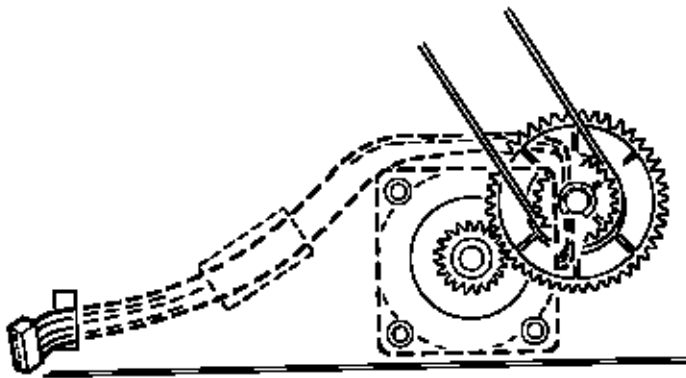
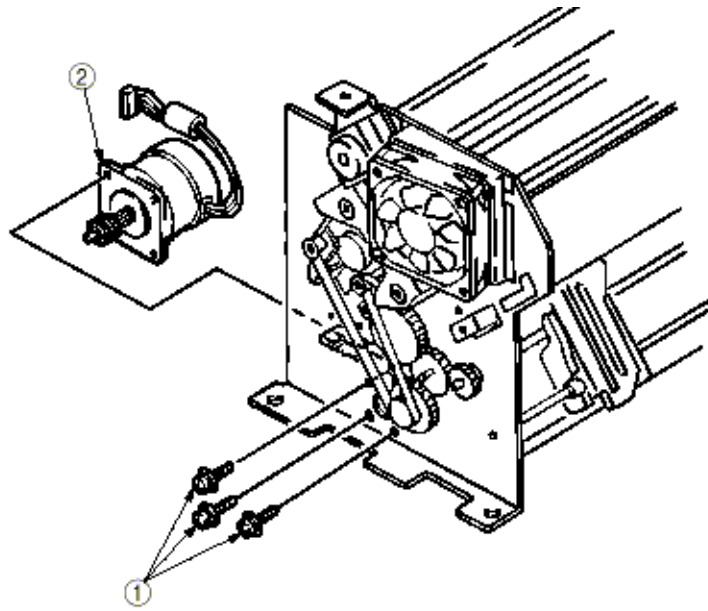

[LF Motor Assy Cord Route Fig.]

3.3.13 Head Cooling Fan 1

- (1) Remove Cover Assy Access / Cover Assy Side (R) / Cover Assy Side (L) / Cover Assy Front / Frame Assy Rear / Plate Front (stuck). (See 3.3.1)
- (2) Unplug the connector (1) from Junction Board (PRA Printed Board) (CN6) (6).
- (3) Release the cords from the cord clamps on the cord route.
- (4) Unscrew 2 screws (2) and remove SP Motor Fan Assy (3).
- (5) Unscrew 2 screws (5) and remove Head Cooling Fan 1 (5).
- (6) For installation, reverse the removal procedure.

(Note on Installation)

1. The fan should be installed, matching the direction of air flow to the direction of arrow shown in the figure.

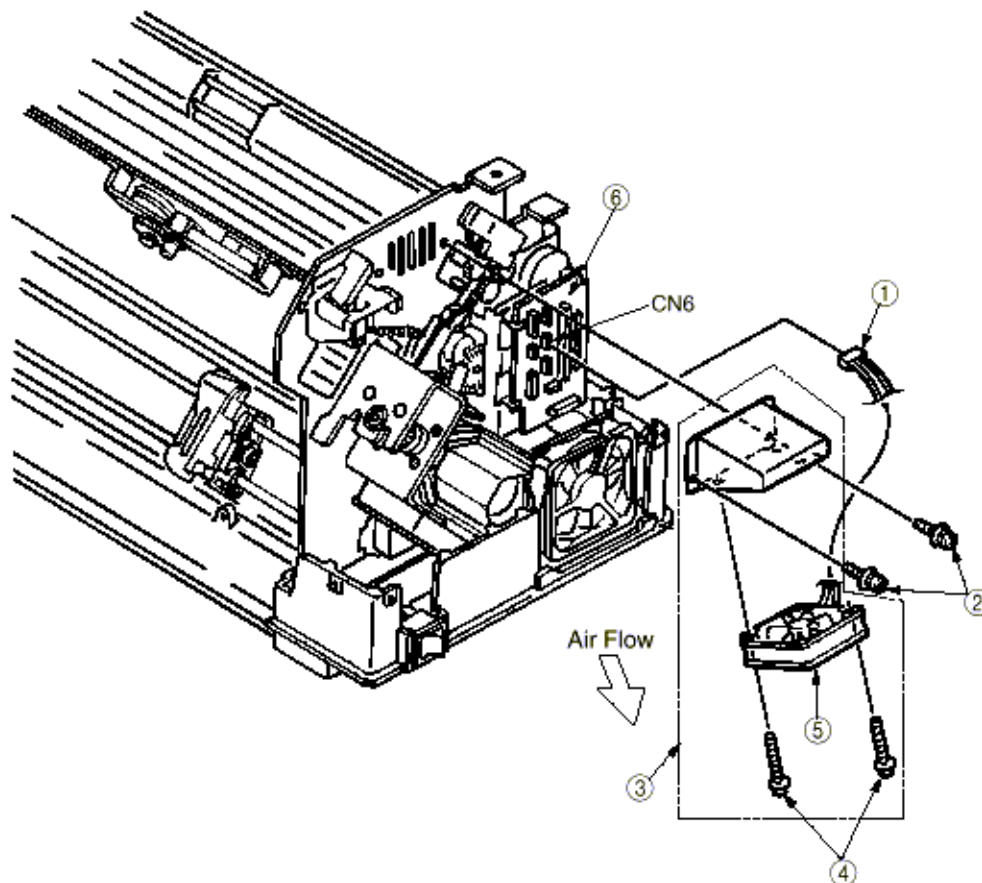

3.3.14 Head Cooling Fan 2

(1) Remove Cover Assy Access / Cover Assy Side (R) / Cover Assy Side (L) / Cover Assy Front / Frame Assy Rear / Plate Front (stuck). (See 3.3.1)

(2) Unscrew the screw (1) and remove Cable Holder Cover (2).

(3) Unplug the connector (3) from I/F Board (PHA Printed Board) (CN6) (6).

(4) Release the cords from the cord clamps on the cord route.

(5) Unscrew 2 screws (4) and remove Head Cooling Fan 2 (5).

(6) For installation, reverse the removal procedure.

(Note on Installation)

1. The fan should be installed, matching the direction of air flow to the direction of arrow shown in the figure.

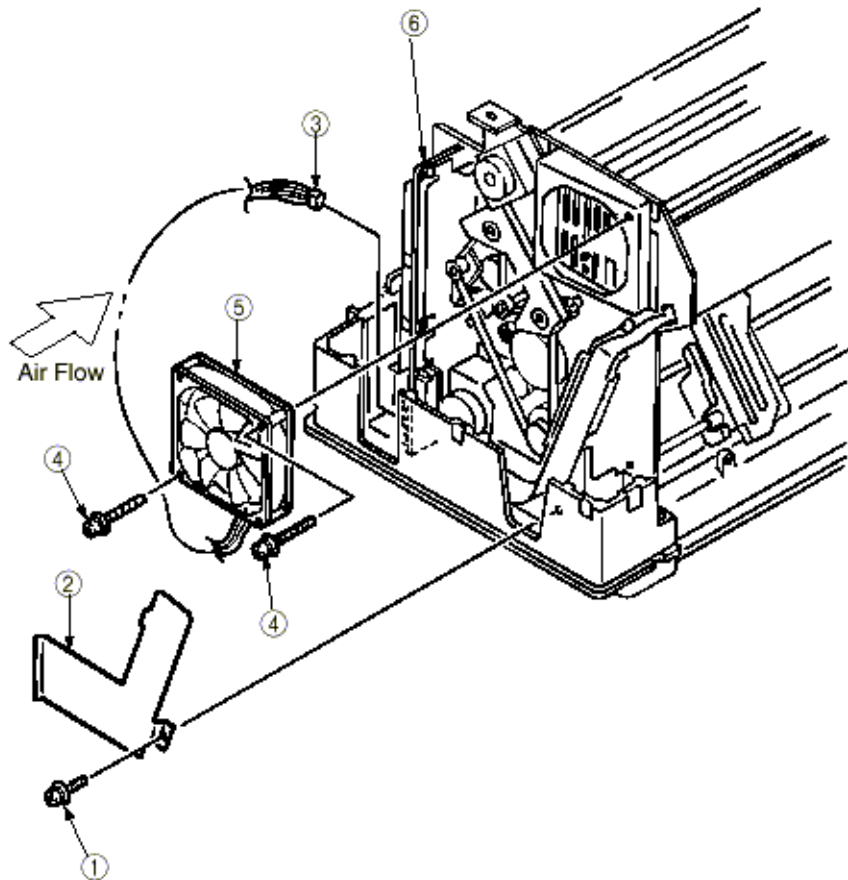

Copyright 1998, Okidata, Division of OKI America, Inc. All rights reserved. See the OKIDATA Business Partner Exchange (BPX) for any updates to this material. (<http://bpx.okidata.com>)



3.3.15 Space Motor

- (1) Remove Cover Assy Access / Cover Assy Side (R) / Cover Assy Side (L) / Cover Assy Front / Frame Assy Rear / Plate Front (stuck). (See 3.3.1)
- (2) Remove Printer Unit. (See 3.3.2)
- (3) Remove the stopper (1).
- (4) Screw down 2 fixing screws (2) on Idle Pulley Bracket. Move the pulley into the arrow direction to loose the belt, then fasten the screws.
- (5) Remove PG Cooling Fan. (See 3.3.5)
- (6) Unscrew 2 screws (4) and remove PG Fan Bracket (5).
- (7) Unplug connectors (7) to Interlock Switch Cord Assy (12).
- (8) Unplug connectors (8), (9) to Interlock Switch (10), and release the cords from the cord clamps on the cord route.
- (9) Unscrew 1 screws (13) and remove FG Mesh (3).
- (10) Unscrew 4 screws (11) and remove Space Motor (6).
- (11) For installation, reverse the removal procedure.

(Note on Installation)

1. After assembling the motor, adjust the position of the idle pulley bracket with screw (2) so that the space belt should be positioned at the center between the idle pulley and motor pulley, and the vertical fluctuation of belt be 0.5mm or less when the carriage is shifted to right and left. When the carriage is shifted to right and left, press the interlock switch (10) off so that the load of shifting it can be reduced.

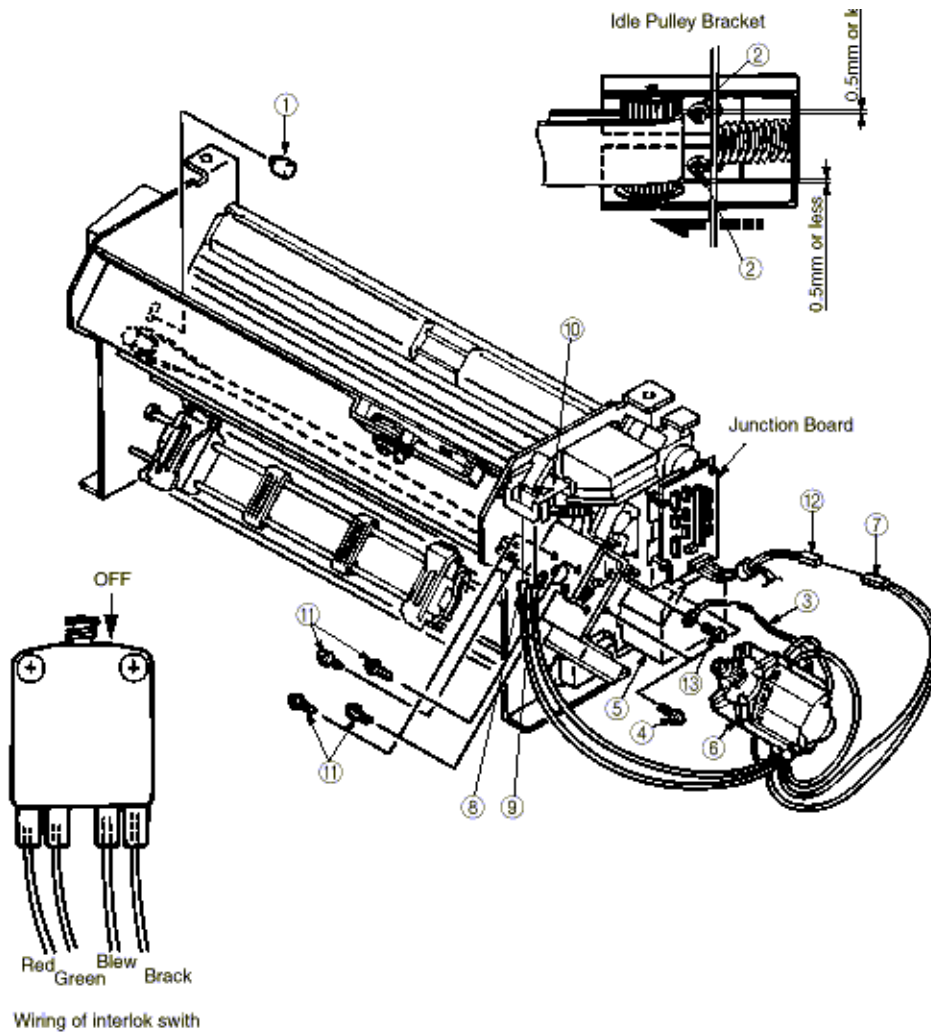

Copyright 1998, Okidata, Division of OKI America, Inc. All rights reserved. See the OKIDATA Business Partner Exchange (BPX) for any updates to this material. (<http://bpx.okidata.com>)



3.3.16 Operator Board (POA Printed Board)

(1) Remove Cover Assy Access / Cover Assy Side (R) / Cover Assy Side (L) / Cover Assy Front / Frame Assy Rear / Plate Front (stuck). (See 3.3.1)

(2) Unplug the connector (2) from Operator Board (POA Printed Board) (CN1) (1).

(3) Unscrew 2 screws (3) and Remove Operator Block Assy (4).

(4) Unplug the connector (8) from Operator Board (POA Printed Board) (CN2) (1).

(5) Unscrew 3 screws (5) and release 3 claws, then remove Operator Board (POA Printed Board) (1) from Operator Block Assy (4).

(6) Unscrew 4 screws (6) and remove LCD Unit (7).

(7) For installation, reverse the removal procedure.

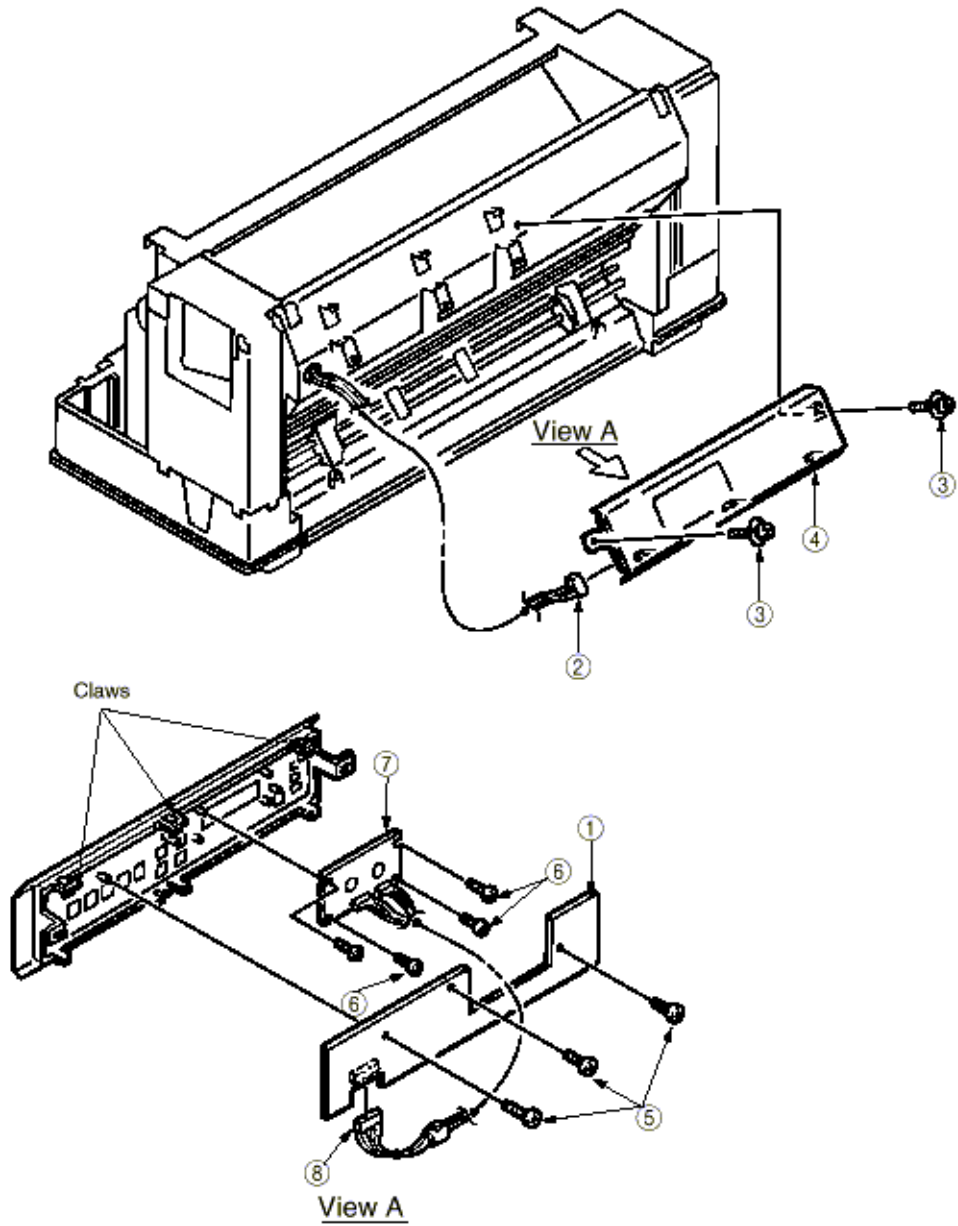

Copyright 1998, Okidata, Division of OKI America, Inc. All rights reserved. See the OKIDATA Business Partner Exchange (BPX) for any updates to this material. (<http://bpx.okidata.com>)

3.3.17 Ribbon Feed Assy

- (1) Remove Cover Assy Access / Cover Assy Side (R) / Cover Assy Side (L) / Cover Assy Front / Frame Assy Rear / Plate Front (stuck). (See 3.3.1)
- (2) Unplug the connector (1) from Junction Board (PRA Printed Board) (CN9) (7).
- (3) Unscrew 2 screws (2) and remove Ribbon Feed Assy (3).
- (4) Release the cord wrapping tie (4) and unscrew 2 screws (5), then remove the motor (6).
- (5) For installation, reverse the removal procedure.

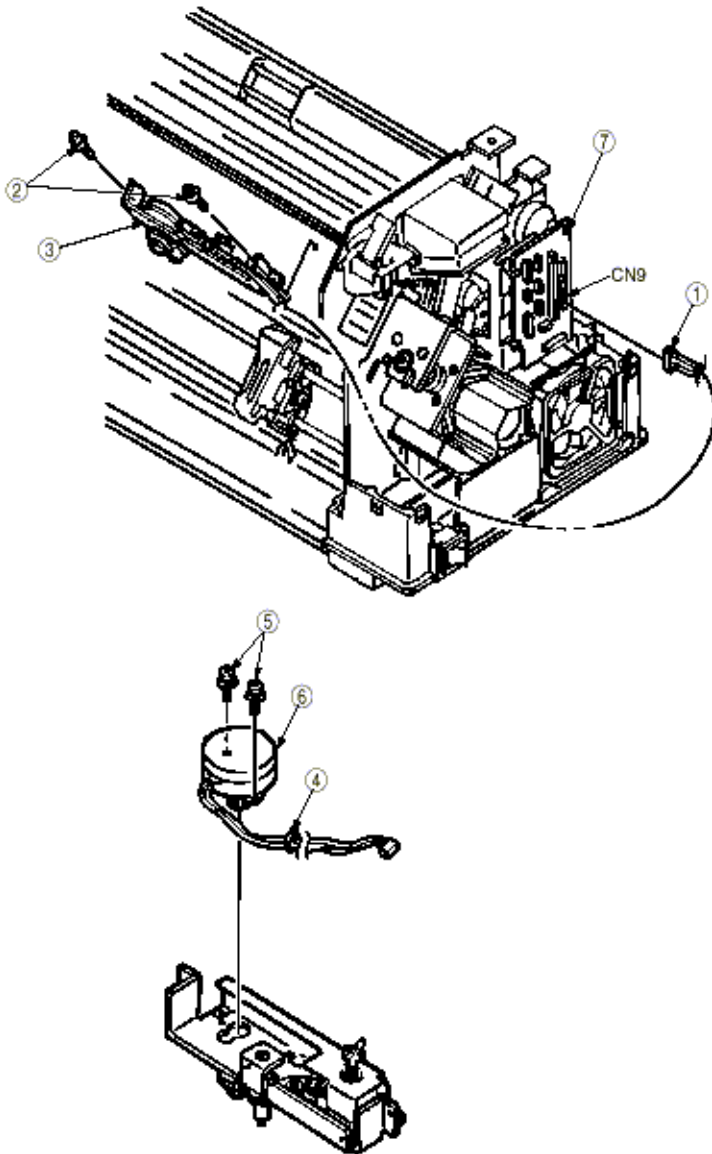

Copyright 1998, Okidata, Division of OKI America, Inc. All rights reserved. See the OKIDATA Business Partner Exchange (BPX) for any updates to this material. (<http://bpx.okidata.com>)



3.3.18 Printing Head

- (1) Lean Frame Assy Rear backward and open Access Cover.
- (2) Move the printing head to the recess on the right seen from the front.
- (3) Pull out Ribbon Guide (1) upward.
- (4) Unscrew 2 screws (2) and remove Printing Head (3) from the connector.
- (5) For installation, reverse the removal procedure.

(Note on Installation)

1. The head should be installed according to Section 9, Procedure for Installing Printhead in Chapter 4 ADJUSTMENTS.

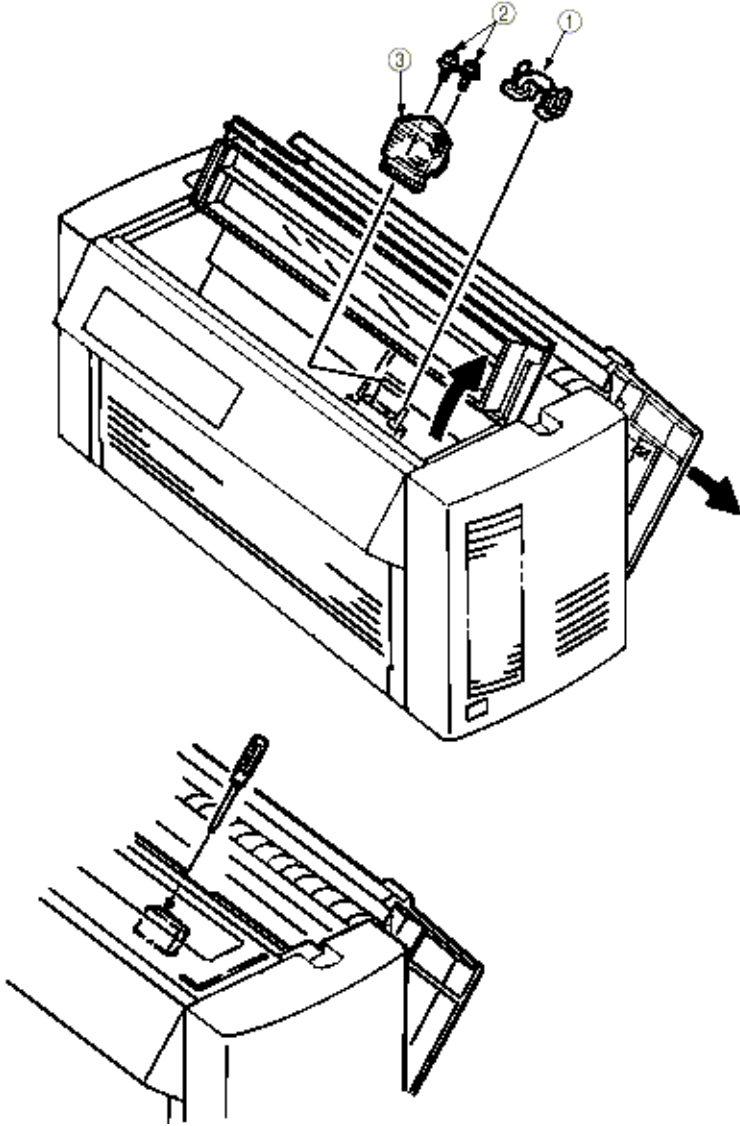

Copyright 1998, Okidata, Division of OKI America, Inc. All rights reserved. See the OKIDATA Business Partner Exchange (BPX) for any updates to this material. (<http://bpx.okidata.com>)



3.3.19 Head Cable

- (1) Remove Cover Assy Access / Cover Assy Side (R) / Cover Assy Side (L) / Cover Assy Front / Frame Assy Rear / Plate Front (stuck). (See 3.3.1)
- (2) Remove Printing Head. (See 3.3.18)
- (3) Remove Printer Unit. (See 3.3.2)
- (4) Remove Cable Holder Cover. (See 3.3.6)
- (5) Unscrew the screw (1) and remove Carriage Cable Holder (2).
- (6) Unplug Head Connector (3) and then the connector (green) (4).
- (7) Unscrew 2 screws (5) and remove Head Cable Cover (6).
- (8) Unplug Head Cable (7), pulling it to the left.
- (9) For installation, reverse the removal procedure.

(Note on Installation)

1. When the head cable is assembled, make sure that 0.5 - 1.5mm clearance exists between cables. The side frame (R) should protrude approx. 10mm when the carriage is moved to the left side of the printer.

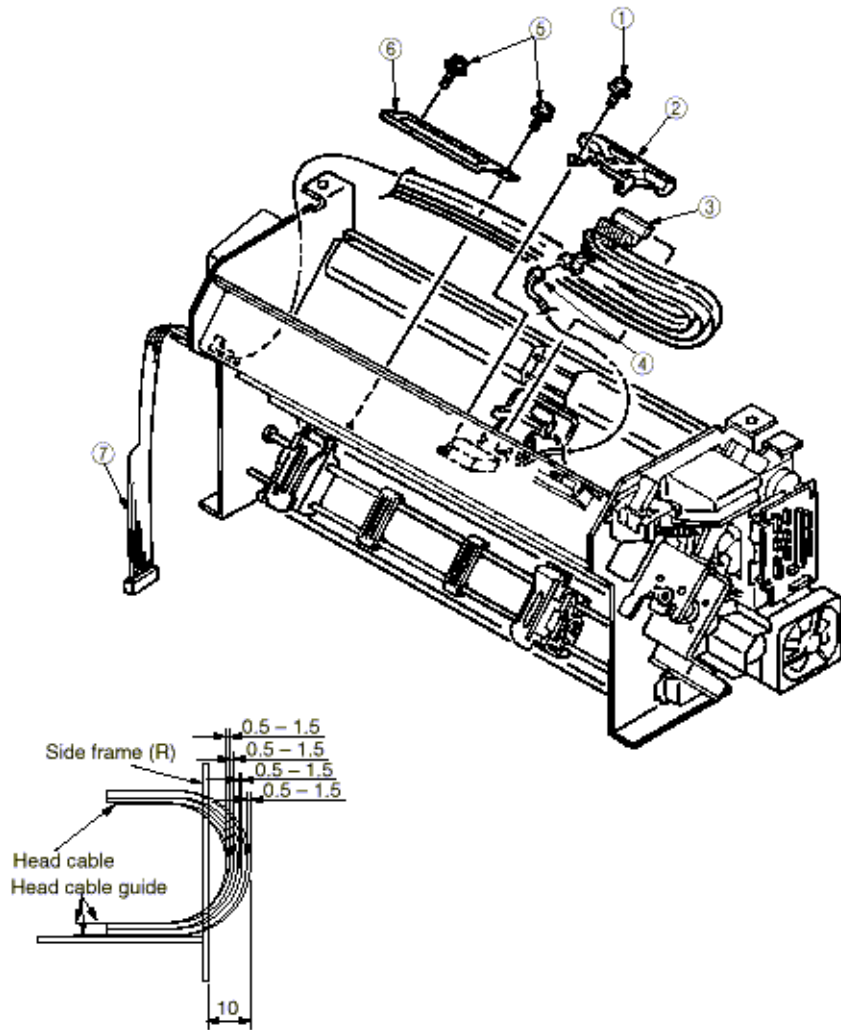

The condition of cables when the carriage is shifted to the left end



3.3.20 Ribbon Protector

- (1) Remove Printing Head. (See 3.3.18)
- (2) Open Access Cover (1).
- (3) Unscrew the screw (2) and remove the cord clamp (3).
- (4) Unscrew the screw (4) and remove Paper Width Sensor (5).
- (5) Unplug the connector (6).
- (6) Remove 2 Ribbon Guide Posts (7) and 2 washers (8).
- (7) Remove Ribbon Protector (9).
- (8) For installation, reverse the removal procedure.

(Note on Installation)

1. In assembling the ribbon protector, make an adjustment according to the Section 1 (2) Protector Gap of Chapter 4. ADJUSTMENTS.

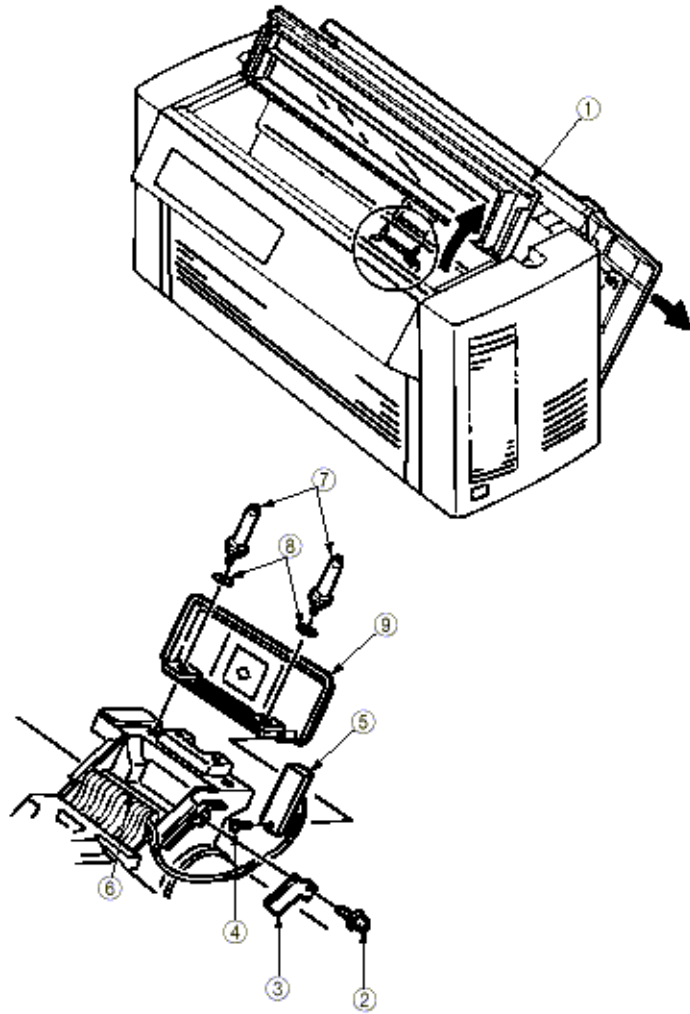

Copyright 1998, Okidata, Division of OKI America, Inc. All rights reserved. See the OKIDATA Business Partner Exchange (BPX) for any updates to this material. (<http://bpx.okidata.com>)

3.3.21 Space Motor Fan

(1) Remove Cover Assy Access / Cover Assy Side (R) / Cover Assy Side (L) / Cover Assy Front / Frame Assy Rear / Plate Front (stuck). (See 3.3.1)

(2) Remove Printer Unit. (See 3.3.2)

(3) Unscrew 2 screws (1) and unplug the connector (2) from Junction Board (PRA Printed Board) (CN12) (4), then remove Space Motor Fan (3).

(4) For installation, reverse the removal procedure.

(Note on Installation)

1. The fan should be installed, matching the direction of air flow to the direction of arrow shown in the figure.

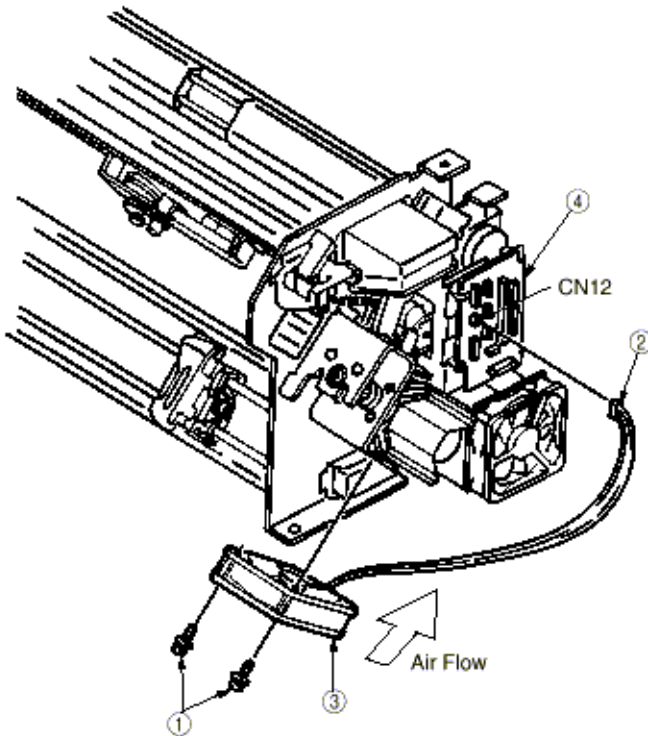

3.3.22 Junction Board

- (1) Remove Cover Assy Access / Cover Assy Side (R) / Cover Assy Side (L) / Cover Assy Front / Frame Assy Rear / Plate Front (stuck). (See 3.3.1)
- (2) Unplug all the connectors from the above.
- (3) Unscrew 2 screws (1) and remove Junction Board (PRA Printed Board) (2).
- (4) Unscrew 3 screws (3) and remove Junction Board Bracket (4).
- (5) For installation, reverse the removal procedure.

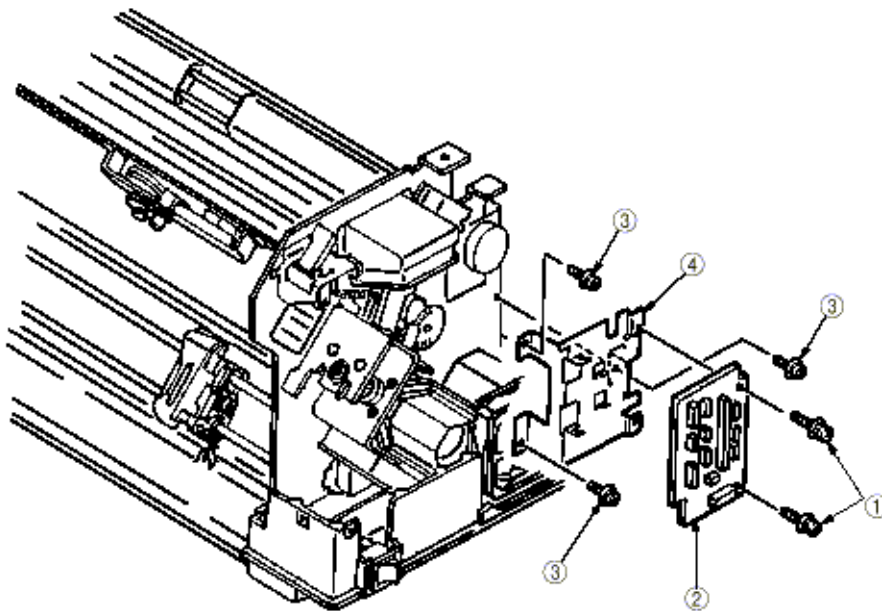

3.3.23 Cover Open Switch Assy / Ribbon Rotation Sensor

(1) Remove Cover Assy Access / Cover Assy Side (R) / Cover Assy Side (L) / Cover Assy Front / Frame Assy Rear / Plate Front (stuck). (See 3.3.1)

(2) Remove Head Cooling Fan (1). (See 3.3.13)

(3) Unscrew the screw (1) and 2 screws (2), and remove Ribbon Bracket (3).

(4) Unplug the connector (4) from Junction Board (PRA Printed Board) (CN4) (8), then remove Cover Open Switch Assy / Ribbon Rotation Sensor (5).

(5) Unscrew 2 screws (6) and remove Cover Open Switch Assy (7).

(6) For installation, reverse the removal procedure.

(Note on Installation)

1. In assembling the microswitch, position it until backlash is removed.

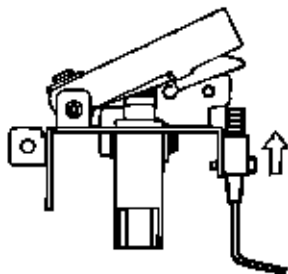
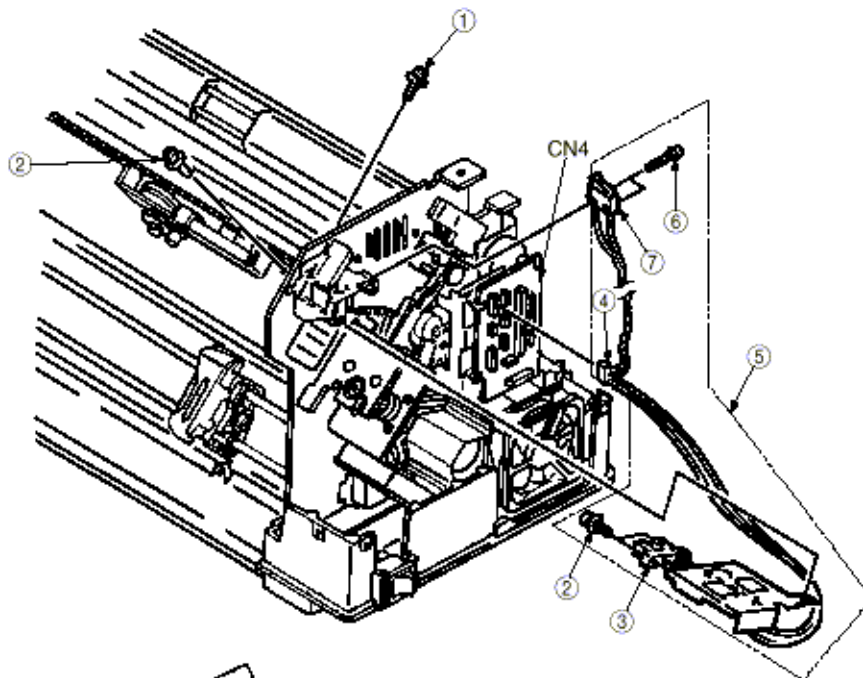

Note1

In installing the microswitch, raise it in the direction of arrow until backlash is removed.

MicroSW assembly detail

Copyright 1998, Okidata, Division of OKI America, Inc. All rights reserved. See the OKIDATA Business Partner Exchange (BPX) for any updates to this material. (<http://bpx.okidata.com>)

3.3.24 Interlock Switch / Interlock Switch Cord Assy

- (1) Remove Cover Assy Access / Cover Assy Side (R) / Cover Assy Side (L) / Cover Assy Front / Frame Assy Rear / Plate Front (stuck). (See 3.3.1)
- (2) Unplug 4 cables (1).
- (3) Unscrew 2 screws (2) and remove Interlock Switch (3).
- (4) Unplug 6 connectors (8).
- (5) Unplug connectors (4) to Spacing motor code (5).
- (6) Unplug Interlock Switch Cord Assy (7) from the cable clamp.
- (7) For installation, reverse the removal procedure.

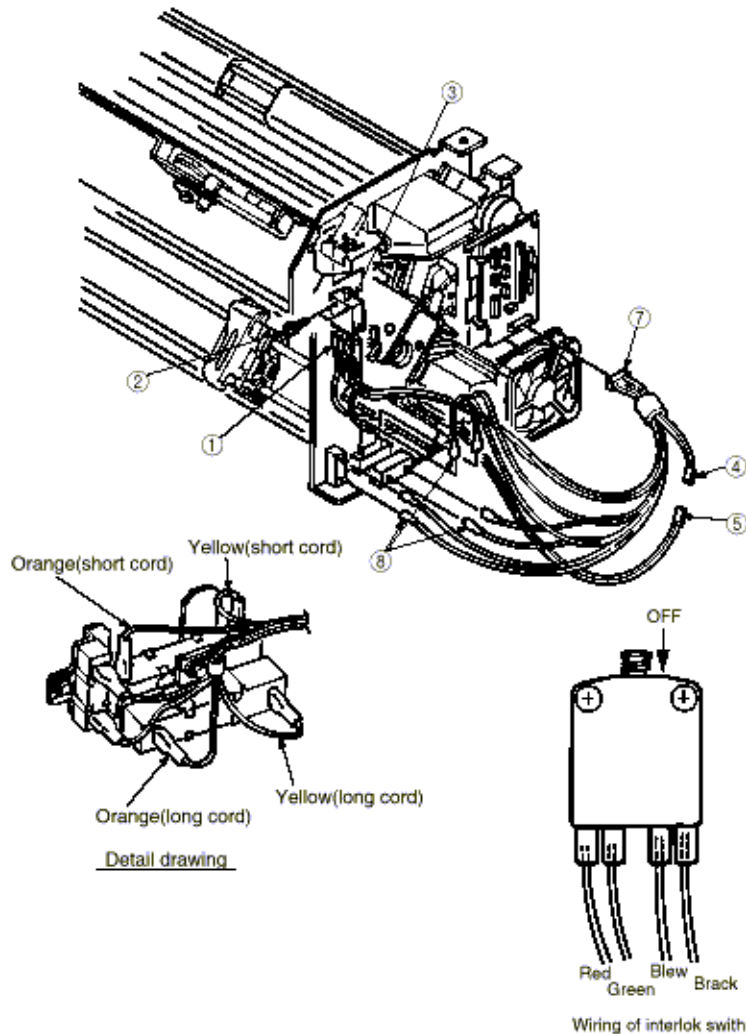

Copyright 1998, Okidata, Division of OKI America, Inc. All rights reserved. See the OKIDATA Business Partner Exchange (BPX) for any updates to this material. (<http://bpx.okidata.com>)



3.3.25 Knob Bracket Assy

- (1) Remove Bail Motor. (See 3.3.11)
- (2) Unscrew the screw (1) and remove the gear (2).
- (3) Unscrew 2 screws (3) and remove Knob Bracket Assy (4).
- (4) Unscrew 2 screws (5) and remove AG Sensor Cover (6).
- (5) Unscrew the screw (7) and remove Knob Cover (8).
- (6) Remove the E-ring (9), Gear (10) and Adjusting Knob (11).
- (7) Remove Spring Pin (12), then remove Idle Gear Shaft (13) and CSF Drive Shaft (14).
- (8) For installation, reverse the removal procedure.

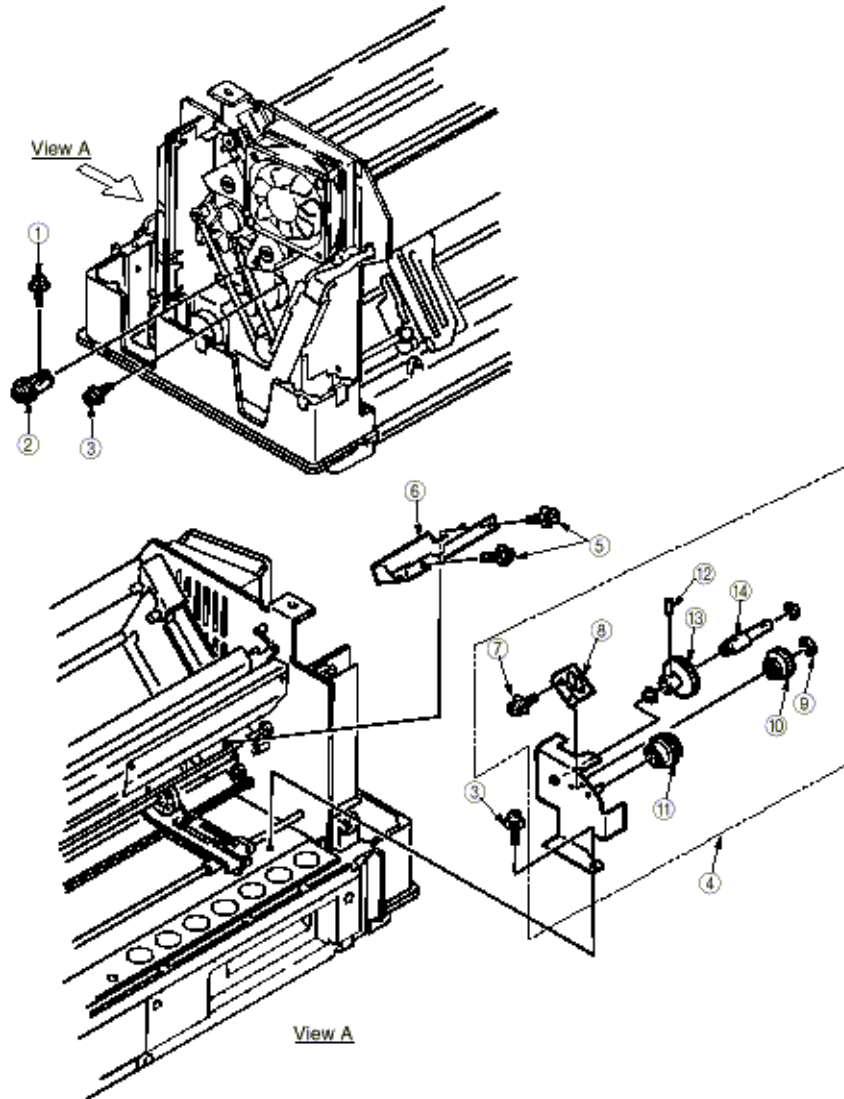

Copyright 1998, Okidata, Division of OKI America, Inc. All rights reserved. See the OKIDATA Business Partner Exchange (BPX) for any updates to this material. (<http://bpx.okidata.com>)

3.3.26 Space Belt

- (1) Remove Cover Assy Access / Cover Assy Side (R) / Cover Assy Side (L) / Cover Assy Front / Frame Assy Rear / Plate Front (stuck). (See 3.3.1)
- (2) Remove Space Motor. (See 3.3.15)
- (3) Remove Printing Head. (See 3.3.18)
- (4) Remove Idle Pulley (1) from Idle Pulley Bracket, then remove Space Belt (2).
- (5) Unscrew (5) screw and pull out Connector Guide (3), unscrew the screw (4) and remove Space Belt (2).
- (6) For installation, reverse the removal procedure.

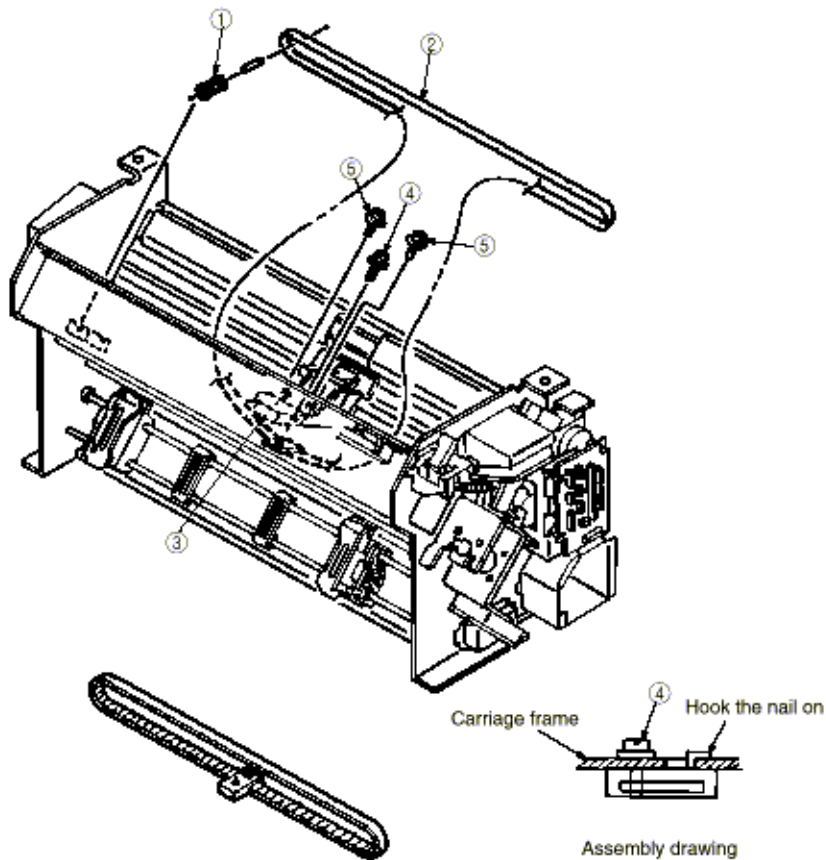

3.3.27 AG Sensor Frame / Start Searching Sensor

(1) Remove Cover Assy Access / Cover Assy Side (R) / Cover Assy Side (L) / Cover Assy Front / Frame Assy Rear / Plate Front (stuck). (See 3.3.1)

(2) Unscrew 2 screws (1) and remove Rear Plate (2).

(3) Unscrew 2 screws (3) and remove AG Sensor Cover (4).

(4) Unscrew 2 screws (5), unplug the connector (6) and remove AG Sensor Frame (7).

(5) Unscrew the screw (8) and release the latch, then remove Start Searching Sensor Lever Assy (9) and Start Searching Sensor Cord (10) together.

(6) Unscrew the screw (11) and unplug the connector (12) from I/F Board (CN9), then unplug Start Searching Sensor Cord (10).

(7) For installation, reverse the removal procedure.

(Note on Installation)

1. In assembling AG sensor frame (7), it should be pulled in the direction of arrow shown in the figure.

2. After assembling the AG sensor frame (7), check the AG plate gap as stated in Section 2 of Chapter 4 ADJUSTMENTS and execute the auto gap correction as stated in Section 3.

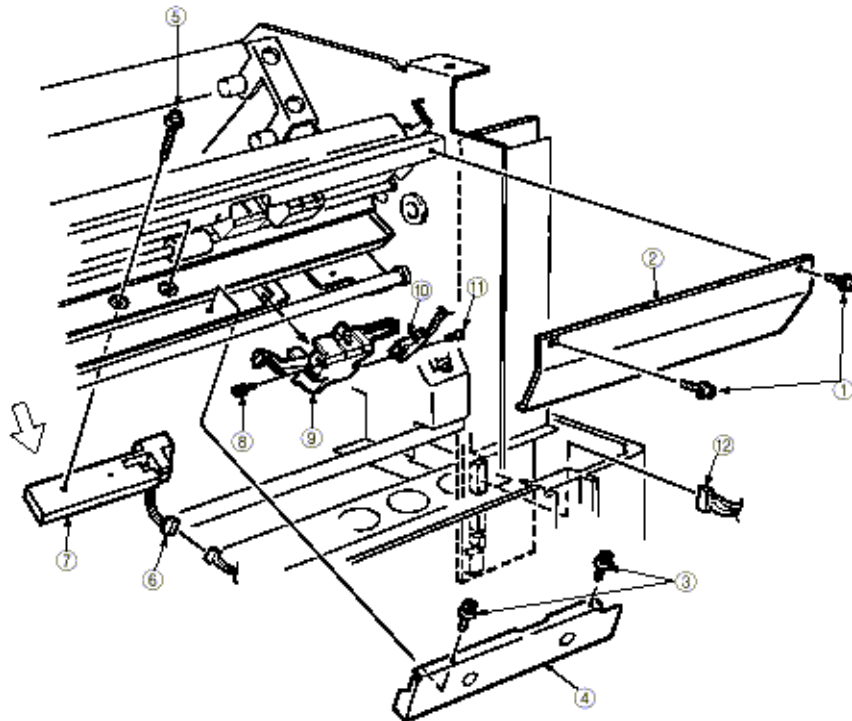

Copyright 1998, Okidata, Division of OKI America, Inc. All rights reserved. See the OKIDATA Business Partner Exchange (BPX) for any updates to this material. (<http://bpx.okidata.com>)

3.3.28 Paper Jam Sensor Assy / Bail PE Sensor Assy

- (1) Remove Cover Assy Access / Cover Assy Side (R) / Cover Assy Side (L) / Cover Assy Front / Frame Assy Rear / Plate Front (stuck). (See 3.3.1)
- (2) Unscrew the screw (1) and release the latch, then remove Paper Jam Sensor Assy (2).
- (3) Unscrew the screw (3) and release the latch, then remove Bail PE Sensor Assy (4).
- (4) Unplug the connector (5) from I/F Board (CN3).
- (5) Unscrew 2 screws (6), (7) and remove Paper Jam Sensor (8).
- (6) For installation, reverse the removal procedure.

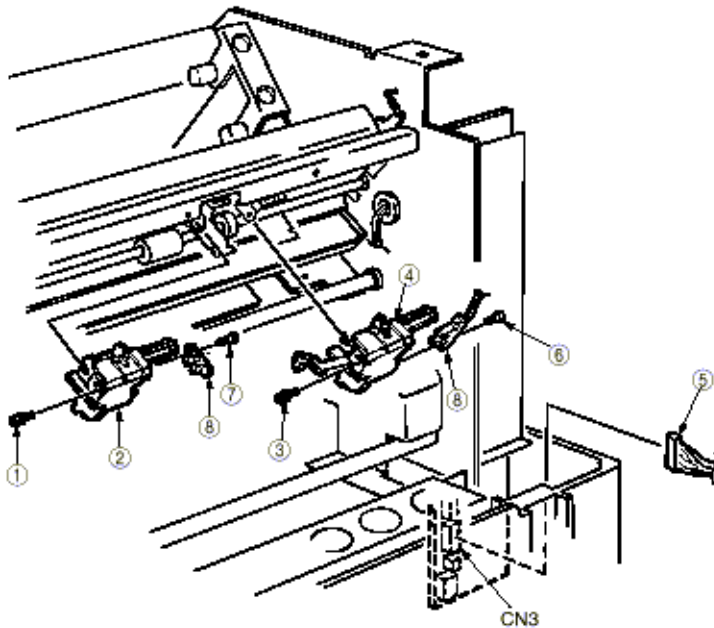



3.3.29 Sprocket Assy (L) (R) (Front Tractor)

- (1) Remove Cover Assy Access / Cover Assy Side (R) / Cover Assy Side (L) / Cover Assy Front / Frame Assy Rear / Plate Front (stuck). (See 3.3.1)
- (2) Remove Printer Unit. (See 3.3.2)
- (3) Remove Space Motor Fans. (See 3.3.21)
- (4) Remove 2 Sheet Guides (1).
- (5) Unplug the connector (3) from I/F Board (PHA Printed Board) (CN5) (2).
- (6) Release cords at cord clamps and remove the Snap Band.
- (7) Release the claw to remove Front Tractor Drive Gear (4).
- (8) Pull out Front Tractor Drive Shaft (5) to the right.
- (9) Unscrew 2 screws (6) and remove Front Lock Shaft (7), Sprocket Assys (L) (8) and (R) (9) together.
- (10) Release Lock Lever (10) and pull out Sprocket Assys (L) (8) and (R) (9) from Front Lock Shaft (7).
- (11) For installation, reverse the removal procedure.

(Note on Installation)

1. Adjust sprocket pin phases of Sprocket Assys (L) (8) and (R) (9), before inserting Front Tractor Drive Shaft (5) into them.

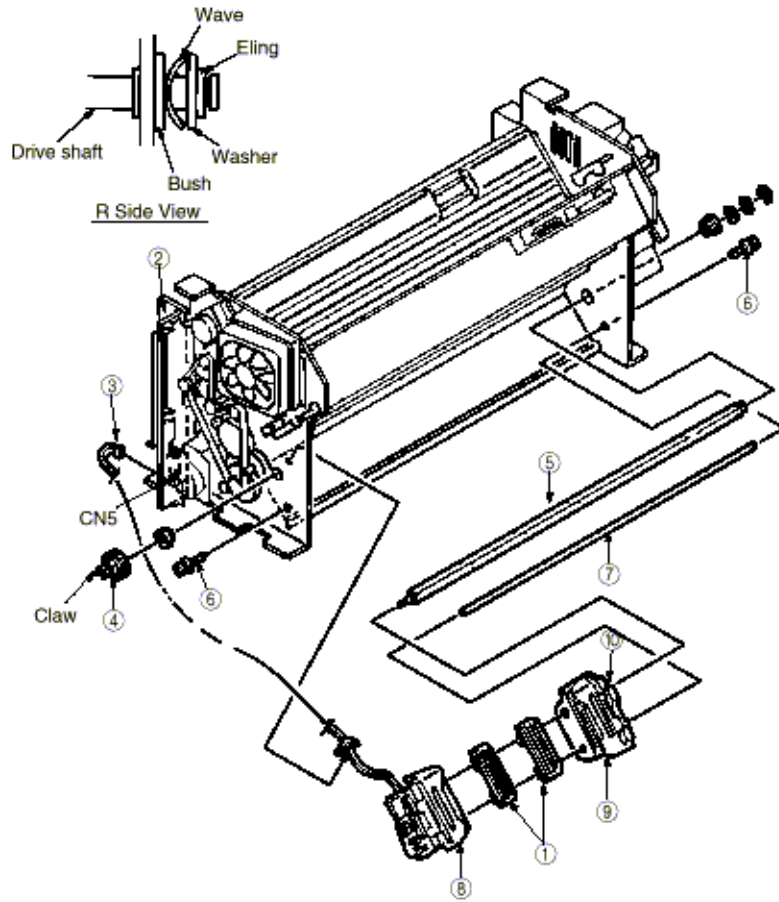

Copyright 1998, Okidata, Division of OKI America, Inc. All rights reserved. See the OKIDATA Business Partner Exchange (BPX) for any updates to this material. (<http://bpx.okidata.com>)



Service Guide for PM4410

Chapter 3 Disassembly

3.3.30 Sheet Feeder Assy (L) Rear / Sheet Feeder Assy (R) Rear

- (1) Remove Cover Assy Access / Cover Assy Side (R) / Cover Assy Side (L) / Cover Assy Front / Frame Assy Rear / Plate Front (stuck). (See 3.3.1)
- (2) Remove Printer Unit. (See 3.3.2)
- (3) Remove PG Cooling Fan. (See 3.3.5)
- (4) Remove Mini Pitch Belt. (See 3.3.9)
- (5) Remove I/F Board (PHA Printed Board). (See 3.3.6)
- (6) Remove Center Guide Lower (1).
- (7) Open the clamp of Drive Gear (2) to the arrow direction and remove the gear, then pull out Rear Tractor Drive Shaft (3).
- (8) Open the clamp of Rear Tractor Drive Gear (4) to the arrow direction and remove the gear, then pull out Rear Tractor Drive Shaft (5). At this time, Center Guide Upper (6) and Friction Piece (7) come off together.
- (9) Remove 2 Snap Bands (10) fastening Micro Switch Connecting Cord (9) on Sheet Feeder Assy (L) Rear (8), from Main Frame Assy (11). Then release the cords from the clamps on the cord route.
- (10) Unscrew 2 screws (12) on the right and left then remove Lock Shaft (14) with Sheet Feeder Assy (L) Rear (8) and Sheet Feeder Assy Rear (R) (13) on.
- (11) Release Lock Lever (15) and remove Sheet Feeder Assy (L) Rear (8) and Sheet Feeder Assy Rear (R) (13) from Lock Shaft (14).
- (12) For installation, reverse the removal procedure.

(Note on Installation)

1. Mount Sheet Feeder Assy (L) Rear (8) between 2 protrusions B on Main Frame Assy (11).
2. Mount Rear Tractor Drive Shafts (3) and (5) as follows:
 - (a) Adjust the position of Sprocket Wheel (14) protrusion at right and left pin tractors to that of Rear Tractor Drive Gear (4) hole, then insert Rear Tractor Drive Shaft (5).
 - (b) Adjust the position of Pin Wheel (16) protrusion at right and left pin tractors then insert Rear Tractor Drive Shaft (3).
 - (c) Adjust the position of Pin Wheel (16) protrusion to that of Drive Gear B (2) hole, align the holes at Rear Tractor Drive Gear (4) and at Drive Gear B (2) then mount Drive Gear B (2) on Rear Tractor Drive Shaft (3).
3. Give friction to Friction Piece (7) with a screwdriver turned 45 degrees, after inserting it into Rear Tractor Drive Shaft (5). Slow moving of Center Guide Upper (6) to the right/left means the right installation, and smooth one means the false installation.

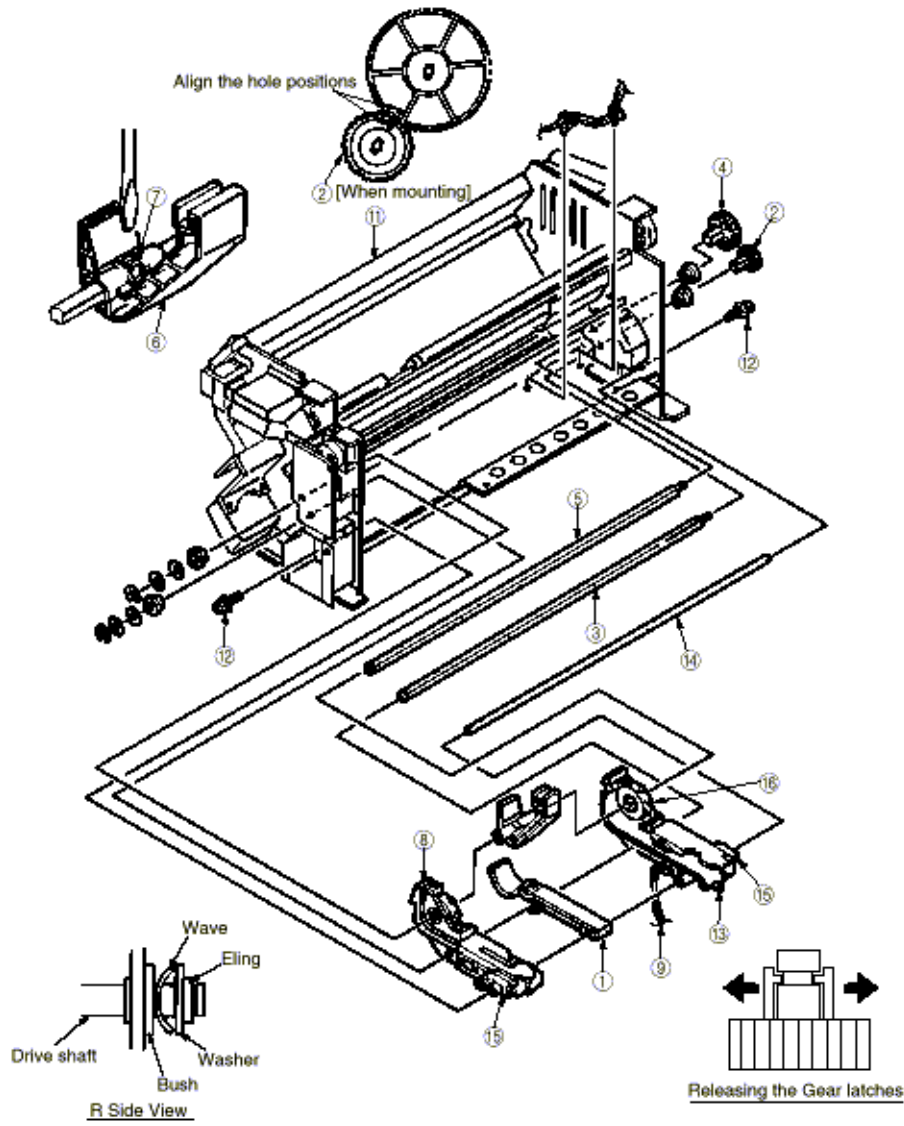

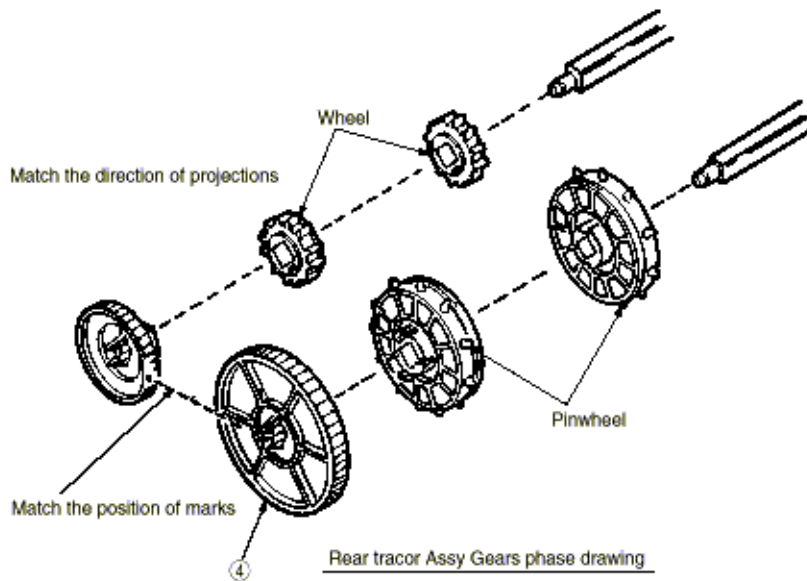

1. Matching the phase of pin tractors

- a. Match the direction of pin wheel projections on right/left pin tractor to that of mark on the (2) (rear tractor drive gear)
- b. Match the direction of wheel projections on right/left pin tractor to that of mark on (4) (drive gear B), and install (2) (drive gear B) to 5 3 (rear drive shaft of the rear tractor Assy) at a position where the directions of marks on (4) (drive gear B) and 2 (rear tractor drive gear) match.

Open up the notch to 1mm and assemble it, positioning the notch as shown in figure.

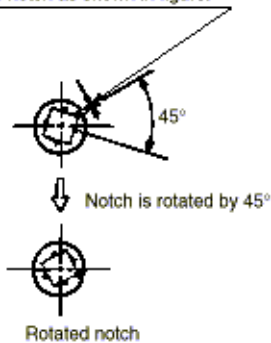

⑧ Assembling friction piece



3.3.31 Bail Assy

(1) Remove Cover Assy Access / Cover Assy Side (R) / Cover Assy Side (L) / Cover Assy Front / Frame Assy Rear / Plate Front (stuck). (See 3.3.1)

(2) Remove Mini Pitch Belt. (See 3.3.9)

(3) Remove Bail Motor Assy (See 3.3.11)

(4) Remove 2 Drive Pulleys (1).

(5) Unscrew 2 screws (2) and remove Bail Gear Assy (3).

(6) Release the claws at right/left Drive Gears B (4) then remove Drive Gears B (4), Wave Washers (5) and Flat Washers (6).

(7) Slide Bail Lift Lever (R) (9), Drive Gear B (7) and Drive Gear C (8) to the oblique upper direction and remove Bearing (Bail) (10).

(8) Remove 2 Bail Springs (11).

(9) Remove Screw Stud (12).

(10) Slide Bail Support Shaft (13) to the right then remove it from left Bearing (Bail) (14).

(11) Lift Bail Assy (15) to the oblique upper direction and pull it out to the left.

(12) For installation, reverse the removal procedure.

(Note on Installation)

1. The wave washers should be attached, paying attention to the direction of them.

2. The phase of bail lift lever (L), (R) should be matched in assembling them.

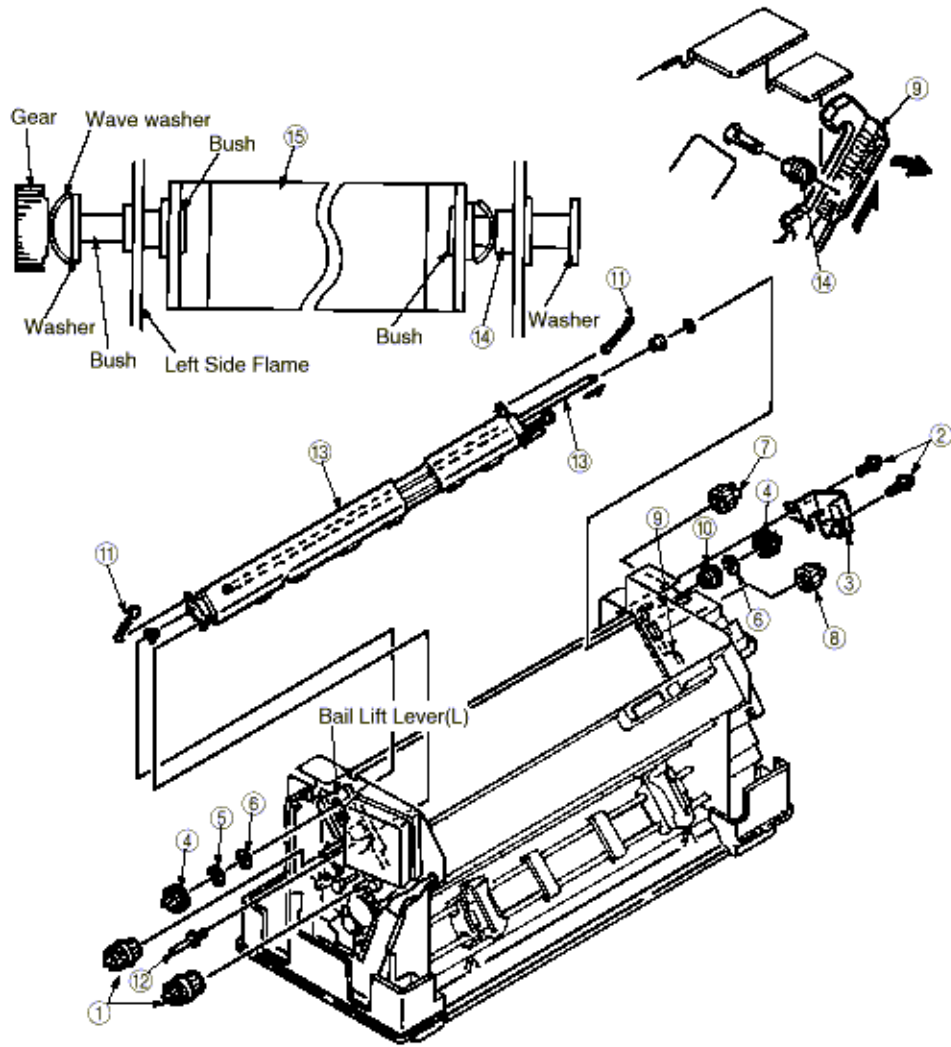

Copyright 1998, Okidata, Division of OKI America, Inc. All rights reserved. See the OKIDATA Business Partner Exchange (BPX) for any updates to this material. (<http://bpx.okidata.com>)

Adjustments

(1) Be sure to carry out this adjustment with the printer mechanism mounted on the lower cover.

(2) Be sure to carry out this adjustment operation on a level and highly rigid work table (flatness: less than 0.039 inch or 1 mm) so as to minimize adjustment error.

[Service Tool]

- No. 2-200 Philips screwdriver
- No. 2-200 screwdriver
- Feeler gauge
- 500 g rod tension gauge
- Calipers

Adjustment should be conducted after removing the Rear Cover (B) and setting the Dip Switch 1 on the board to "ON" (maintenance mode). (See Note 1 and 2)

Note 1: After the adjustment and lubrication have completed, set the all the dip switches to "OFF" (normal operation mode), and fix the Rear Cover (B) with the mounting screws.

Note 2: The local test printing except for the menu printing should be implemented with all the dip switches set to "OFF" (normal operation mode).

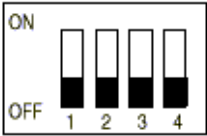
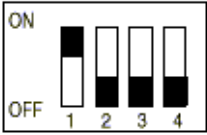
Item No.	Items	Standard Value	Illustration	Adjustment Method
1	Protector Gap Adjustment (1) Range Adjustment			<p>(1) Remove the Rear Cover (B) and set the Dip Switch 1 on the board to "ON" (maintenance mode).</p> <div style="text-align: center;"> <p>Temporary</p>  <p>Maintenance</p>  <p>DIP SW</p> </div> <p>(2) Close the access cover pressing Switches 7 and 1 starts the auto gap adjustment forward/backward up to the specified value.</p> <p>(3) When the platen stops</p>

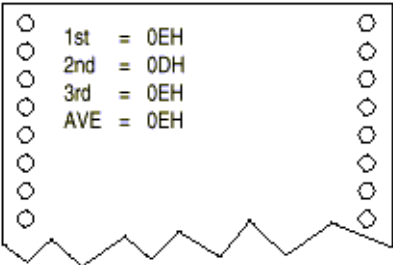
	<p>(2) Protector Gap</p>			<p>(1) insert the thickness ga protector frame to verify th between 0.12 and 0.16 m</p> <p>Notes: Although the adjus 0l12 to 0.16 mm, the confi from 0.09 to 0.2 mm.</p> <p>(2) If adjustment is require post with the Phillips screw frame to make the protect and 0.16 mm, then fix the</p> <p>Notes: a) The protector frame sh the platen, when measure points.</p>
<p>2</p>	<p>AG Plate Gap</p>	<p>$C=0.14\pm 0.02\text{mm}$</p>		<p>(1) Insert the thickness ga the AG plate to verify the ϵ and 0.16 mm.</p> <p>(2) If adjustment is require screws and adjust the ecc protector gap value C bet fix the AG plate.</p> <p>Notes: After this Adjustme should be conducted (See</p>
<p>3</p>	<p>Auto Gap Correction</p>  <p>1st = 0EH 2nd = 0DH 3rd = 0EH AVE = 0EH</p>		<p>(3) Turn on the printer while pressing Switches (12) and (13).</p> <p>(4) The auto gap correction has completed if "Av=" is printed.</p>	<p>(1) Set the continuous for at the printing valid positio</p> <p>(2) Turn on the printer, the pressing Switches (12) an correction. If the auto gap times and "Av= " printed, correction.</p> <p>(3) The auto correction va desirable. If any value othe plate gap should be adjus</p> <p>Notes: a) In the following cases, t implemented. i) After the gap adjustmen the AG plate; ii) After replacing the conti CG/PROGROM, EEPROM</p> <p>b) When the correction va and 18, "Warning" will be Press Switch 1 to reset thi</p> <p>c) The correction value "A If any value other than this the AG frame and the AG to the proper range as de: this correction.</p>

4	LF Motor Belt Tension	200 ~ 250gf		(1) Adjust the LF motor be assy, to produce the stanc deflected 1.5 mm at the m drive pulley B.
5	Slice Level Setting-paper Width Sensor			(1) Install the ribbon casse (2) Turn on the printer whi [11] at the operation panel correction mode - paper w "COMPLETE" is indicated be closed during this proc
6	Slice Level Setting-Paper Width Sensor			Notes: In the following cases, this implemented: 1) After replacing the Con ROM replacement). (1) Set the continuous for at the front tractor and als (2) Turn on the printer whi [13]. (This starts the paper correction mode). Confirm paper feeding/pai and then "COMPLETE" is Notes: In the following cases, the implemented. 1) After replacing the Con ROM replacement).
7	Auto Gap Motor Assy Backlash	J-0.1 mm		(1) Verify the backlash is (and the adjusting cam. (2) If adjustment is require fixing the auto gap assy, a between the idle gear and
8	Bail Gear Assy Backlash	K-0.2 mm		(1) Verify the backlash is (and the drive gear B, and idle gear C. (2) If adjustment is require fixing the bail gear assy, a between the idle gear A ai between the idle gear B ai

<p>9</p>	<p>Installing the printhead</p>		<p>(1) In installing the printhead impinging plate on the carriage</p> <p>Notes:</p> <p>The printhead should be in the correct position. (prevent protecto</p> <p>(2) How to tighten screws</p> <p>a. Lightly tighten the right printhead against the carriage</p> <p>b. In tightening the screws tighten the left screw after pushing the head against</p> <p>Notes 1:</p> <p>To prevent the float of head</p> <p>Notes 2:</p> <p>Tightening the screws in the direction of left arrow and</p> <p>(3) Adjust the backlash of carriage can meet the center of the</p>
<p>10</p>	<p>Alignment of horizontal printing</p>		<p>(1) Set in continuous paper (sheet) onto the printable paper</p> <p>(2) Press [5] switch to go to the display "Set-Up". Next, press [6] (The printer starts Registration)</p> <p>Open the access cover to check the progress and close it, and after pressing the ON-LINE</p> <p>Correct the printing alignment</p> <p>"Registration17". (Note 1)</p> <p>Note2) After printing, check the registration</p> <p>Note3) The reverse printing to the reference position by pressing [4] switch.</p> <p>(4) After completing the correction, store the corrected values (Note4)</p> <p>Note4) If the [6] switch is pressed, the values cannot be stored and return to the previous set values.</p> <p>Press [5] while holding [8] to complete the registration.</p>

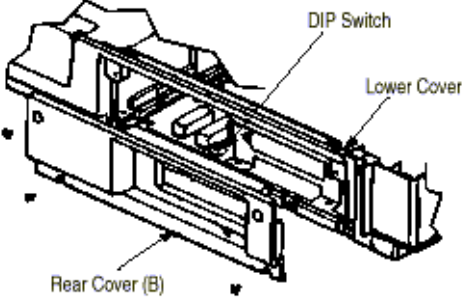
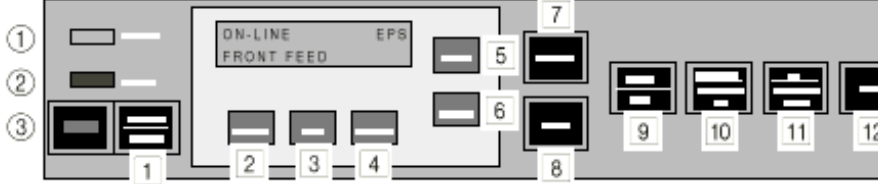
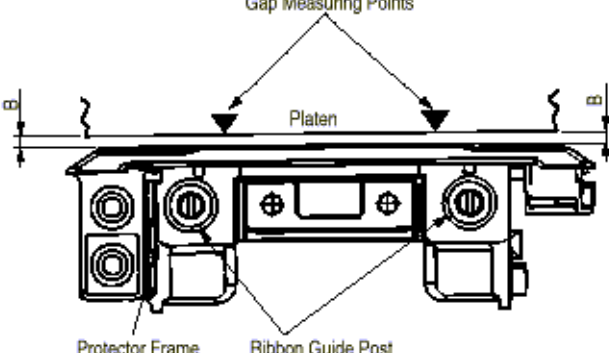
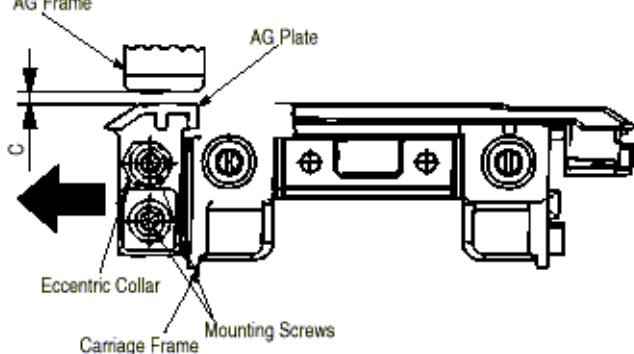
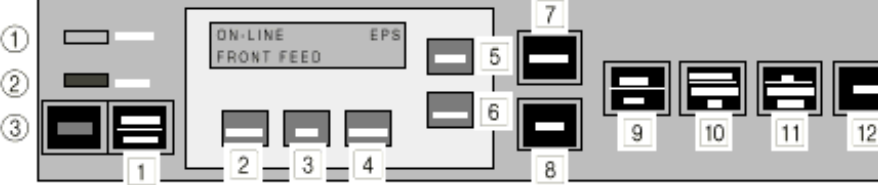
Item No.	Items	Graphics
1	Protector Gap Adjustment (1) Range Adjustment	
		
	(2) Protector Gap	
2	AG Plate Gap	
3	Auto Gap Correction	

<p>4</p>	<p>LF Motor Belt Tension</p>	
<p>7</p>	<p>Auto Gap Motor Assy</p>	
<p>8</p>	<p>Bail Gear Assy Backlash</p>	

9

Installing printhead

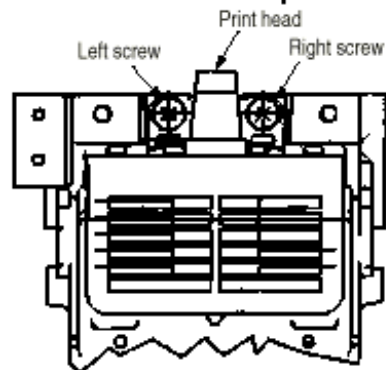
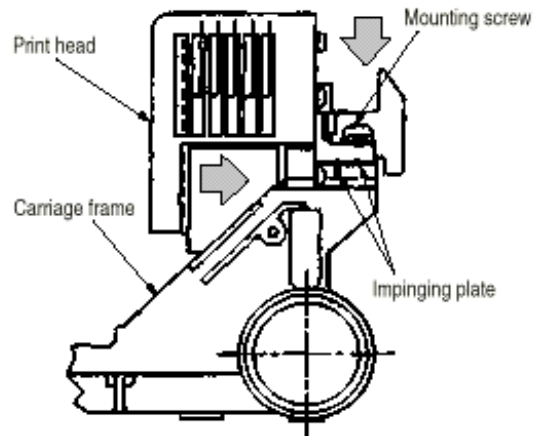

Install the print head so that the center of the print head meet that of protector.

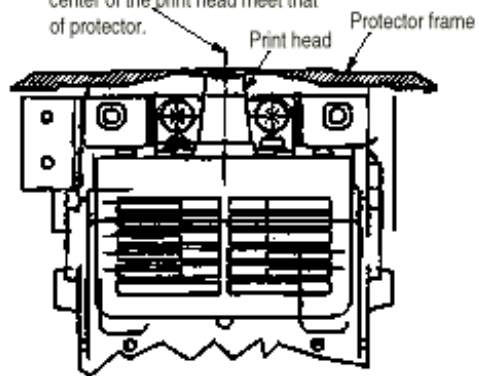

10

Alignment of horizontal printing

Number	Correction dot position of reverse printing
+5	Printing position is shifted by 0.25mm to right of the reference position.
+4	Printing position is shifted by 0.20mm to right of the reference position.
+3	Printing position is shifted by 0.15mm to right of the reference position.
+2	Printing position is shifted by 0.10mm to right of the reference position.
+1	Printing position is shifted by 0.05mm to right of the reference position.
0	Reference position
-1	Printing position is shifted by 0.05mm to left of the reference position.
-2	Printing position is shifted by 0.10mm to left of the reference position.
-3	Printing position is shifted by 0.15mm to left of the reference position.
-4	Printing position is shifted by 0.20mm to left of the reference position.
-5	Printing position is shifted by 0.25mm to left of the reference position.

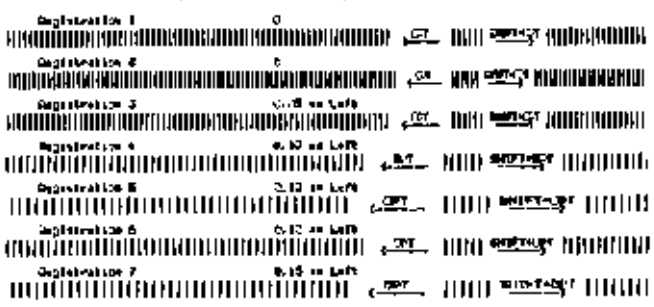



Service Guide for PM4410

Chapter 5 Maintenance

5.1 Cleaning

[Caution]

1. Be sure to turn OFF the AC POWER switch before cleaning. Remove the AC Power cord from the printer.
2. Avoid dust inside the printer mechanism when cleaning.
3. If a lubricated part has been cleaned, be sure to apply lubricating oil to that portion after cleaning.

(1) Cleaning time

When the equipment time has reached six months or 300 hours, whichever comes first.

(2) Cleaning tools

Dry cloth (soft cloth such as gauze), vacuum cleaner.

(3) Places to be cleaned

Table 5.1 lists the places to be cleaned:

Table 5.1

Place to be cleaned	Cleaning procedure
Main shaft and the vicinity	Remove paper waste and wipe off stain, dust, waste, etc.
Paper travel surface	
Ribbon guide and the vicinity	

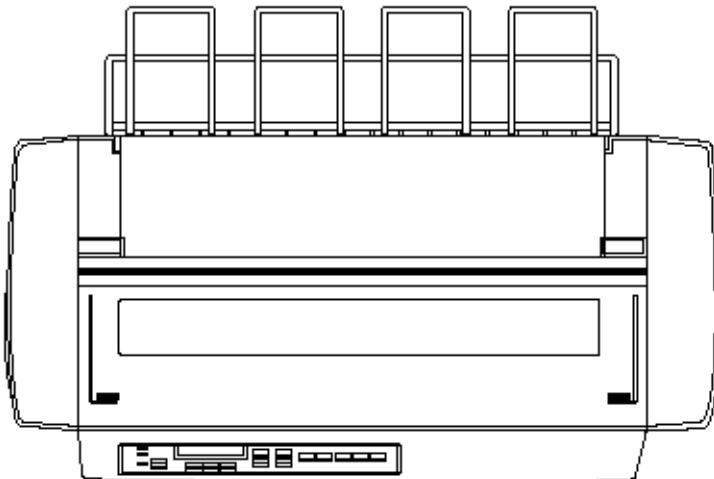



Service Guide for PM4410 Chapter 5 Maintenance

5.2 Lubrication

This printer is designed to be maintenance free and requires no lubrication during normal operation. However it is necessary to apply lubricant in case the printer is disassembled, reassembled, cleaned or parts have been changed.

(1) Cleaning time

Remarks:

- 1) Turn off the power before cleaning.
 - 2) Make sure that paper dust will not fall inside of the machine.
- Cleaning period:
6 months of operation or 300 hours of operation, whichever the earlier.

- Cleaning points:

Carriage shaft and surroundings	Remove paper and ribbon dust.
Paper path	Clean stains and dusts.
Paper End Sensor	Remove the dust on the Sensor
Paper Width Sensor	Remove the dust on the Sensor.
Ribbon Jam Sensor	Remove the dust on the Sensor.
Paper Out Sensor	Remove the dust on the Sensor.
Paper Jam Sensor	Remove the dust on the Sensor.

(2) Lubricant

- Pan motor oil (or equivalent): PM
- Albania grease (or equivalent): GEP

(3) Amount of lubricant

- Medium amount A : Apply three to four drops of oil, or 0.008 inch (0.2 mm) thick grease.
- Small amount B : Apply one drop of oil (0.006±0.002 g)

(4) Areas to Avoid

No.	Do not lubricate	Reason
1	Ink ribbon	To prevent blurring of print
2	Sensor	To prevent dust adhering
3	Platen (printing face)	To prevent stained paper
4	Feed roller (rubber face and resin face)	To prevent stained paper
5	Pitch belt	To prevent rubber degradation
6	Head cable	To prevent deterioration
7	Micro switch	To prevent stained paper
8	Pin tractor surface	To prevent contacts
9	Auto gap disc	To prevent dust adhering

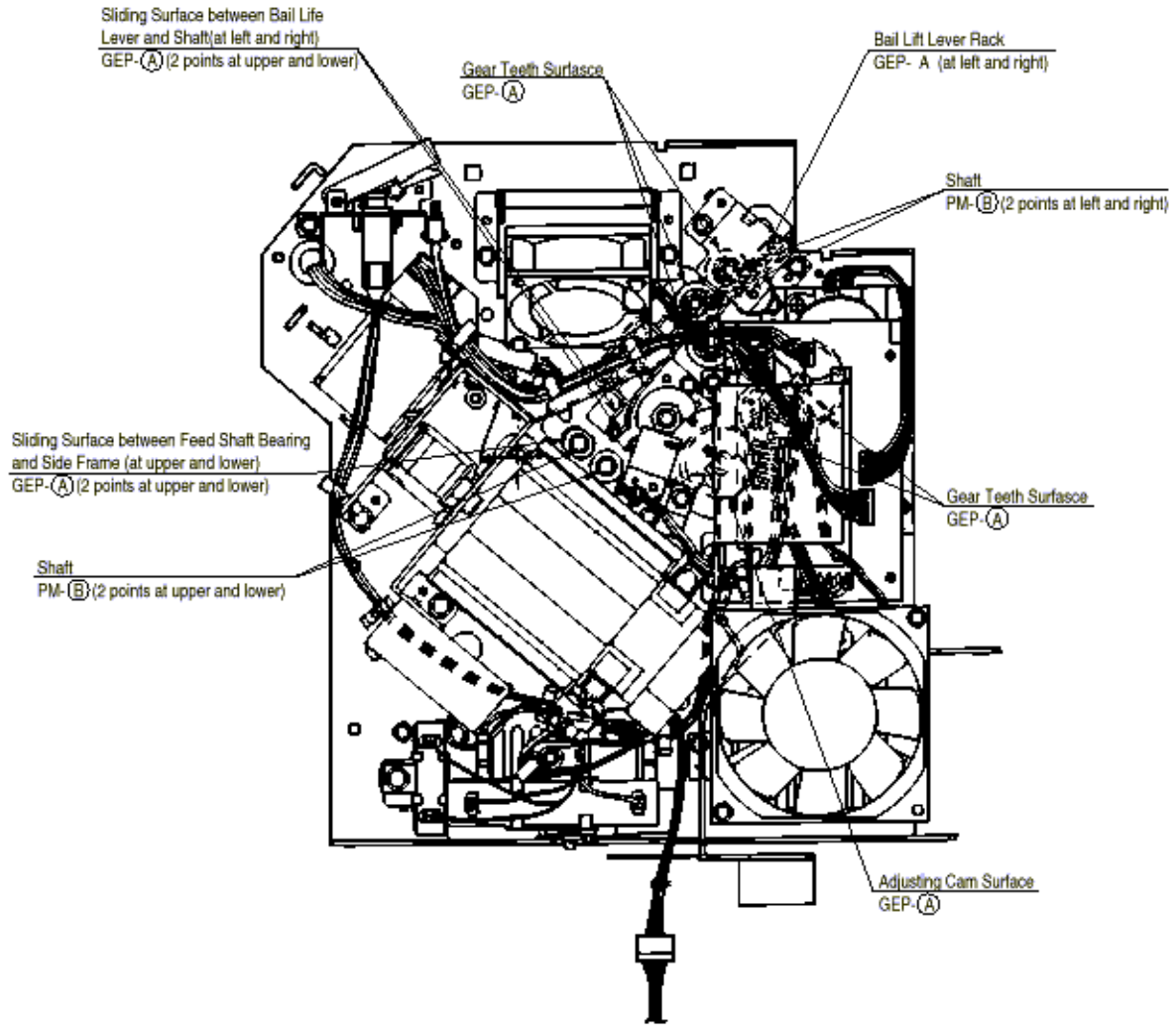

Right Side View

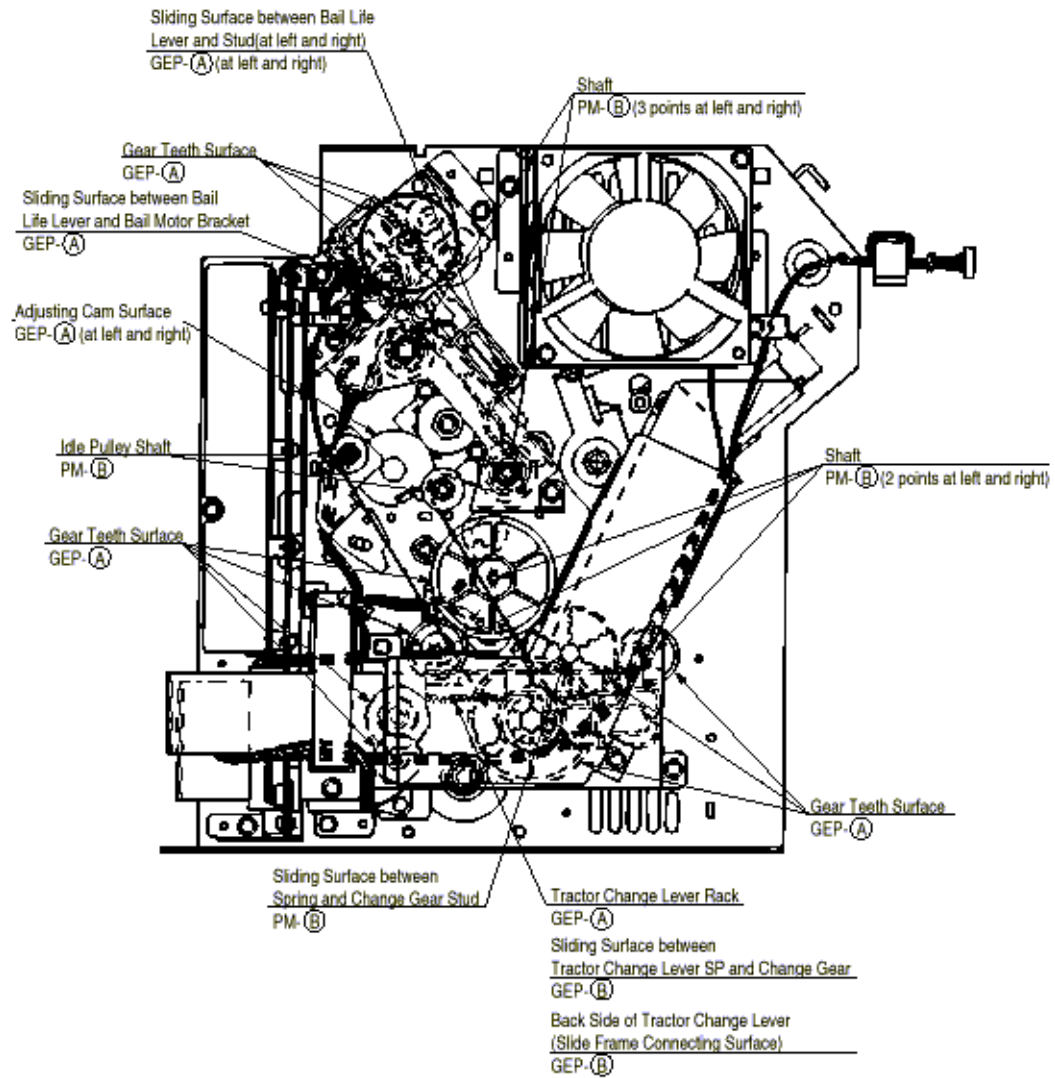

Left Side View

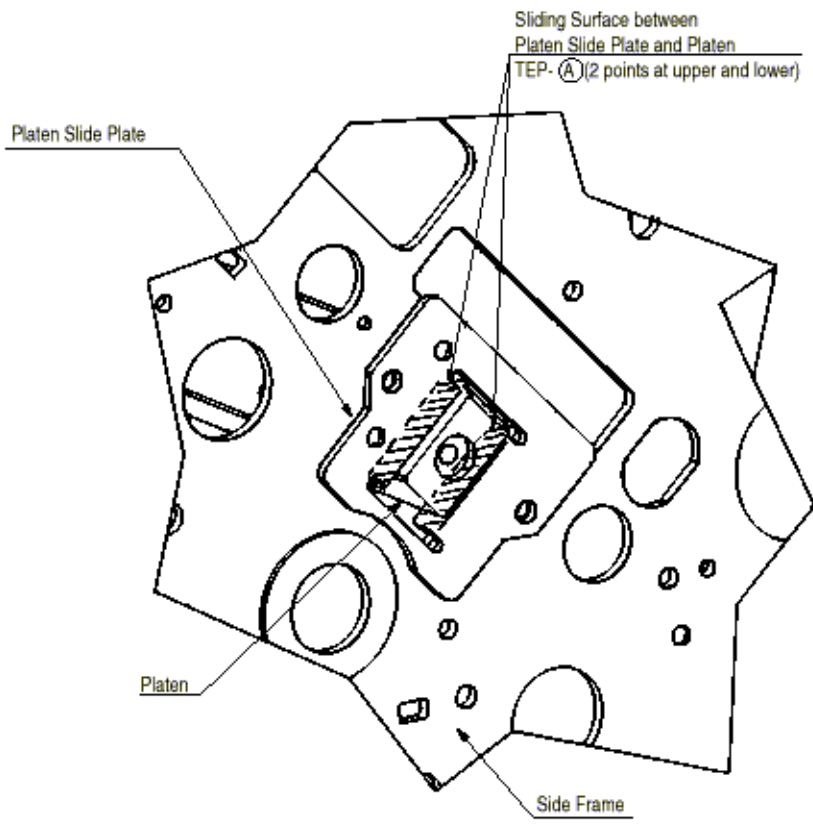

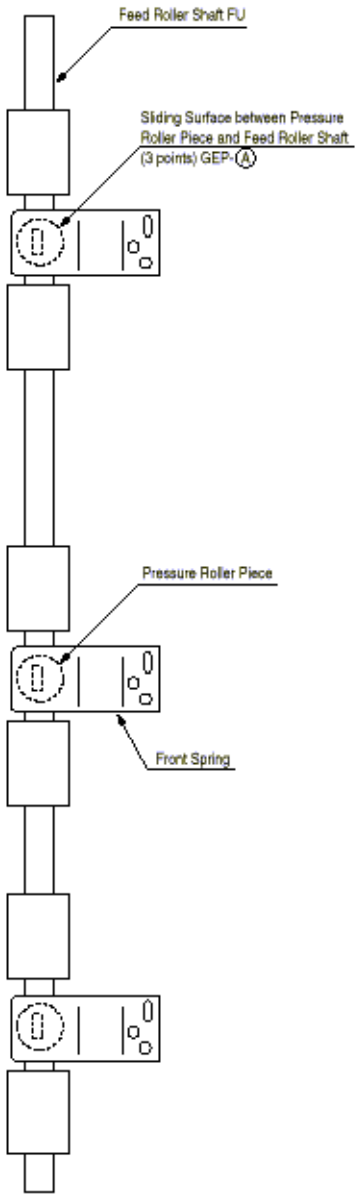

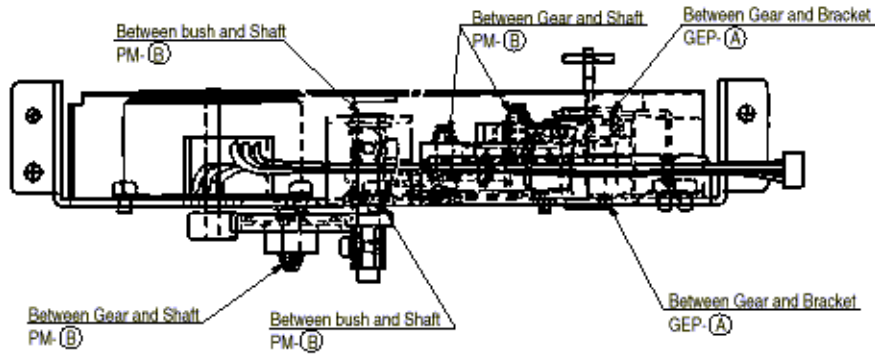
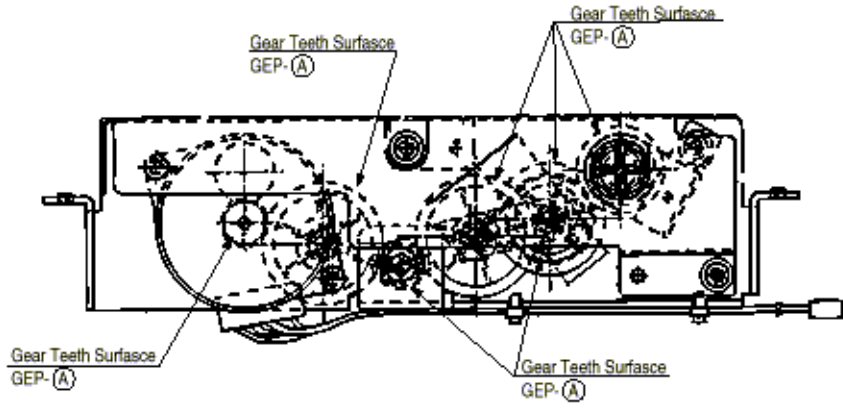

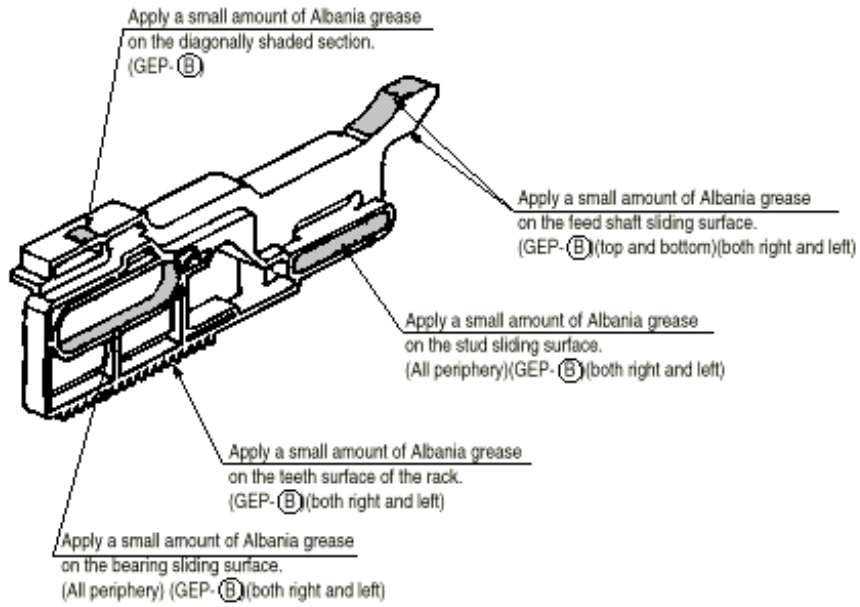

Bail lift lever oblique view

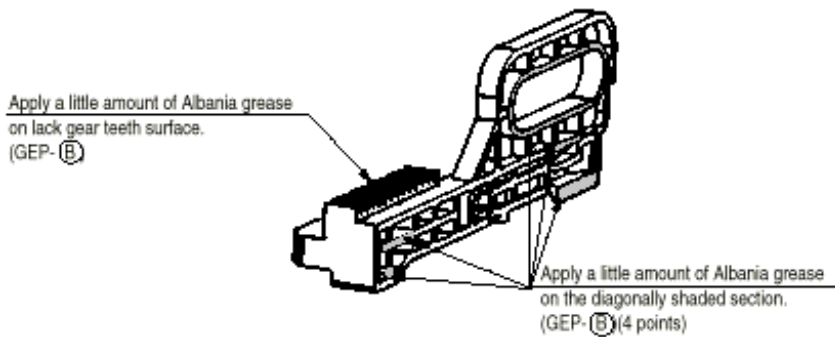

Tractor change lever Assy oblique view

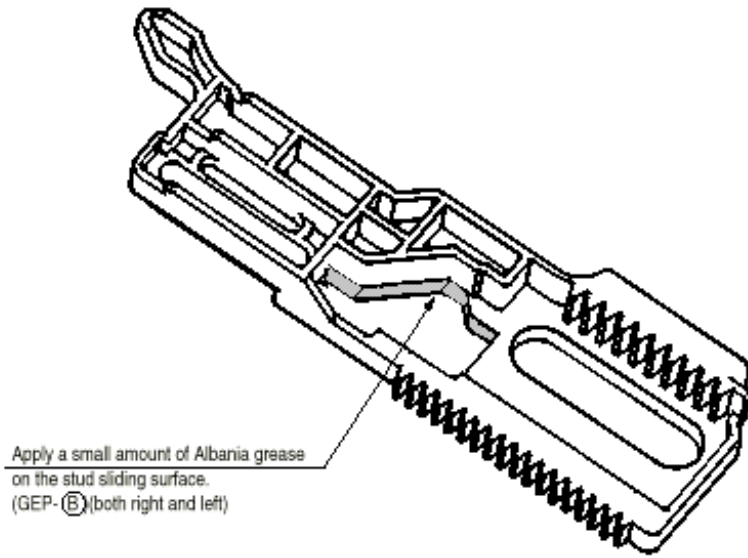

Copyright 1998, Okidata, Division of OKI America, Inc. All rights reserved. See the OKIDATA Business Partner Exchange (BPX) for any updates to this material. (<http://bpx.okidata.com>)



Service Guide for PM4410 Chapter 5 Maintenance

(28) Option Interface

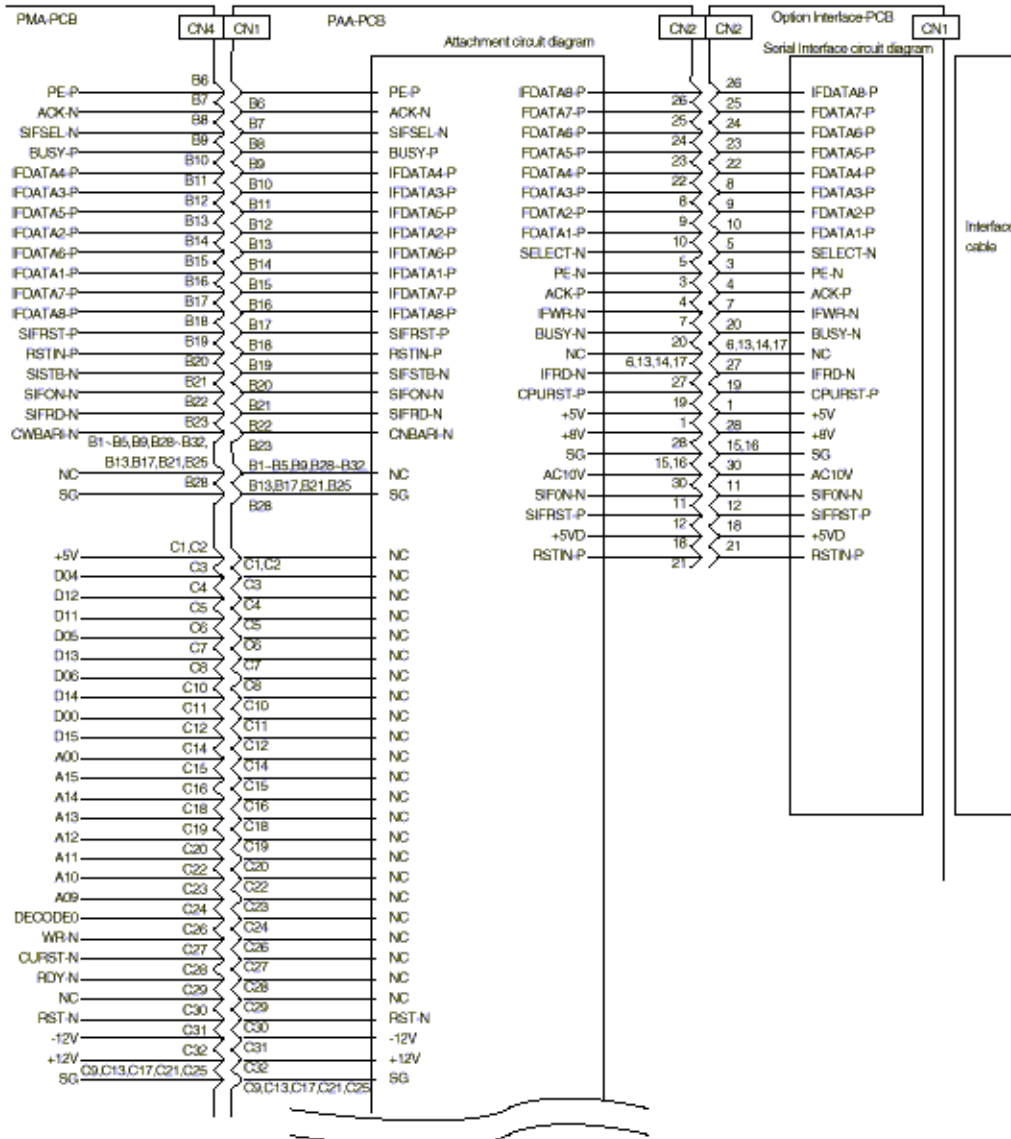

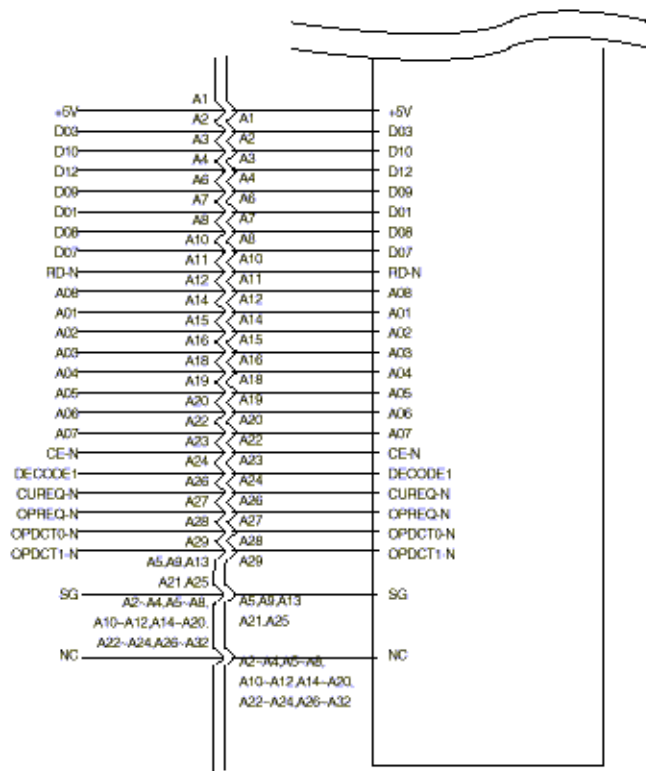

Copyright 1998, Okidata, Division of OKI America, Inc. All rights reserved. See the OKIDATA Business Partner Exchange (BPX) for any updates to this material. (<http://bpx.okidata.com>)



Service Guide for PM4410 Chapter 6 Maintenance

6.1 Items to Check Before Repair

- (1) Check the inspection items specified in the instruction manual.
- (2) Find out as many details of the trouble as possible from the customer.
- (3) Inspect in the conditions as close as possible to those at the time the trouble occurred.
- (4) Proceed with the repair as follows:

Check the trouble status according to Table 6.1 for the details of the trouble. Then, locate the trouble position according to the detailed flowchart.

- (5) Carry out a thorough test after the repair to check for correct functioning.



Service Guide for PM4410 Chapter 6 Maintenance

6.2 Troubleshooting Table

Table 6.1

Status	Details	Flowchart Item No.
Trouble upon power on	Power is not supplied	(1)
	No spacing operation	(2)
	Homing does not end normally	(3)
Trouble during printing	Wrong character, character omission or dot omission	(4)
	Ribbon feed trouble	(5)
	Line feed trouble	(6)
	Malfunction of switch on operation panel	(7)
	Data receiving failure	(8)
	Data is entered, but the paper does not feed	(9)
	The ALARM indicator on the printer is lit.	(10)
	The SELECT indicator on the printer is off.	(11)
	Paper jam while paper inset.	(12)
	Smearing / Missing dots	(13)
Faint or dark print.	(14)	



Service Guide for PM4410 Chapter 6 Maintenance

6.3 Lamp and LCD Display

(1) Printer mode display

Table 6.2 and Table 6.3

	PRINTER MODE	ALARM	SELECT	LCD	CONTENTS	REMED
Operation mode	ON LINE	OFF	ON	ON-LINE	Indicates that the printer is ready for receiving.	
	HEX DUMP	OFF	ON	HEXDUMP	Indicates that the printer is in the hex dump mode.	
	SELF TEST	OFF	OFF	SELF TEST	Indicates that the printer is in the self test mode.	
	MENU	OFF	OFF		Indicates that the printer is in the menu mode.	As for L message refer to List
Operator alarm	FRONT PAPER END	ON	OFF	FRONT PAPER END	Front form end.	
	REAR PAPER END	ON	OFF	REAR PAPER END	Rear form end.	
	EJECT JAM	ON	OFF	EJECT JAM	Paper Eject Jam.	
	LODE JAM	ON	OFF	LOAD JAM	Paper Load Jam.	
	PARK JAM	ON	OFF	PARK JAM	Paper Park Jam.	
	FEED JAM	ON	OFF	FEED JAM	Paper Feed Jam.	
	PAPER JAM	ON	OFF	PAPER JAM	Paper Jam.	
	RIBBON JAM	ON	OFF	RIBBON JAM	RIBBON FEED JAM.	
Operator alarm	PATH CHANGE JAM	ON	OFF	PATH CHANGE JAM	Paper jam due to path change.	
	PAPER RELEASE	OFF	OFF	PAPER RELEASE	Indicates that paper is released.	
	COVER OPEN	ON	OFF	COVER OPEN	Indicates that the Access Cover is opened.	
	DATA REMAIN	ON	OFF	DATA REMAIN	Indicates that Cover Open Alarm occurred when data remained inside (Cover Open during space-system operation), then Cover was closed.	
Fault alarm					For details see paragraph (2) fault alarm display.	

Table 6.4

Error Category	LCD	Comments	Remedies
RAM ALARM	D-RAM	D-RAM Error	
ROM ALARM	S-RAM	S-RAM Error	
	PROGRAM-ROM	Program-ROM Error	
	CG-ROM	CG-ROM Error	
	EEPROM	EEPROM Error	
PROGRAM ALARM	WDT	Watch Dog Time Error	
	INVALID IPT	Invalid Input Error	
ENGINE ALARM	SPACING	Spacing Error	Refer to flow chart (2)
	HOMING	Homing Error	Refer to flow chart (3)
	FUSE	Fuse Breakdown	Refer to flow chart (1)
	HEAD THERMISTER	Head Thermister Failure	
	AUTO GAP	Auto-Gap Error	
	PATH CHANGE	Path-Change Error	
	CENTERING	Centering Error	
	POWER FAN	Power Fan Failure	
	HEAD 1 FAN	Head Fan 1 Failure	
	HEAD 2 FAN	Head Fan 2 Failure	
	SPACE FAN	Space Motor Fan Failure	
	NHDC LSI	NHDC LSI Error	
	MAIN LSI	Main LSI Error	
	BAIL	Bail Motor Error	
ENGINE ALARM	RIBBON	Ribbon Motor Error	Refer to flow chart (5)

	OPTICAL SENSOR	Paper Width Sensor Error	
OPERATION PANEL ALARM	LCDTIME OUT	LCD Time-out Error	
	FLASH CHIP	Flash Memory Chip Error (Except for Fujitsu-and-AMD-made chips)	
FLASH MEMORY ALARM	FLASH UNLOAD	Flash Memory Unloading Error	
	FLASH HASH	Flash Memory HASH Error	
	FLASH MEMORY	Flash Memory Polling Error	
	FLASH COMMAND	Flash Memory Command Received	
MUPIS ALARM	OKI HSP CONNECT	HSP Connection Error	
OPTION ALARM	OPT CARD ROM	ML300's IF Card ROM Error	
	OPT CARD RAM	ML300's IF Card RAM Error	
	OPT CARD CONNECT	ML300's IF Card Connection Error	

Copyright 1998, Okidata, Division of OKI America, Inc. All rights reserved. See the OKIDATA Business Partner Exchange (BPX) for any updates to this material. (<http://bpx.okidata.com>)

Service Guide for PM4410 Chapter 6 Maintenance

6.4 Part Layout

(1) Board

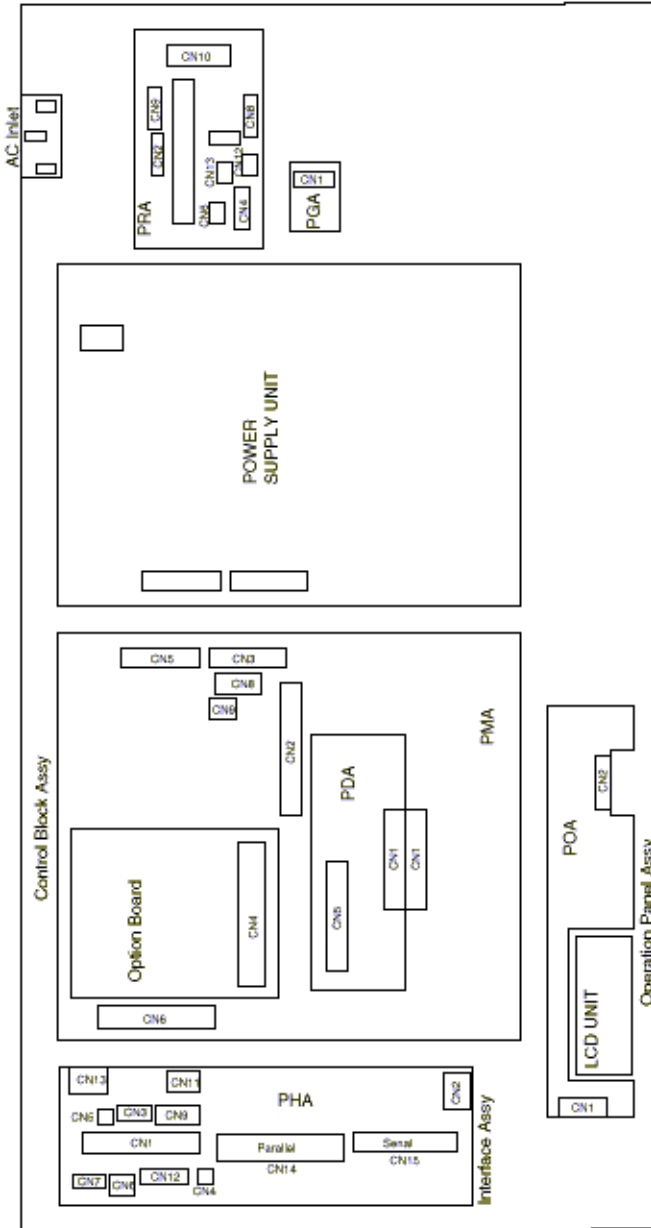

(2) Other

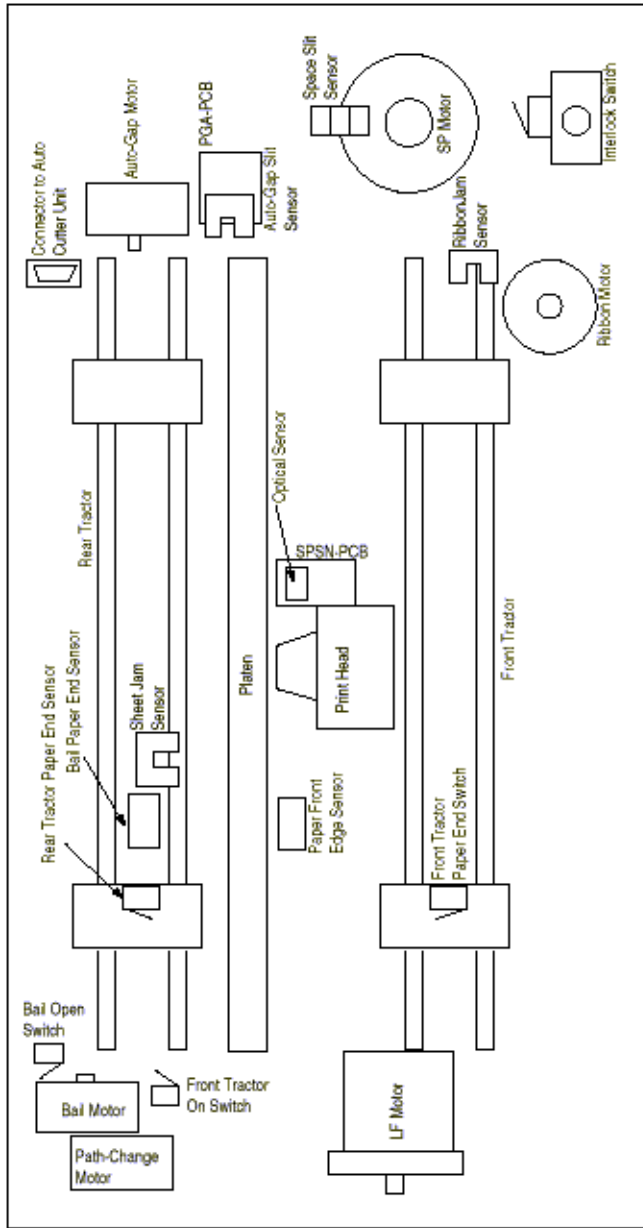

Copyright 1998, Okidata, Division of OKI America, Inc. All rights reserved. See the OKIDATA Business Partner Exchange (BPX) for any updates to this material. (<http://bpx.okidata.com>)



6.5 Connection

- (1) Printhead
- (2) Line feed motor
- (3) Space motor
- (4) Ribbon motor
- (5) Path-change motor
- (6) Auto-gap motor
- (7) Bail motor
- (8) Space Fan1
- (9) Space Fan2
- (10) Head Fan1
- (11) Head Fan2
- (12) Power Fan
- (13) Space slit sensor
- (14) Auto-gap slit sensor
- (15) Cover Open Switch / Ribbon Jam Sensor
- (16) Optical Sensor
- (17) Sheet Top Locating Sensor / Auto Gap Core
- (18) Paper Jam Sensor / Bail Paper End Sensor
- (19) Bail Open Switch / Front Tractor on Switch
- (20) Front Tractor Paper End Switch
- (21) Rear Tractor Paper End Switch
- (22) Power Supply Unit
- (23) Operation Panel
- (24) Standard Interface
- (25) Short Plug
- (26) others
- (27) MUPIS Interface (Option)
- (28) Option Interface

(29) Continuous-form Paper Cutter (Option)

Copyright 1998, Okidata, Division of OKI America, Inc. All rights reserved. See the OKIDATA Business Partner Exchange (BPX) for any updates to this material. (<http://bpx.okidata.com>)



Service Guide for PM4410 Chapter 6 Maintenance

(1) Printhead

Resistance of each coil should be about 5.8 Ohms

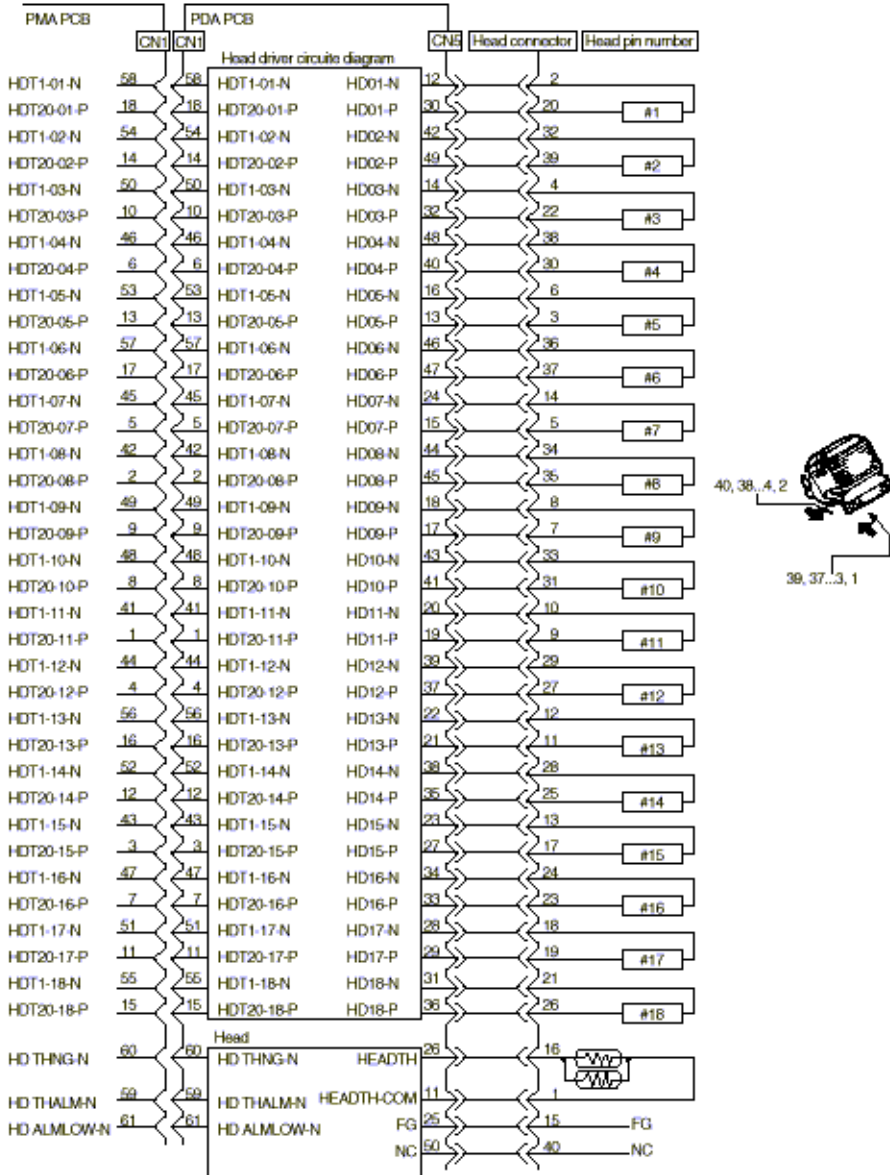

Service Guide for PM4410 Chapter 6 Maintenance

(2) Line feed motor

Resistance of each coil should be about 4.2 Ohms

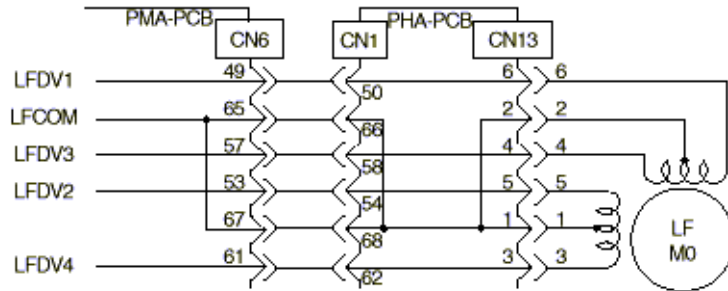

Copyright 1998, Okidata, Division of OKI America, Inc. All rights reserved. See the OKIDATA Business Partner Exchange (BPX) for any updates to this material. (<http://bpx.okidata.com>)

Service Guide for PM4410 Chapter 6 Maintenance

(3) Space motor

Resistance of motor should be about 1.08 Ohms

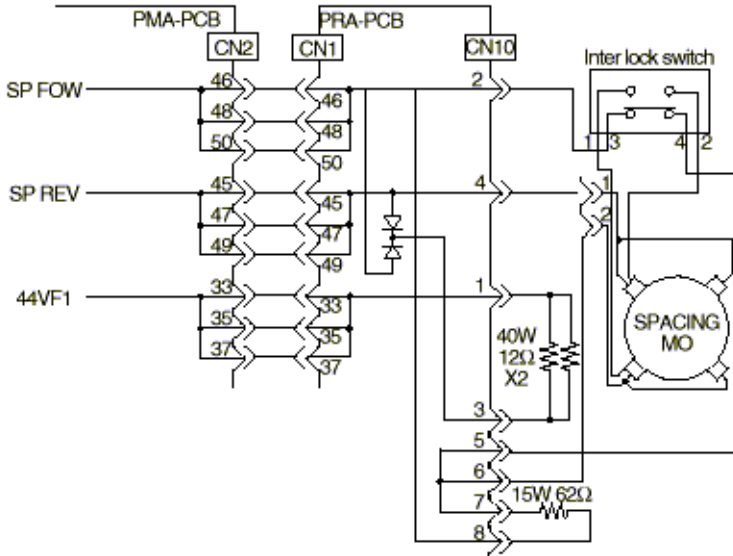

Service Guide for PM4410 Chapter 6 Maintenance

(4) Ribbon motor

Resistance of each coil should be about 155 Ohms

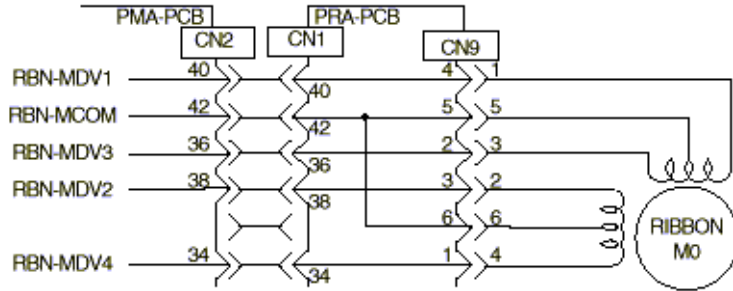

Service Guide for PM4410 Chapter 6 Maintenance

(5) Path-change motor

Resistance of each coil should be about 90 Ohms

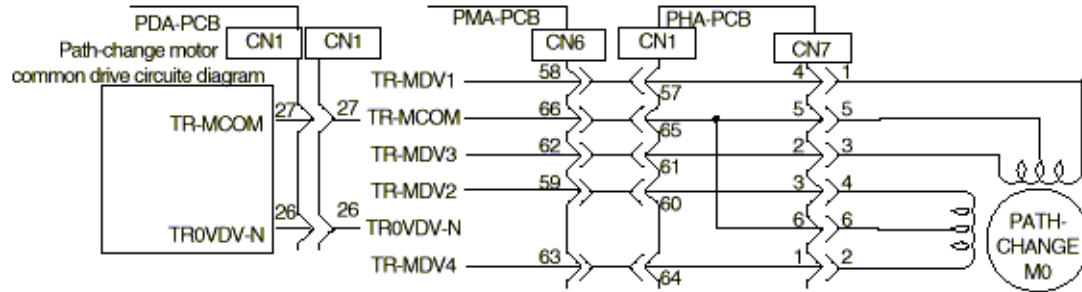

Service Guide for PM4410 Chapter 6 Maintenance

(6) Auto-gap motor

Resistance of each coil should be about 90 Ohms

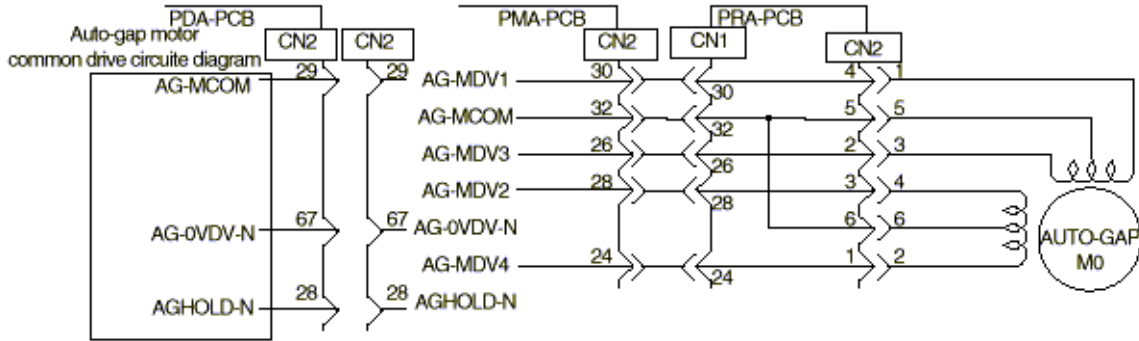

Service Guide for PM4410 Chapter 6 Maintenance

(7) Bail motor

Resistance of each coil should be about 90 Ohms

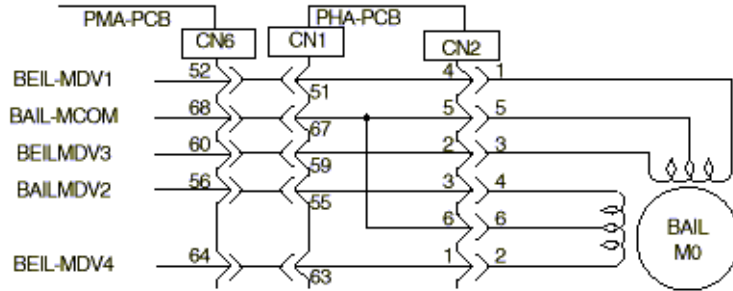

Copyright 1998, Okidata, Division of OKI America, Inc. All rights reserved. See the OKIDATA Business Partner Exchange (BPX) for any updates to this material. (<http://bpx.okidata.com>)

Service Guide for PM4410 Chapter 6 Maintenance

(8) Space Fan1

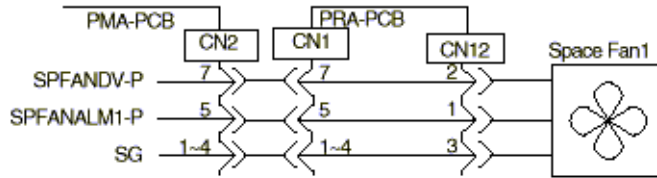

Copyright 1998, Okidata, Division of OKI America, Inc. All rights reserved. See the OKIDATA Business Partner Exchange (BPX) for any updates to this material. (<http://bpx.okidata.com>)

(9) Space Fan2

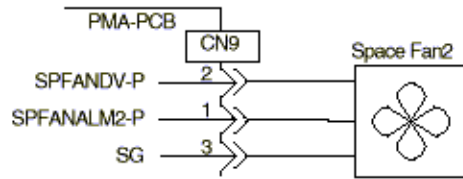

(10) Head Fan1

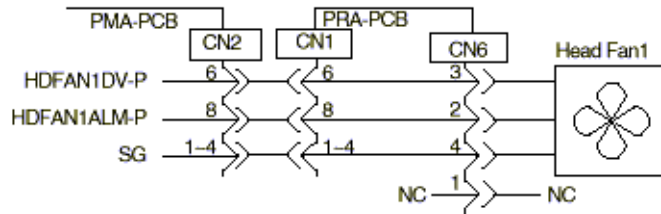

Copyright 1998, Okidata, Division of OKI America, Inc. All rights reserved. See the OKIDATA Business Partner Exchange (BPX) for any updates to this material. (<http://bpx.okidata.com>)

Service Guide for PM4410 Chapter 6 Maintenance

(11) Head Fan2

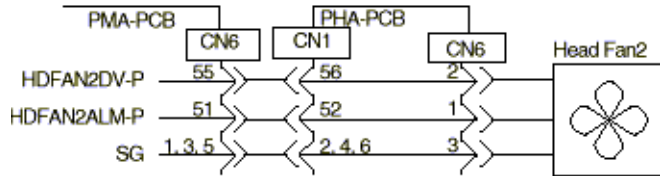

Copyright 1998, Okidata, Division of OKI America, Inc. All rights reserved. See the OKIDATA Business Partner Exchange (BPX) for any updates to this material. (<http://bpx.okidata.com>)

Service Guide for PM4410 Chapter 6 Maintenance

(12) Power Fan

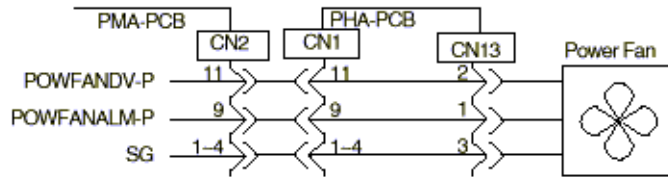

Copyright 1998, Okidata, Division of OKI America, Inc. All rights reserved. See the OKIDATA Business Partner Exchange (BPX) for any updates to this material. (<http://bpx.okidata.com>)

Service Guide for PM4410 Chapter 6 Maintenance

(13) Space slit sensor

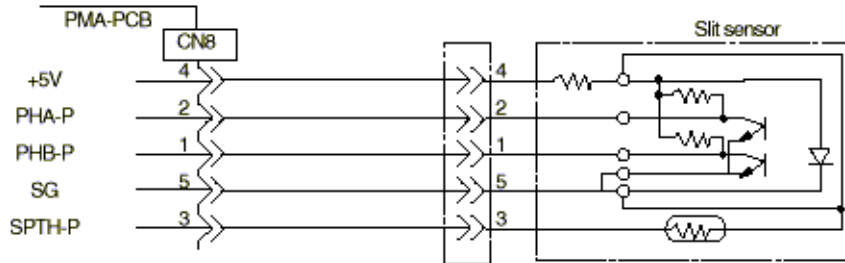



Service Guide for PM4410 Chapter 6 Maintenance

(14) Auto-gap sensor

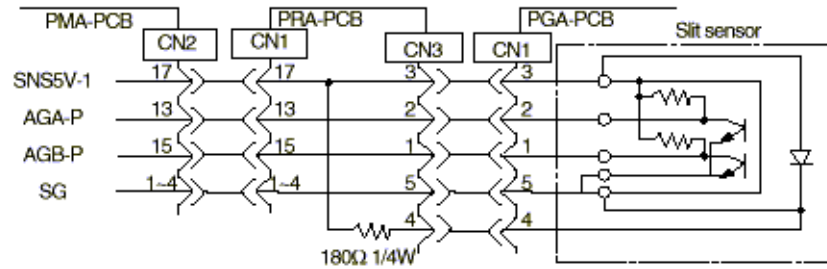

Copyright 1998, Okidata, Division of OKI America, Inc. All rights reserved. See the OKIDATA Business Partner Exchange (BPX) for any updates to this material. (<http://bpx.okidata.com>)

Service Guide for PM4410 Chapter 6 Maintenance

(15) Cover Open Switch / Ribbon Jam Sensor

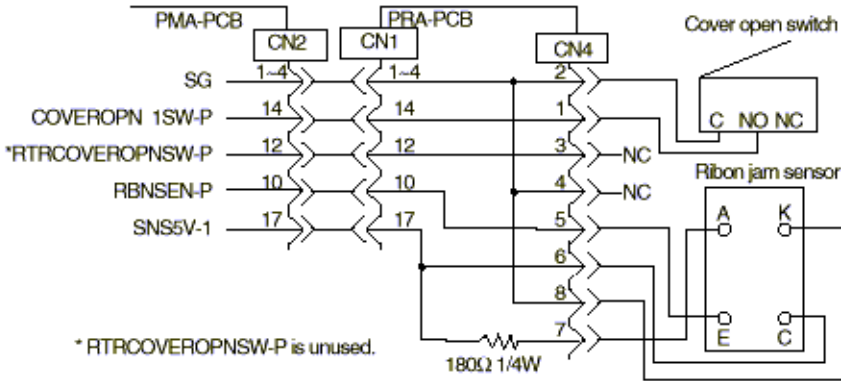

Service Guide for PM4410 Chapter 6 Maintenance

(16) Optical Sensor

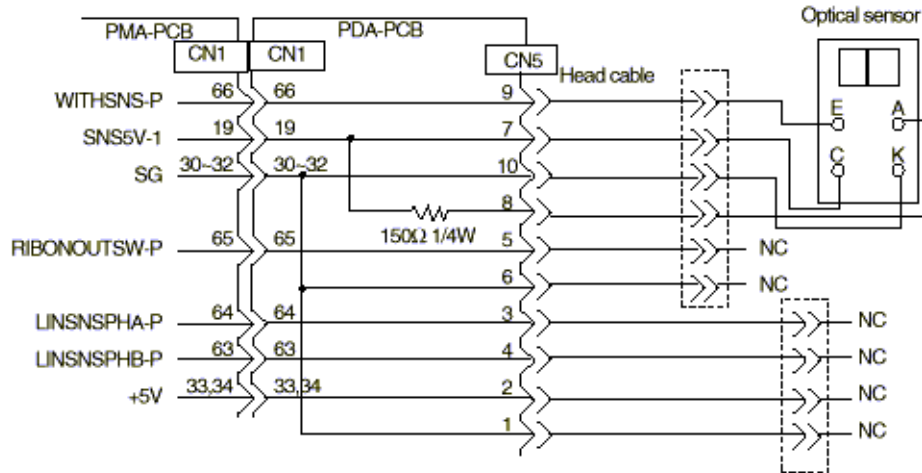

Service Guide for PM4410 Chapter 6 Maintenance

(17) Sheet Top Locating Sensor / Auto Gap Core

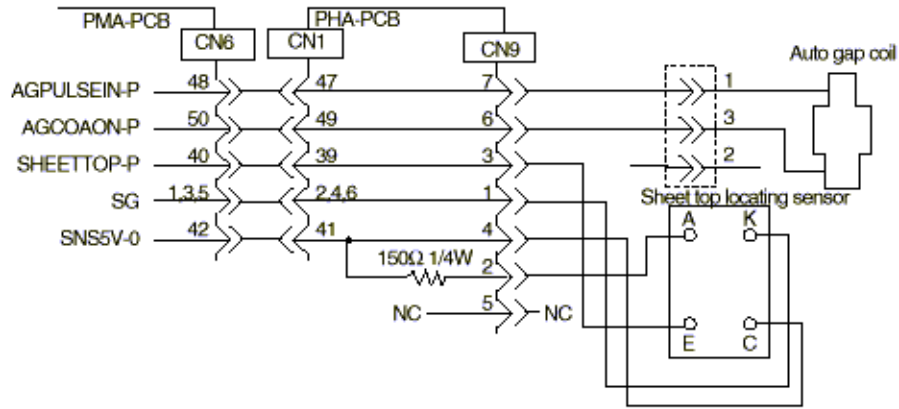

Service Guide for PM4410 Chapter 6 Maintenance

(18) Paper Jam Sensor / Bail Paper End Sensor

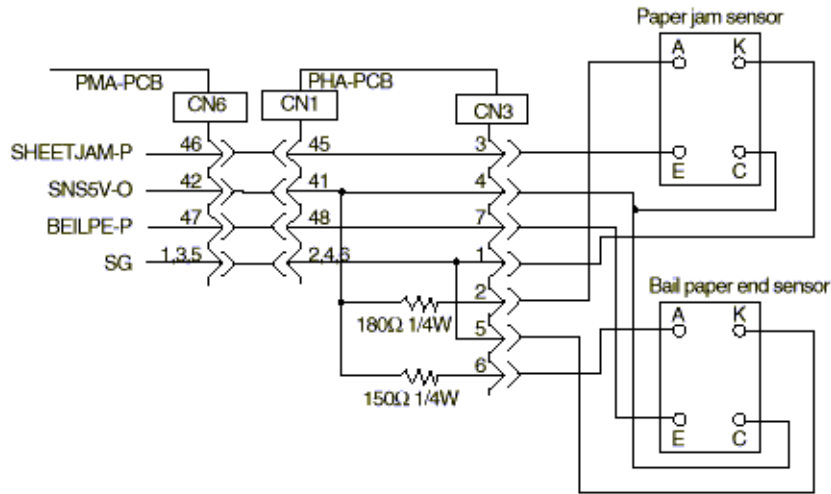

Service Guide for PM4410 Chapter 6 Maintenance

(19) Bail Open Switch / Front Tractor On Switch

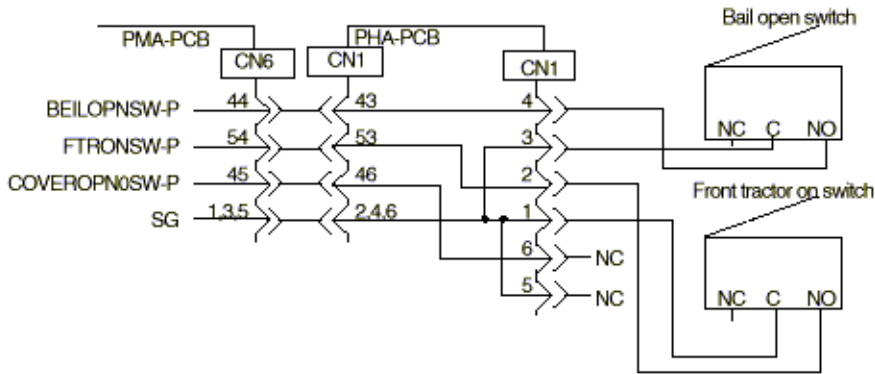

Service Guide for PM4410 Chapter 6 Maintenance

(20) Front Tractor Paper End Switch

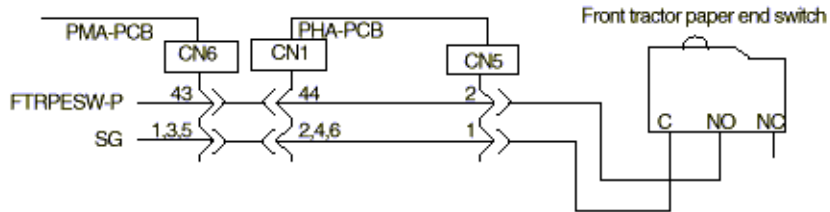

Service Guide for PM4410 Chapter 6 Maintenance

(21) Rear Tractor Paper End Switch

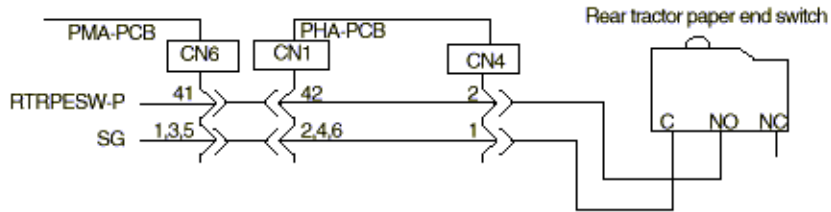

Copyright 1998, Okidata, Division of OKI America, Inc. All rights reserved. See the OKIDATA Business Partner Exchange (BPX) for any updates to this material. (<http://bpx.okidata.com>)

Service Guide for PM4410 Chapter 6 Maintenance

(22) Power Supply Unit

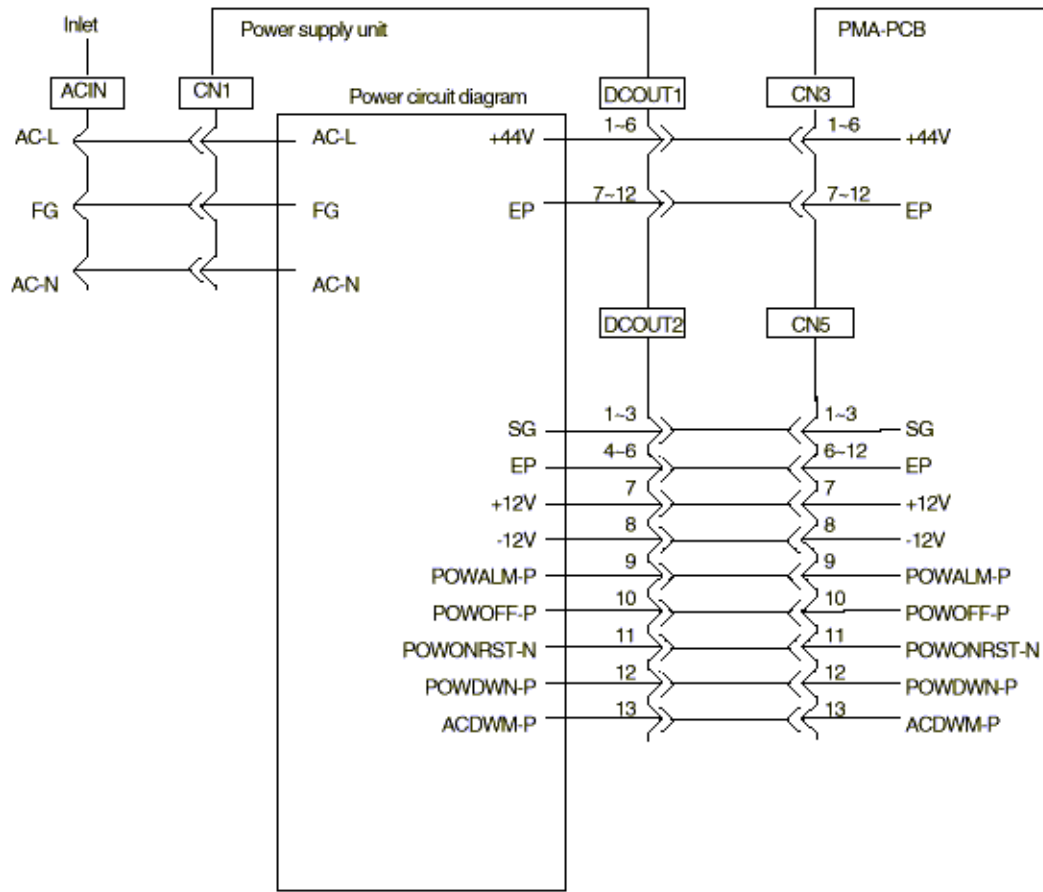

(23) Operation Panel

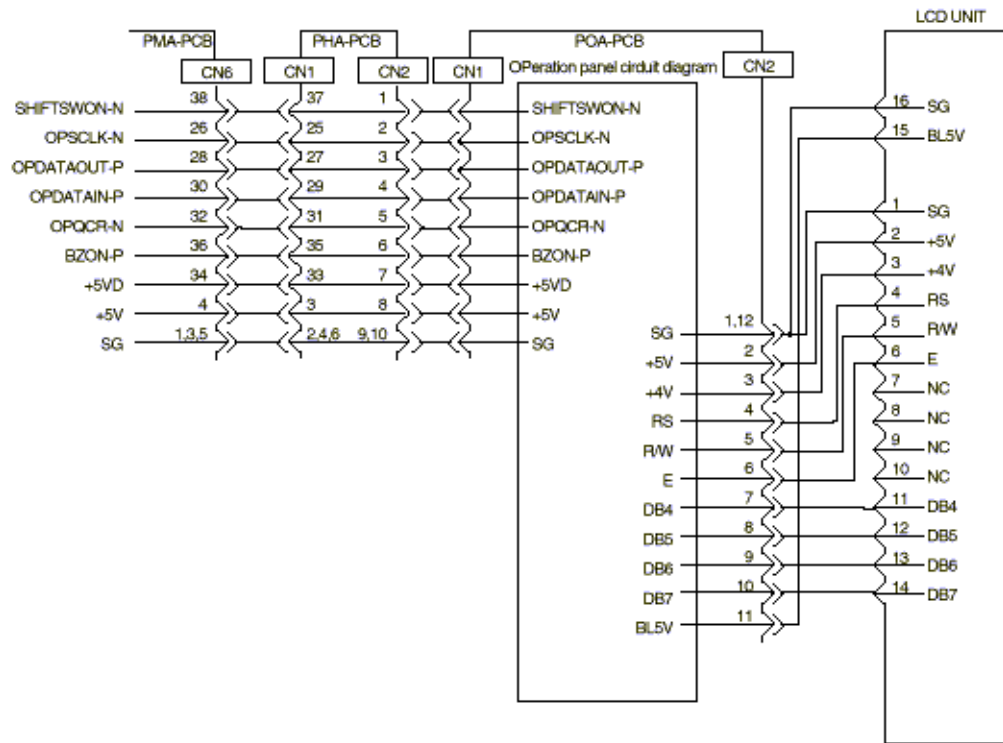



Service Guide for PM4410 Chapter 6 Maintenance

(24) Standard Interface

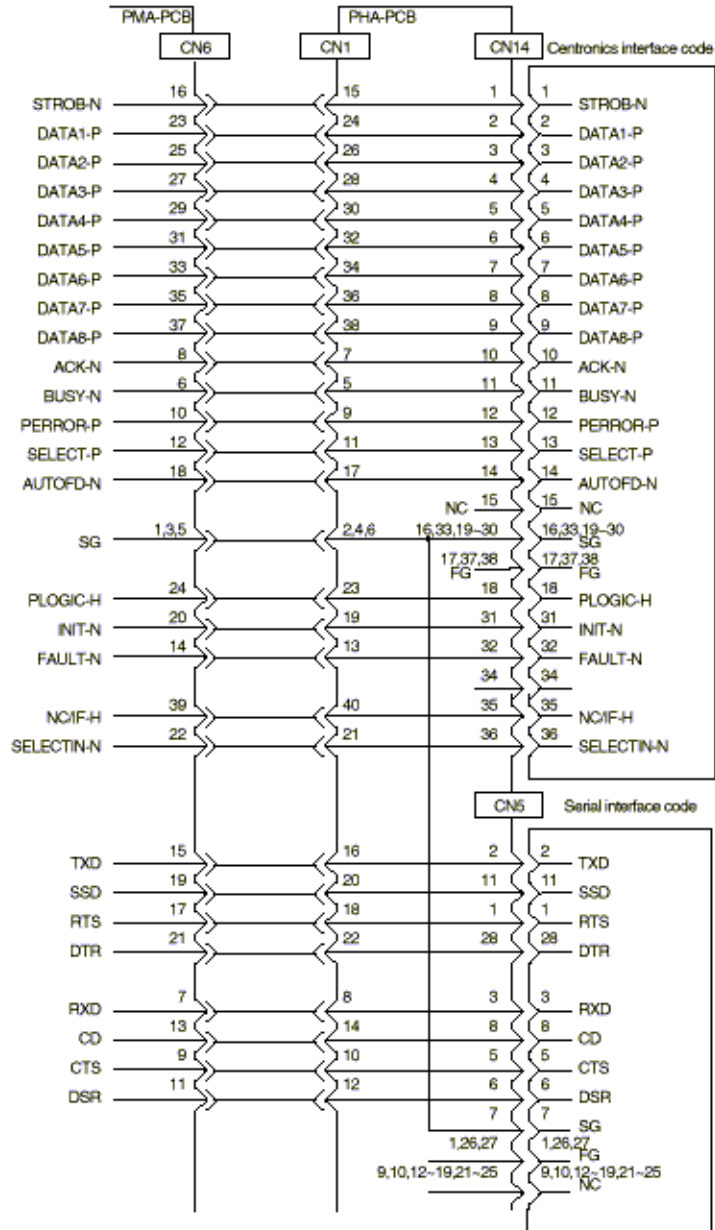

(25) Short Plug

* For setting details see the maintenance manual

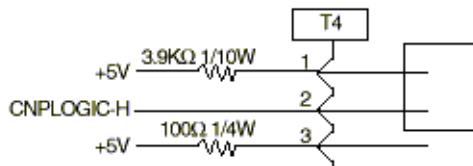
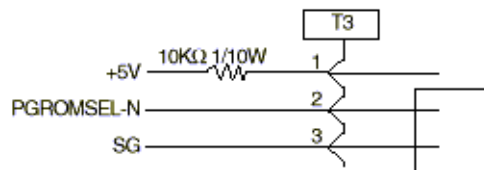
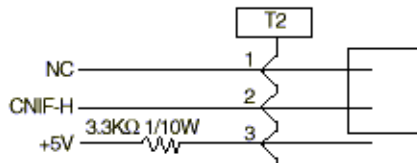
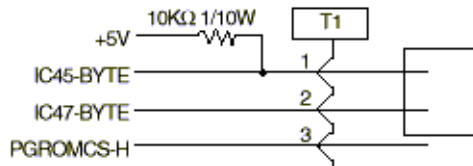

(26) Others

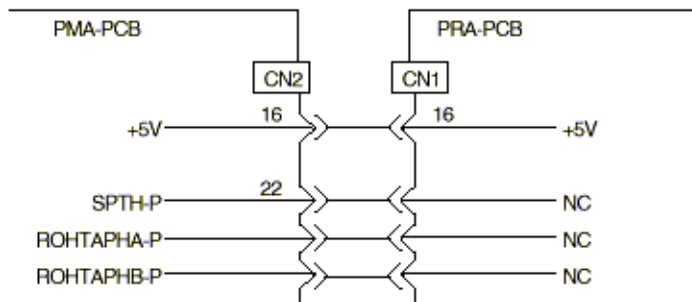
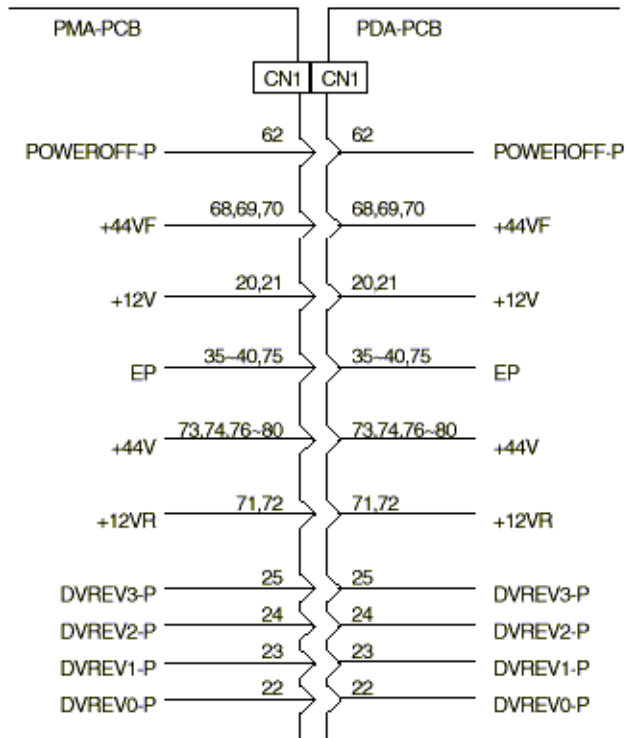

(27) MUPIS Interface (Option)

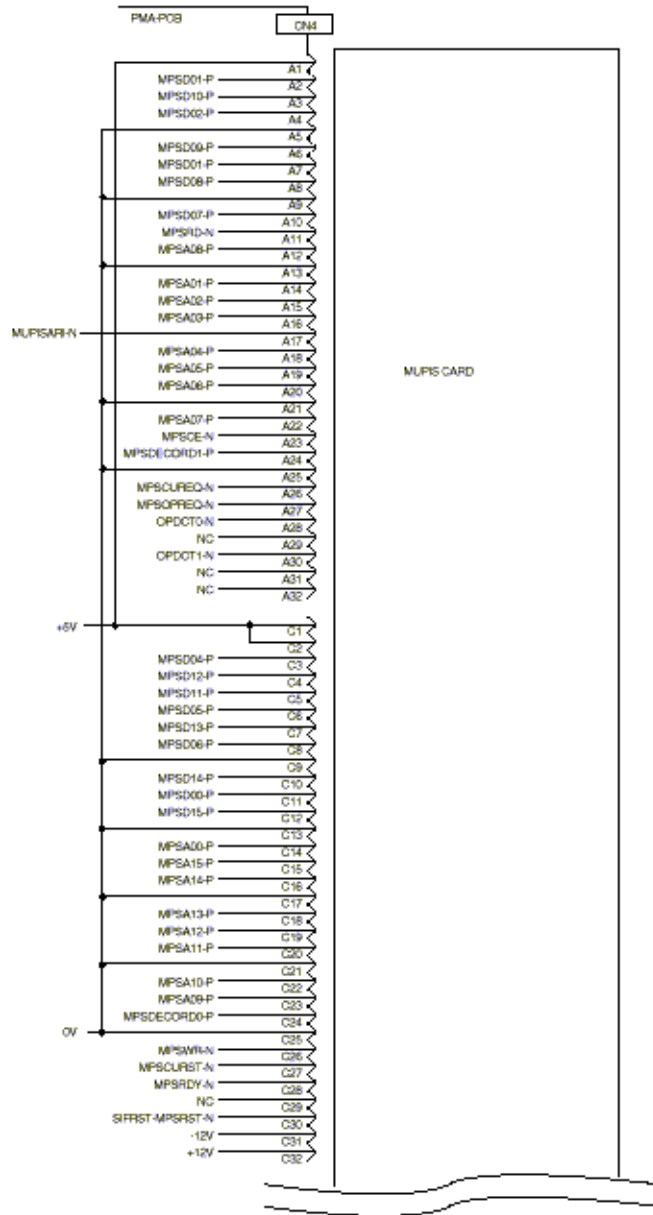

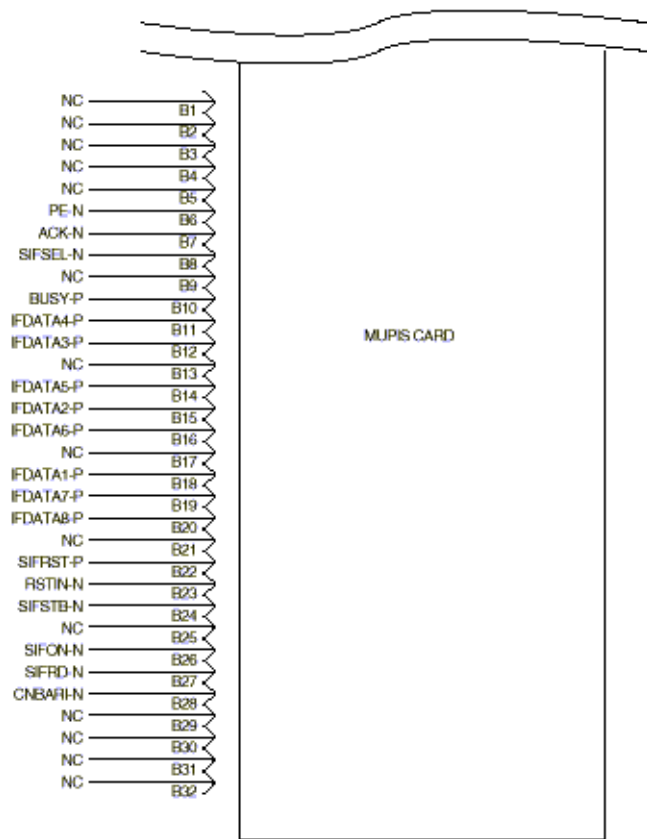

Copyright 1998, Okidata, Division of OKI America, Inc. All rights reserved. See the OKIDATA Business Partner Exchange (BPX) for any updates to this material. (<http://bpx.okidata.com>)



Service Guide for PM4410 Chapter 6 Maintenance

(29) Continuous-Form Paper Cutter (Option)

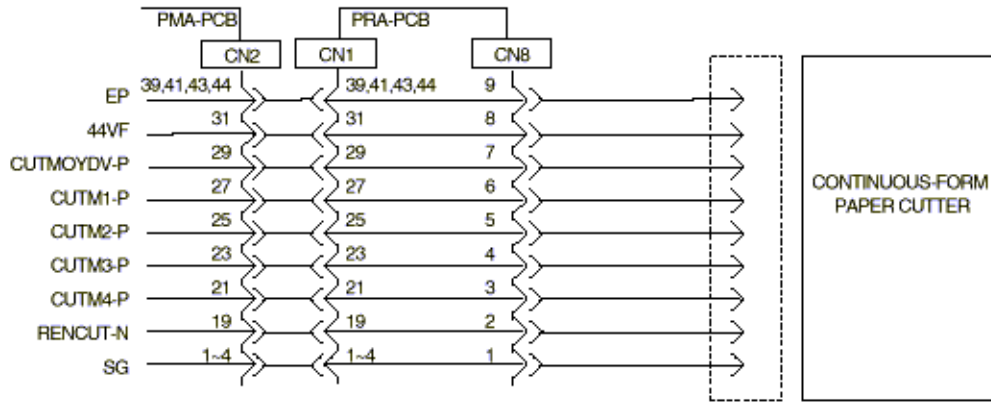

Copyright 1998, Okidata, Division of OKI America, Inc. All rights reserved. See the OKIDATA Business Partner Exchange (BPX) for any updates to this material. (<http://bpx.okidata.com>)



Troubleshooting

- (1) Printer is not powered on at all
- (2) Printer does not operate at all, while Power Lamp is on, Alarm Lamp blinks and nothing is displayed on LCD
- (3) Printer does not operate at all, while Power Lamp is on, Alarm Lamp is on/off and nothing is displayed on LCD
- (4) Spacing is abnormal, while Alarm Lamp is on and "ERROR HOMING" or "ERROR SPACING" is displayed on LCD
- (5) Carriage does not operate at all, while the Alarm Lamp is on and "ERROR AUTOGAP" is displayed on LCD
- (6) After Carriage works, Alarm Lamp goes on and "ERROR (in the upper row), BAIL (in the lower)" is displayed on LCD
- (7) After Carriage operates, Alarm Lamp goes on and "ERROR (in the upper row), PATH CHANGE (in the lower)" is displayed on LCD
- (8) After initialization, Alarm Lamp goes on and "ERROR (in the upper row), RIBBON JAM (in the lower)" is displayed on LCD
- (9) Paper is not line fed, while the Alarm Lamp is on and "ERROR (in the upper row), FEED JAM (in the lower)" is displayed on LCD
- (10) Papers line fed, but "FEED JAM" is displayed on LCD
- (11) Printer does not operate at all, while the Alarm Lamp is on and "ERROR FUSE" is displayed on LCD
- (12) Printer goes off during operation
- (13) Printer does not operate after being turned on, while "INITIALIZING" is displayed on LCD
- (14) Wrong characters are printed or characters are omitted
- (15) Printer operates normally but characters are not printed
- (16) Printer operates normally but characters are not printed.
- (17) Printer operates normally but characters are not printed. (With MUPIS Card used)
- (18) Dots are omitted
- (19) Images are faint
- (20) After Carriage works, the Alarm Lamp goes on and "ERROR AUTOGAP" is displayed on LCD
- (21) Paper is set at Tractor, but printing is not conducted in the state of "PAPER END"
- (22) "COVER OPEN" is displayed on LCD even though Access Card is closed
- (23) Pressing Operation Panel Switches does not make Printer operate (after normal initialization)
- (24) "ERROR, D-RAM" is displayed on LCD, while Alarm Lamp blinks
- (25) "ERROR, PROGRAM-ROM" is displayed on LCD, while Alarm Lamp blinks
- (26) "ERROR, EEPROM" is displayed on LCD, while Alarm Lamp blinks

(27) "ERROR, S-RAM" is displayed on LCD, while Alarm Lamp blinks

(28) "ERROR, CG-ROM" is displayed on LCD while Alarm Lamp blinks

(29) "ERROR, CENTERING" is displayed on LCD, while Alarm Lamp blinks

Copyright 1998, Okidata, Division of OKI America, Inc. All rights reserved. See the OKIDATA Business Partner Exchange (BPX) for any updates to this material. (<http://bpx.okidata.com>)

(1) Printer is not powered on at all

- The AC cable connected properly?

Yes No



- Connect the cable properly.

↓ AC Input Fuse blown?

No Yes



- Replace it with a new AC Input Fuse of the same type and rating.
- Remedied?

No Yes



- End

↓ Replace the power supply unit or connection cable. (See section X.X.X)

↓ Are the +5V outputs in the control board provided?
 Are the (5V outputs in Control Board provided? Slide Control Block toward outside without unplugging the cables. (Stop sliding when the cables becomes straight. Do not extend the cables by force.) Check the voltage between Control Block C75 (side and GND1 or GND2.

Yes No



- The cables to Control Block CN5 and to Power Supply Unit DCOUT2 connected properly?

Yes No



- Connect the cables properly.

↓ The cable to Power Supply Unit CN1 connected properly?

Yes No



- Connect the cable properly.

↓ Replace Power Supply Unit.

↓ The cable to PMA-Board CN6 connected properly?

Yes No



- Connect the cable properly.

↓ The cables to PHA-Board CN1 and CN12 connected properly?

Yes No



- Connect the cables properly.

↓ 1-1



Service Guide for PM4410

Chapter 7 Troubleshooting

(2) Printer does not operate at all, while Power Lamp is on, Alarm Lamp blinks and nothing is displayed on LCD

- The cable to POA-Board CN2 connected properly?

Yes No



- Connect the cable properly.

Replace LCD Unit.



Service Guide for PM4410

Chapter 7 Troubleshooting

(3) Printer does not operate at all, while Power Lamp is on, Alarm Lamp is on/off and nothing is displayed on LCD

- Replace POA-Board. Recovered?

No Yes



- End

▼ Replace Program-ROM. Recovered?

No Yes



- End

▼ Replace PMA-Board

(4) Spacing is abnormal, while Alarm Lamp is on and "ERROR HOMING" or "ERROR SPACING" is displayed on LCD

- Paper rolled into Carriage?

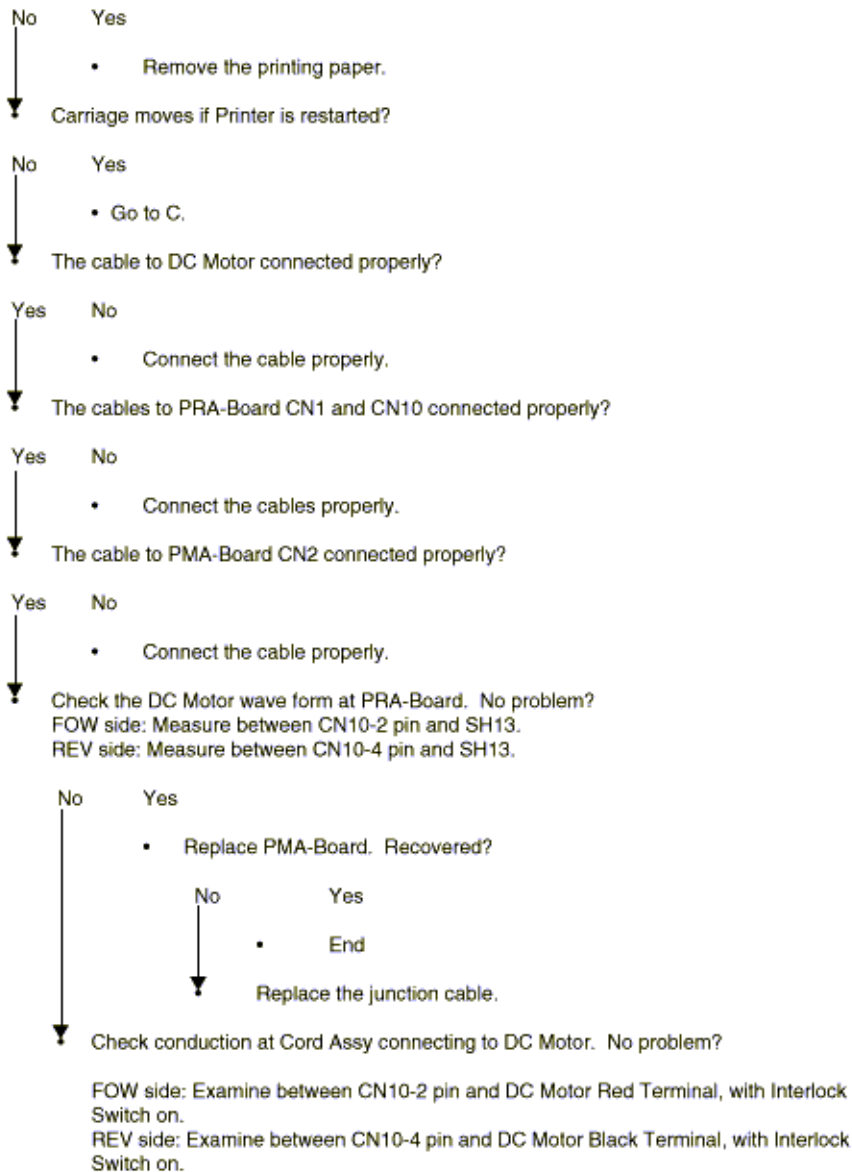

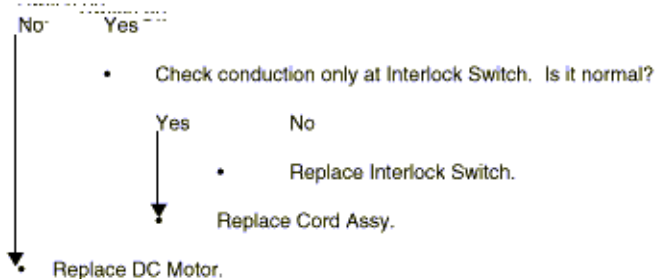

C • Loose Carriage Belt?

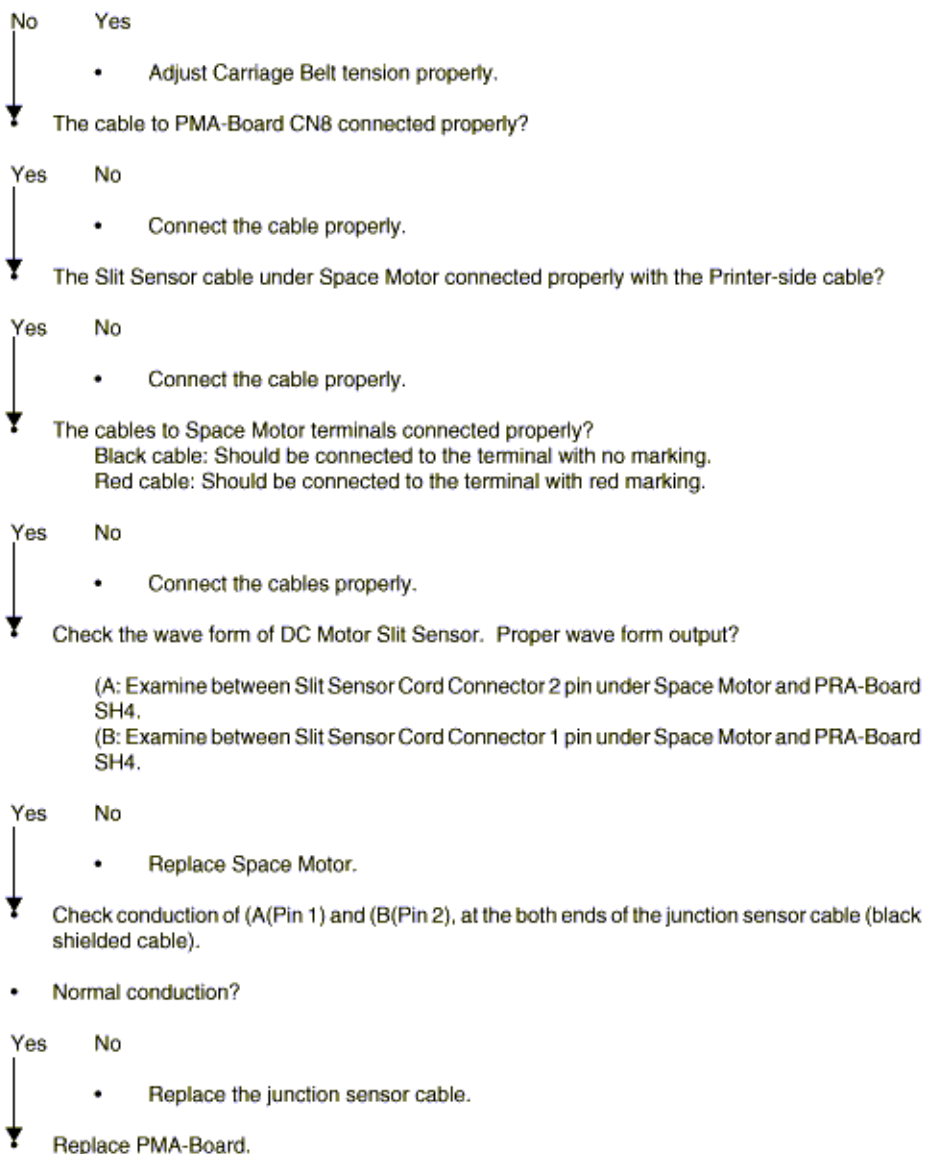

(5) Carriage does not operate at all, while the Alarm Lamp is on and "ERROR AUTOGAP" is displayed on LCD

- Platen works normally during initialization?

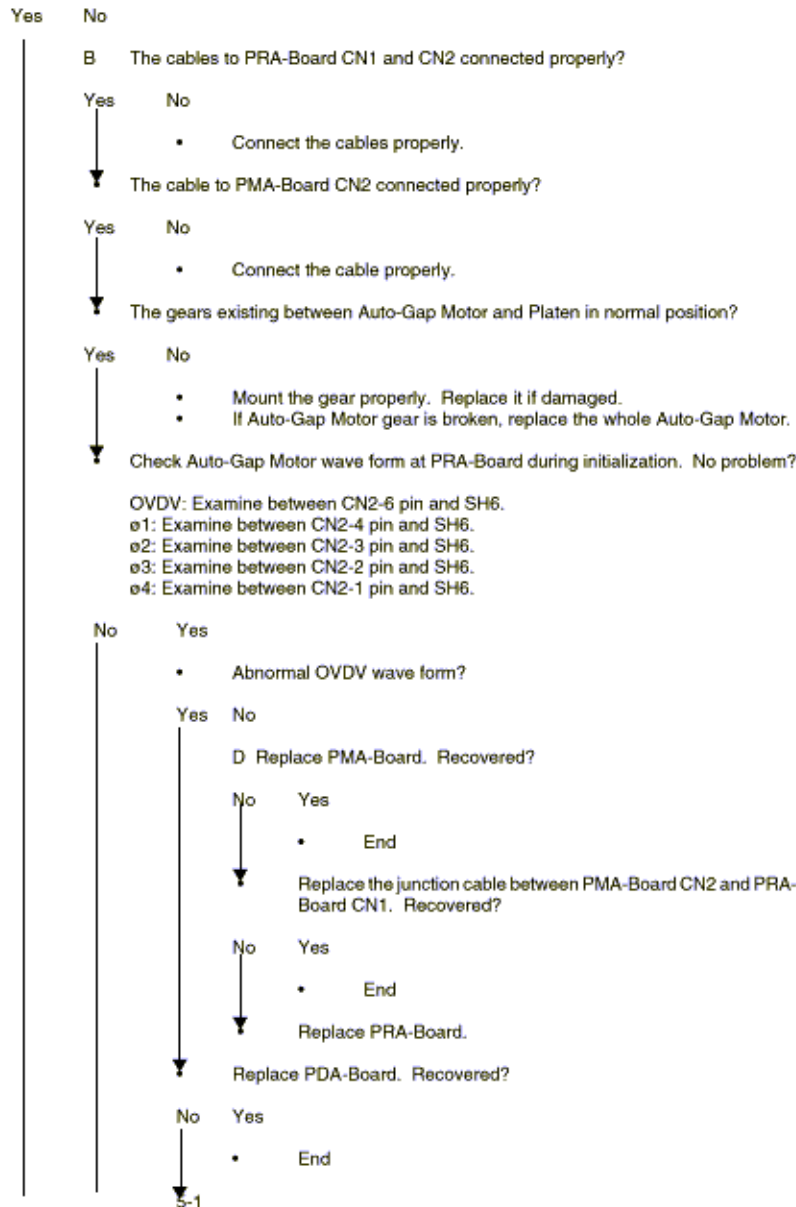

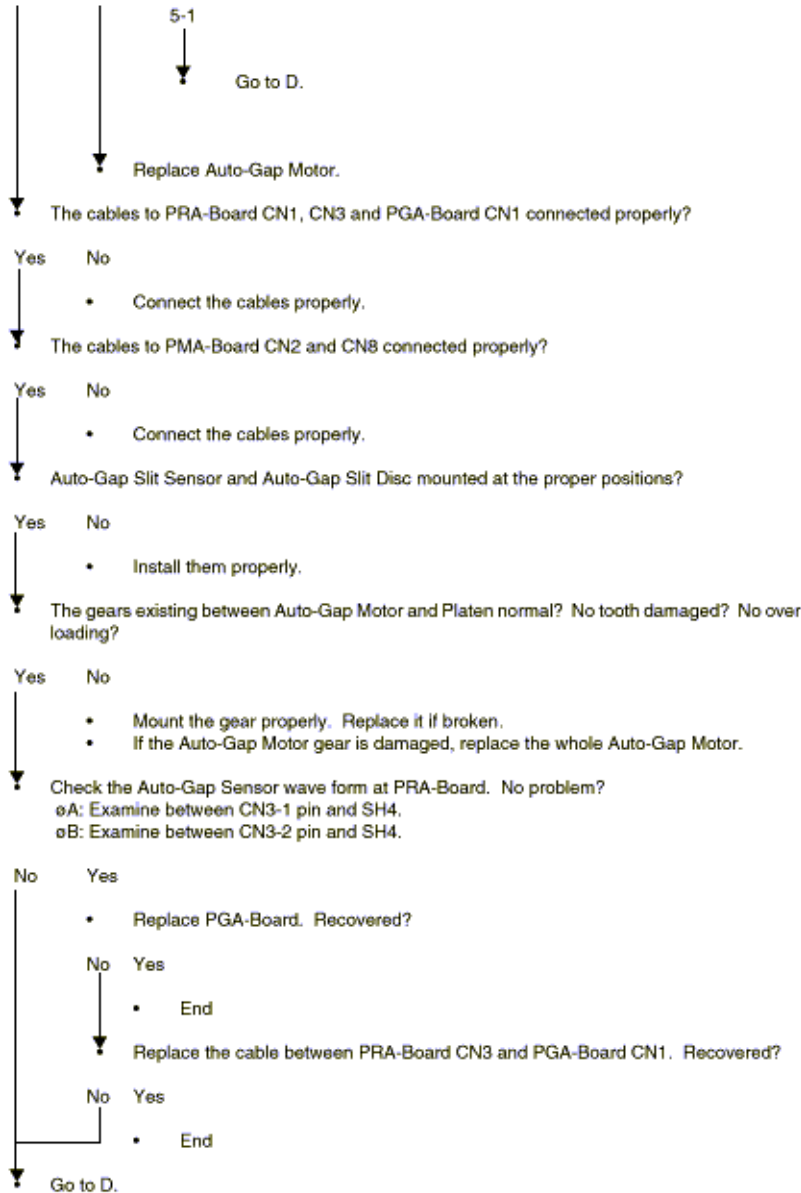



Service Guide for PM4410 Chapter 7 Troubleshooting

(6) After Carriage works, Alarm Lamp goes on and "ERROR (in the upper row, BAIL (in the lower))" is displayed on LCD

- Bail operates during initialization?

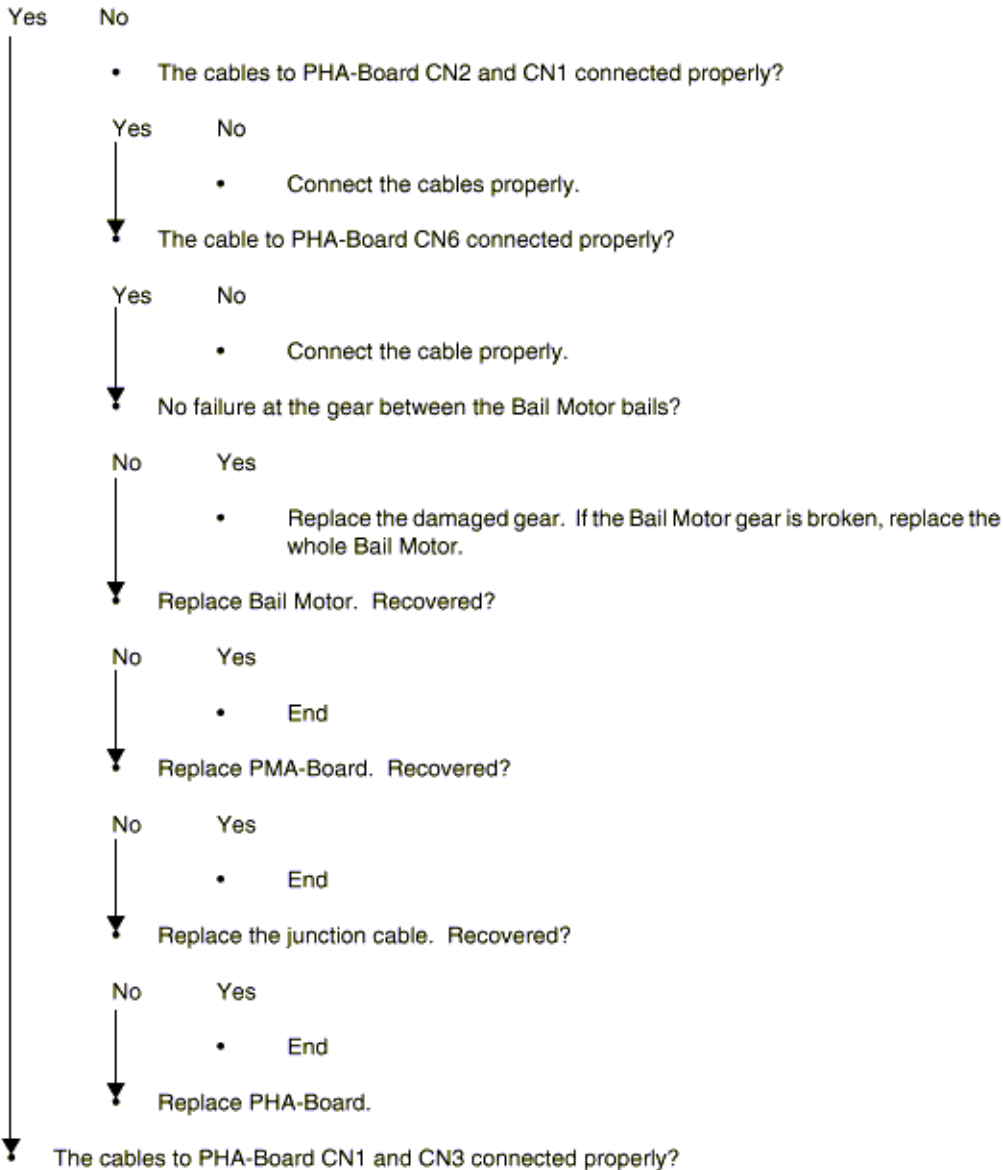

(7) After Carriage operates, Alarm Lamp goes on and "ERROR (in the upper row), PATH CHANGE (in the lower)" is displayed on LCD

- Tractor Change Lever operates during initialization?

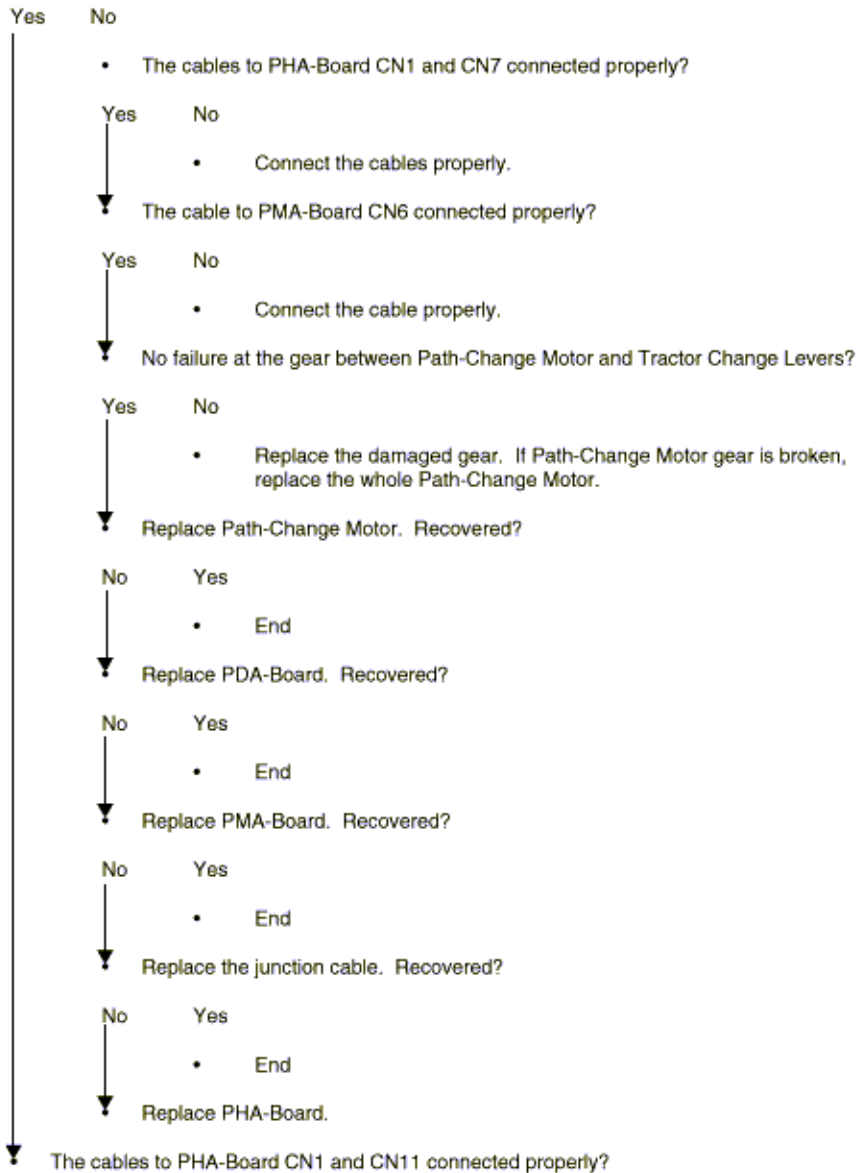

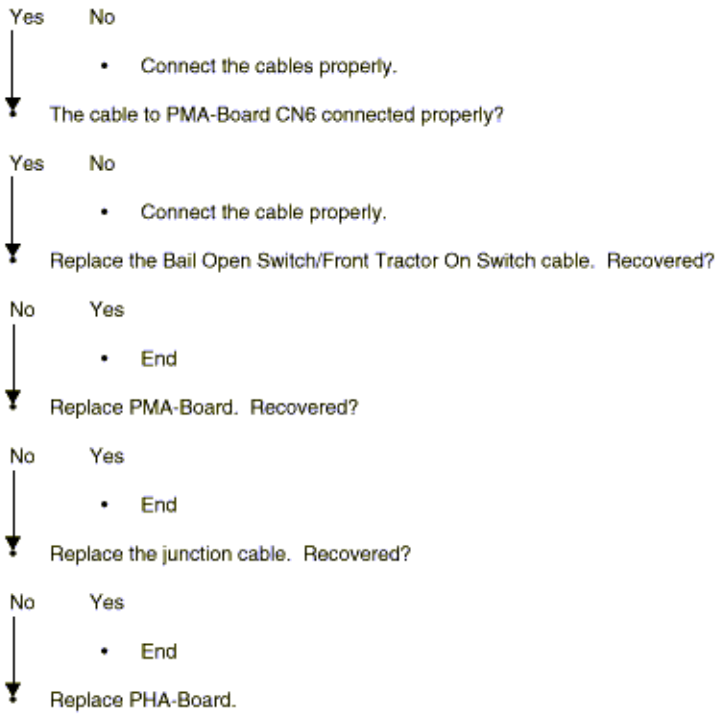

(8) After initialization, Alarm Lamp goes on and "ERROR (in the upper row), RIBBON JAM (in the lower)" is displayed on LCD

- Ribbon fed during initialization?

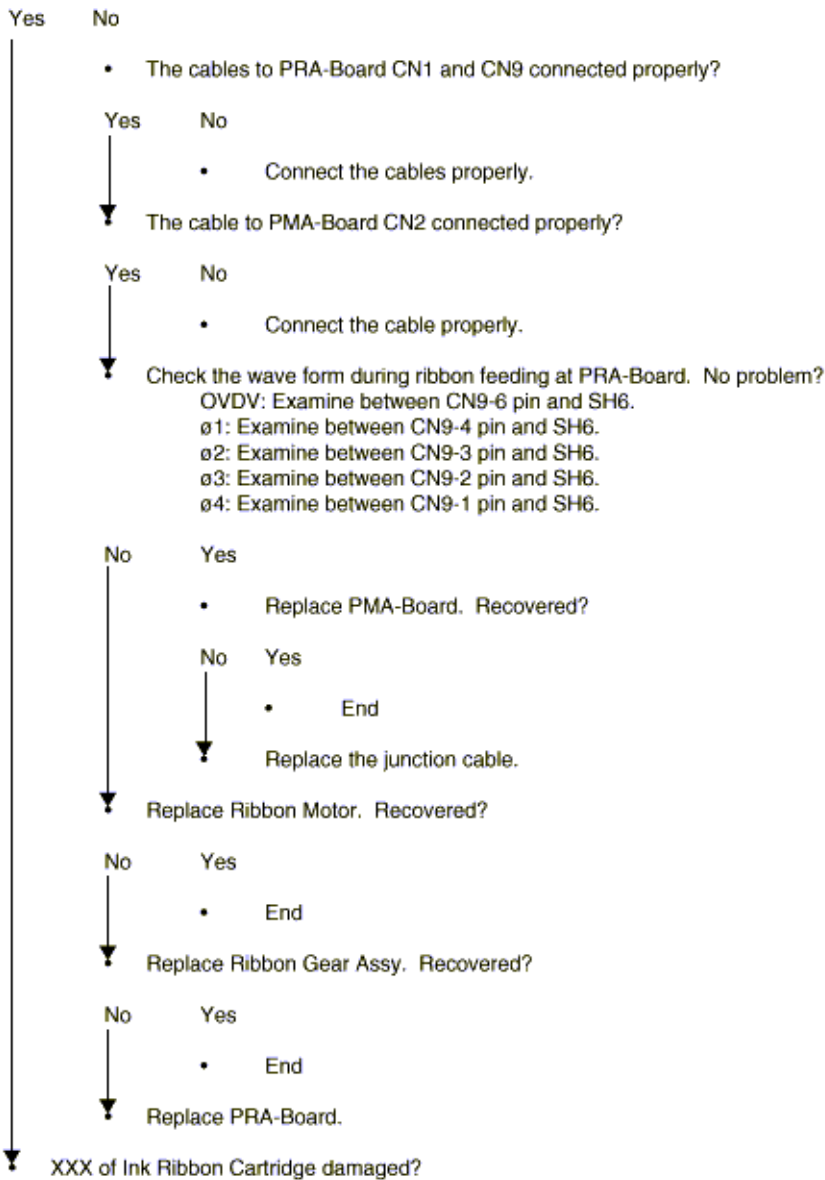

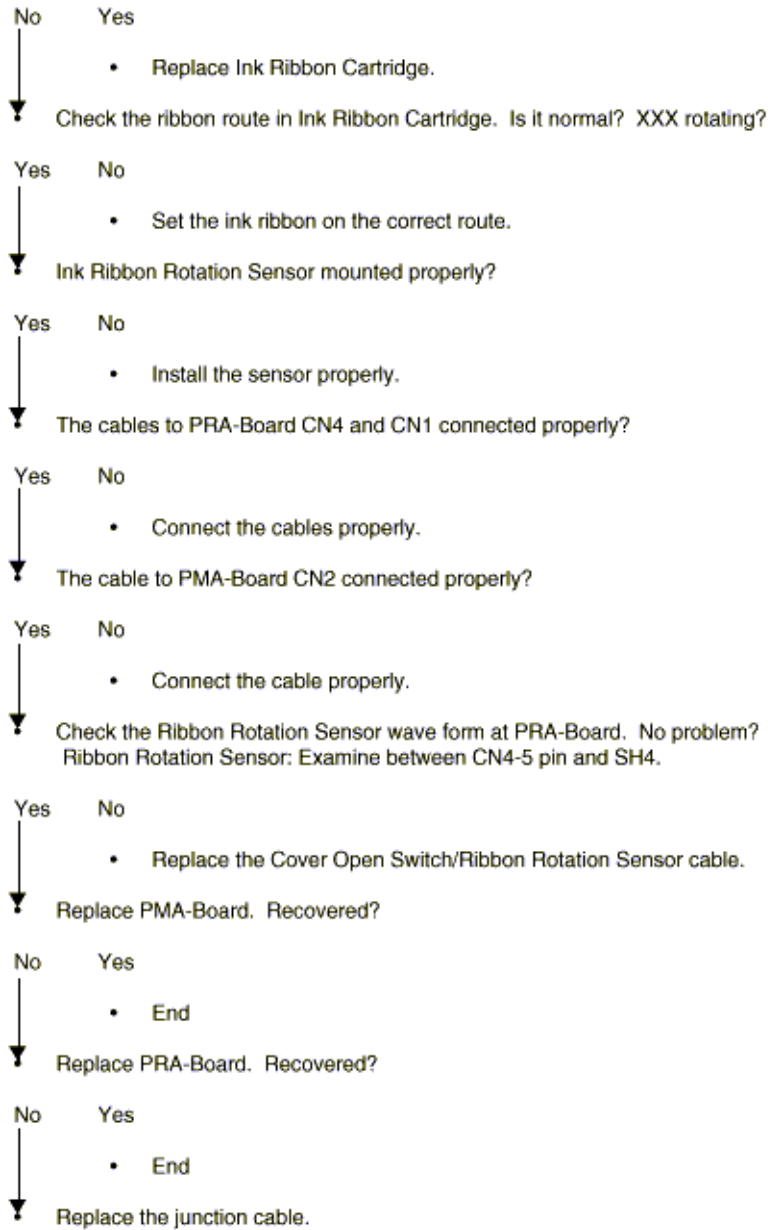



Service Guide for PM4410 Chapter 7 Troubleshooting

(9) Paper is not line fed, while the Alarm Lamp is on and "ERROR (in the upper row), FEED JAM (in the lower)" is displayed on LCD

- The printing paper stuck on the paper feed route?

No Yes



- Remove the paper.

▼ The cables to PHA-Board CN1 and CN13 connected properly?

Yes No



- Connect the cables properly.

▼ The cable to PMA-Board CN6 connected properly?

Yes No



- Connect the cable properly.

▼ No failure at the gear between LF Motor and Tractor Unit?

Yes No



- Replace the broken gear. If the LF Motor gear is damaged, replace the whole LF Motor.

▼ Replace PMA-Board. Recovered?

No Yes



- End

▼ Replace LF Motor. Recovered?

No Yes



- End

▼ Replace the junction cable. Recovered?

No Yes



- End

▼ Replace PHA-Board.



Service Guide for PM4410 Chapter 7 Troubleshooting

(10) Papers line fed, but "FEED JAM" is displayed on LCD

- The cables to PHA-Board CN1 and CN3 connected properly?

Yes No



- Connect the cables properly.

↓ The cable to PMA-Board CN6 Connector connected properly?

Yes No



- Connect the cable properly.

↓ Feed Jam Sensor mounted properly?

Yes No



- Install it properly.

↓ Replace the FEED JAM/Bail Paper End Sensor cable. Recovered?

No Yes



- End

↓ Replace PMA-Board. Recovered?

No Yes



- End

↓ Replace the junction cable. Recovered?

No Yes



- End

↓ Replace PHA-Board.



Service Guide for PM4410 Chapter 7 Troubleshooting

(11) Printer does not operate at all, while the Alarm Lamp is on and "ERROR FUSE" is displayed on LCD

- The cable to PMA-Board CN3 connected properly?

Yes No



- Connect the cable properly.

↓ The cable to Printer Unit Connector DCOUT2 connected properly?

Yes No



- Connect the cable properly.

↓ PMA-Board F1 and F2 mounted?

Yes No



- Install them.

↓ PMA-Board F1 and F2 blown?

No Yes



- Replace the blown-out fuse. Recovered?

No Yes



- End

↓ Turn Printer on, with PMA-Board CN2 and CN6 unplugged. Are the fuses blown?

No Yes



- Which fuse is blown, F1 or F2?

F1 F2



- Short circuit occurs at PDA-Board, between HTA1-5 pin and 4 pin and between HTA1-1 pin and 2 pin?

No Yes



- Replace PDA-Board.

↓ Replace PMA-Board.

↓ Replace PMA-Board.

↓ Turn Printer on, with PMA-Board CN2 unplugged. Are the fuses blown?

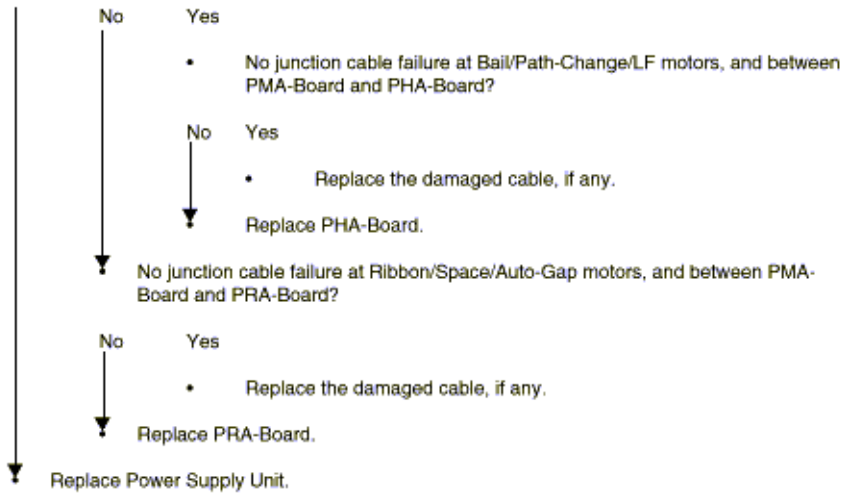

Copyright 1998, Okidata, Division of OKI America, Inc. All rights reserved. See the OKIDATA Business Partner Exchange (BPX) for any updates to this material. (<http://bpx.okidata.com>)



(12) Printer goes off during operation

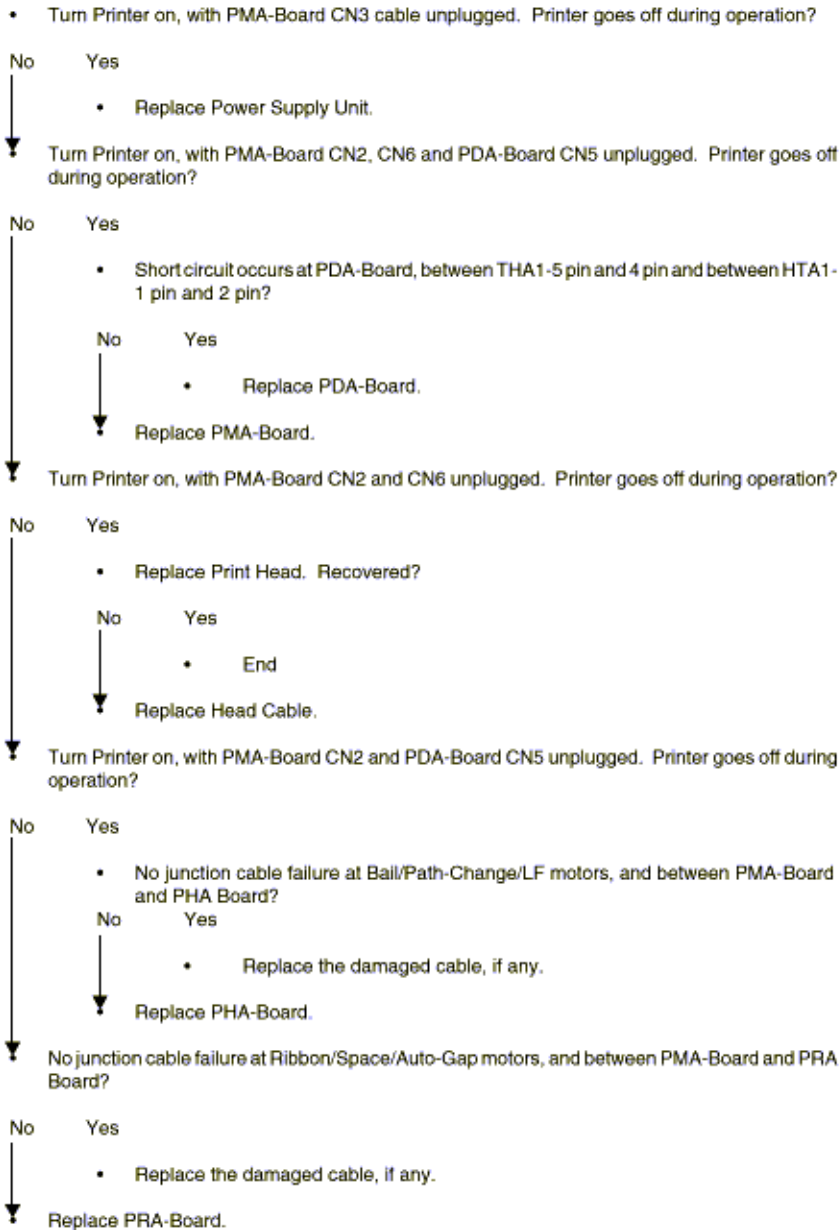



Service Guide for PM4410 Chapter 7 Troubleshooting

(13) Printer does not operate after being turned on, while "INITIALIZING" is displayed on LCD

- The interface cable connected properly?

Yes No



- Connect the cable properly.



Replace the interface cable. Recovered?

No Yes



- End



Replace PMA-Board.



(14) Wrong characters are printed or characters are omitted

- Self Diagnosis Printing conducted normally?

Yes No



• Replace PMA-Board.



The interface cable and the network cable connected properly?

Yes No



- Connect the cables properly.



The cables to PMA-Board CN6 and PHA-Board CN1 connected properly?

Yes No



- Connect the cables properly.



Replace the interface cable. Recovered?

No Yes



- End



Replace the junction cables to PMA-Board and to PHA-Board. Recovered?

No Yes



- End



Replace PHA-Board.

(15) Printer operates normally but characters are not printed

• Self Diagnosis Printing conducted normally?

Yes No

- Replace PMA-Board.

↓ The interface cable connected properly?

Yes No

- Connect the cable properly.

↓ Replace the interface cable. Recovered?

No Yes

- End

↓ The interface is parallel or serial?

Parallel Serial

- The serial interface setting adjusted for the system?

Yes No

- Set it properly.

↓ Check -12V output at PMA-Board.
Slide Control Block toward outside without unplugging the cables. (Stop sliding when the cables becomes straight. Do not extend the cables by force.)
Check the voltage between CN5-1 pin and CN5-8 pin. Is -12V output?

Yes No

- Check conduction at the 8 pin on the junction cable between PMA-Board CN5 and Power Supply Unit Connector DCOUT2.
- Normal conduction?

Yes No

- Replace the cable.

↓ Replace Power Supply Unit.

↓ The cable between PMA-Board CN6 and PHA-Board CN1 connected properly?

Yes No

- Connect the cable properly.

↓ Replace the junction cable between PMA-Board CN6 and PHA-Board CN1. Recovered?

No Yes
↓
• End
Replace PHA-Board. Recovered?

No Yes
↓
• End
Replace PMA-Board.

Copyright 1998, Okidata, Division of OKI America, Inc. All rights reserved. See the OKIDATA Business Partner Exchange (BPX) for any updates to this material. (<http://bpx.okidata.com>)

(16) Printer operates normally but characters are not printed.

- Self Diagnosis Printing conducted normally?

Yes No



- Replace PMA-Board.

▼ The interface cable connected properly?

Yes No



- Connect the cable properly.

▼ The serial interface setting adjusted for the system?

Yes No



- Set it properly.

▼ Replace the interface cable. Recovered?

No Yes



- End

▼ With Menu, check Printer's recognition of PAA-Board, the Option Serial Board attachment. At Menu Setting, select "Set-up" as Group and "Host Interface" as Item. If "Opt. Card" is displayed in Set Window, Printer recognizes PAA-Board.

- PAA-Board recognized by Printer?

Yes No



- PAA-Board and PMA-Board connected properly.

Yes No



- Connect them properly.

▼ Replace PAA-Board.

▼ With Menu, check Printer's recognition of Option Serial Board. At Menu Setting, if "Serial I/F (OP)" is displayed as Group, Printer recognizes Option Serial Board.

- Option Serial Board recognized by Printer?

Yes

No

- Option Serial Board connected to PAA-Board properly?

Yes

No

- Connect it properly.

Replace Option Serial Board.

Check -12V output at PMA-Board.

Slide Control Block toward outside without unplugging the cables. (Stop sliding when the cables becomes straight. Do not extend the cables by force.)

- Check the voltage between CN5-1 pin and CN5-8 pin. Is -12V output?

Yes

No

- Check conduction at the 8 pin on the junction cable between PMA-Board CN5 and Power Supply Unit Connector DCOU2.

Yes

No

- Replace the cable.

Replace Power Supply Unit.

Replace PMA-Board.



Service Guide for PM4410 Chapter 7 Troubleshooting

(17) Printer operates normally but characters are not printed. (With MUPIS Card used)

- Self Diagnosis Printing conducted normally?

Yes No

- Replace PMA-Board.

- ▼ The network cable to MUPIS Card (LAN Cable) connected properly?

Yes No

- Connect the cable properly.

- ▼ Replace the network cable to MUPIS Card (LAN Cable). Recovered?

No Yes

- End

- ▼ With Menu, check Printer's recognition of MUPIS Card.
At Menu Setting, select "Set-up" as Group and "Host Interface" as Item. If "OKI HSP" is displayed in Set Window, Printer recognizes the card.

- MUPIS Card recognized by Printer?

Yes No

- MUPIS Card connected to PMA-Board properly?

Yes No

- Connect it properly.

- ▼ Replace MUPIS-Board.

- ▼ Check -12V output at PMA-Board.
Slide Control Block toward outside without unplugging the cables. (Stop sliding when the cables becomes straight. Do not extend the cables by force.)

- Check the voltage between CN5-1 pin and CN5-8 pin. Is -12V output?

Yes No

- Check conduction at the 8 pin on the junction cable between PMA-Board CN5 and Power Supply Unit Connector DCOU2.

Yes No

- Replace the cable.

- ▼ Replace Power Supply Unit.

- ▼
- Replace PMA-Board.
-



(18) Dots are omitted

- Head Gap adjusted properly?

Yes No

- Adjust Head Gap according to Maintenance Manual.

▼ Implement Head Pin Test according to Maintenance Manual.

- Is any pin missing?

Yes No

- Go to 14.

▼ Replace Print Head. Recovered?

No Yes

- End

▼ Replace PDA-Board. Recovered?

No Yes

- End

▼ Replace PMA-Board. Recovered?

No Yes

- End

▼ Replace Head Cable.



(19) Images are faint

- End of Ink Ribbon life?

No Yes



- Replace Ink Ribbon.

▼ Head Gap adjusted properly?

Yes No



- Adjust it properly.

▼ Check +44V output at PMA-Board.

Slide Control Block toward outside without unplugging the cables. (Stop sliding when the cables becomes straight. Do not extend the cables by force.)

- In this state, turn Printer on and check the voltage between CN3 -1 pin and CN3 Pin 12.
- More than +38V output?

Yes No



- Replace Power Supply Unit.

▼ Replace Print Head. Recovered?

No Yes



- End



- Replace PDA-Board.
-

(20) After Carriage works, the Alarm Lamp goes on and "ERROR AUTOGAP" is displayed on LCD

- Platen operates normally during initialization?

Yes No

- Go to B.

▼ Adjust Head Gap. Recovered?

No Yes

- End

▼ Adjust Core Gap. Recovered?

No Yes

- End

▼ The cables to PRA-Board CN1, CN3 and PGA-Board CN1 connected properly?

Yes No

- Connect the cables properly.

▼ The cables to PMA-Board CN2, CN6 and CN8 connected properly?

Yes No

- Connect the cables properly.

▼ The cables to PHA-Board CN1 and CN9 connected properly?

Yes No

- Connect the cables properly.

▼ Auto-Gap Slit Sensor and Auto-Gap Slit Disc mounted at the proper positions?

Yes No

- Install them properly.

▼ The gear existing between Auto-Gap Motor and Platen normal? No tooth broken? No overloading?

Yes No

- Install the gear properly. Replace it if damaged.
- If the Auto-Gap Motor gear is broken, replace the whole Auto-Gap Motor.

▼ Check Auto-Gap Slit Sensor wave form at PRA-Board. No problem?
ø1: Examine between CN3-1 pin and SH4.

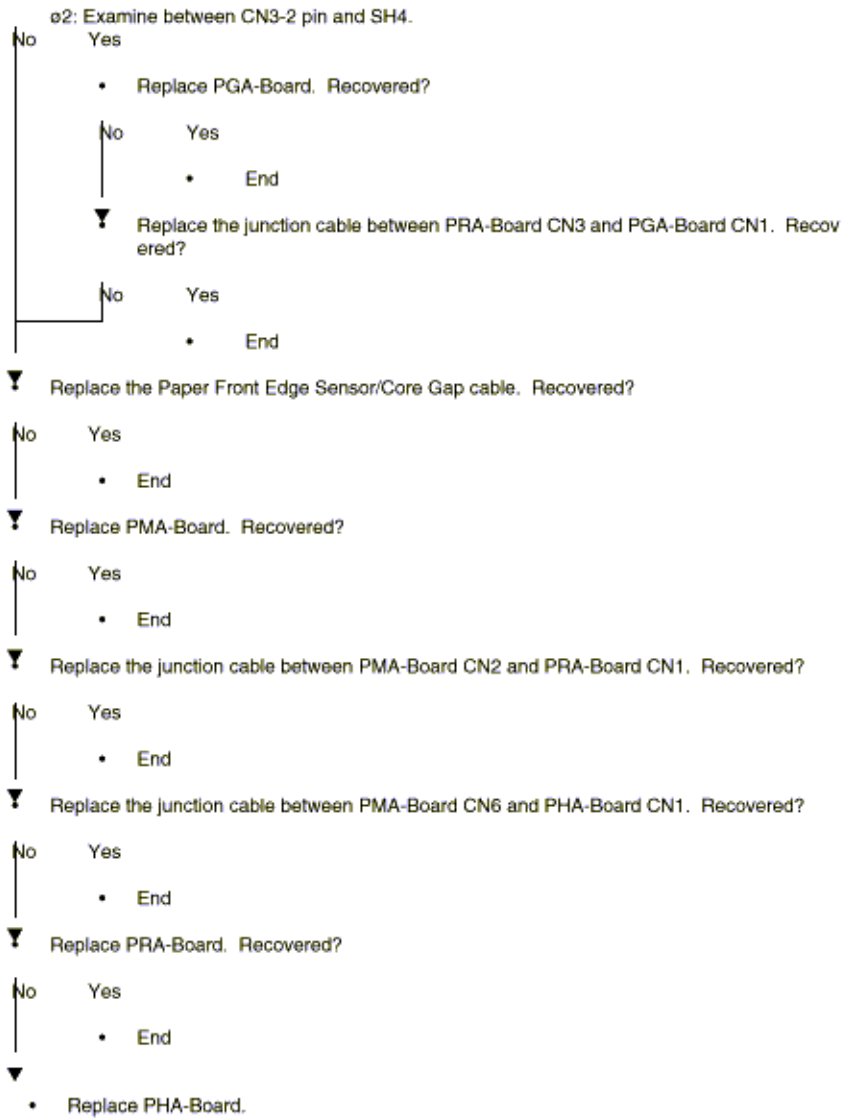



Service Guide for PM4410 Chapter 7 Troubleshooting

(21) Paper is set at Tractor, but printing is not conducted in the state of "PAPER END"

- Intervals between lines occur during printing.
- Check ON/OFF operation of the Tractor used (Front or Rear), according to Maintenance Manual.
- Normal N/OFF operation?

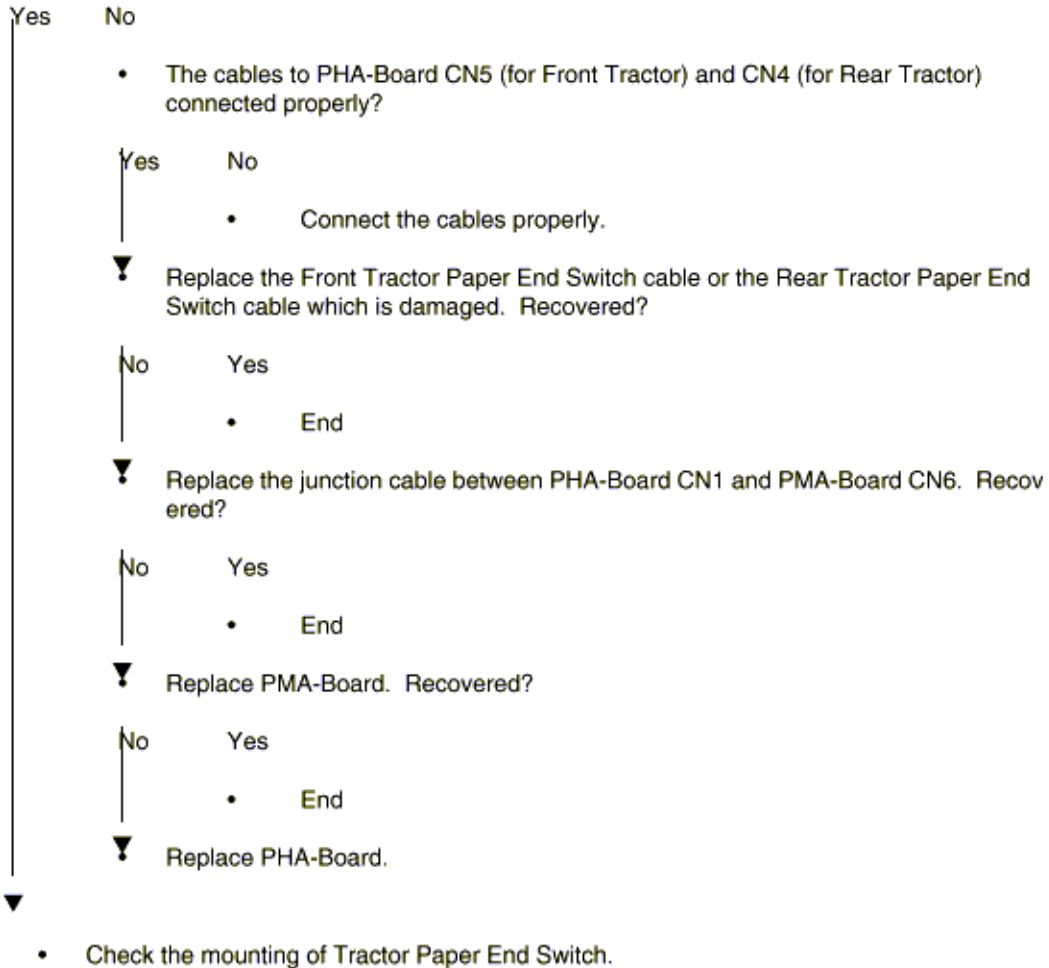



Service Guide for PM4410 Chapter 7 Troubleshooting

(22) "COVER OPEN" is displayed on LCD even though Access Card is closed

- Check ON/OFF operation of Cover Open Switch, according to Maintenance Manual.
- Normal ON/OFF operation?

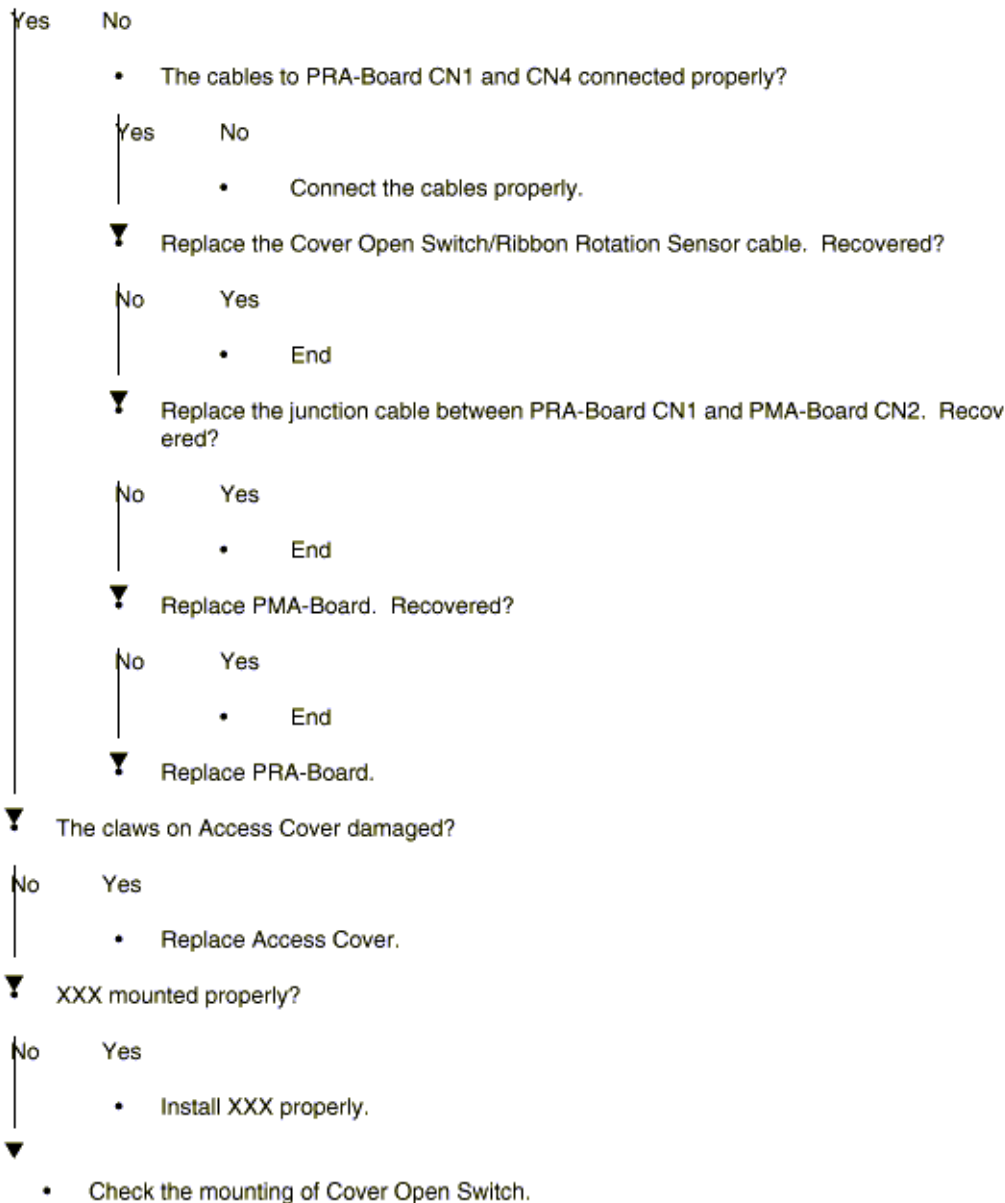



Service Guide for PM4410

Chapter 7 Troubleshooting

(23) Pressing Operation Panel Switches does not make Printer operate (after normal initialization)

- The cable between POA-Board CN1 and PHA-Board CN12 connected properly?

Yes No

- Connect the cable properly.



Check conduction at the junction cable between POA-Board CN1 and PHA-Board CN12.

- Normal conduction?

Yes No

- Replace the junction cable.



Replace POA-Board. Recovered?

No Yes

- End



Replace the junction cable between PMA-Board CN6 and PHA-Board CN1. Recovered?

No Yes

- End



Replace PHA-Board. Recovered?

No Yes

- End



- Replace PMA-Board.
-



Service Guide for PM4410 Chapter 7 Troubleshooting

(24) "ERROR, D-RAM" is displayed on LCD, while Alarm Lamp blinks

- Replace PMA-Board.
-

Copyright 1998, Okidata, Division of OKI America, Inc. All rights reserved. See the OKIDATA Business Partner Exchange (BPX) for any updates to this material. (<http://bpx.okidata.com>)



Service Guide for PM4410

Chapter 7 Troubleshooting

(25) "ERROR, PROGRAM-ROM" is displayed on LCD, while Alarm Lamp blinks

- Program-ROM mounted properly on PMA-Board?

Yes No



- Install it properly.



Replace Program-ROM. Recovered?

No Yes



- End



Replace PMA-Board.



Service Guide for PM4410 Chapter 7 Troubleshooting

(26) "ERROR, EEPROM" is displayed on LCD, while Alarm Lamp blinks

- EEPROM mounted properly on PMA-Board?

Yes No



- Install it properly.



Replace EEPROM. Recovered?

No Yes



- End



Replace PMA-Board.



Service Guide for PM4410 Chapter 7 Troubleshooting

Page: 128

(27) "ERROR, S-RAM" is displayed on LCD, while Alarm Lamp blinks

- Replace PMA-Board.

Copyright 1998, Okidata, Division of OKI America, Inc. All rights reserved. See the OKIDATA Business Partner Exchange (BPX) for any updates to this material. (<http://bpx.okidata.com>)



Service Guide for PM4410 Chapter 7 Troubleshooting

(28) "ERROR, CG-ROM" is displayed on LCD while Alarm Lamp blinks

- CG-ROM mounted properly on PMA-Board?

Yes No

- Install it properly.

▼ Replace CG-ROM. Recovered?

No Yes

- End

▼ Replace PMA-Board.



Service Guide for PM4410 Chapter 7 Troubleshooting

(29) "ERROR, CENTERING" is displayed on LCD, while Alarm Lamp blinks

- Go to 4.

Copyright 1998, Okidata, Division of OKI America, Inc. All rights reserved. See the OKIDATA Business Partner Exchange (BPX) for any updates to this material. (<http://bpx.okidata.com>)

Total Assembling Diagram

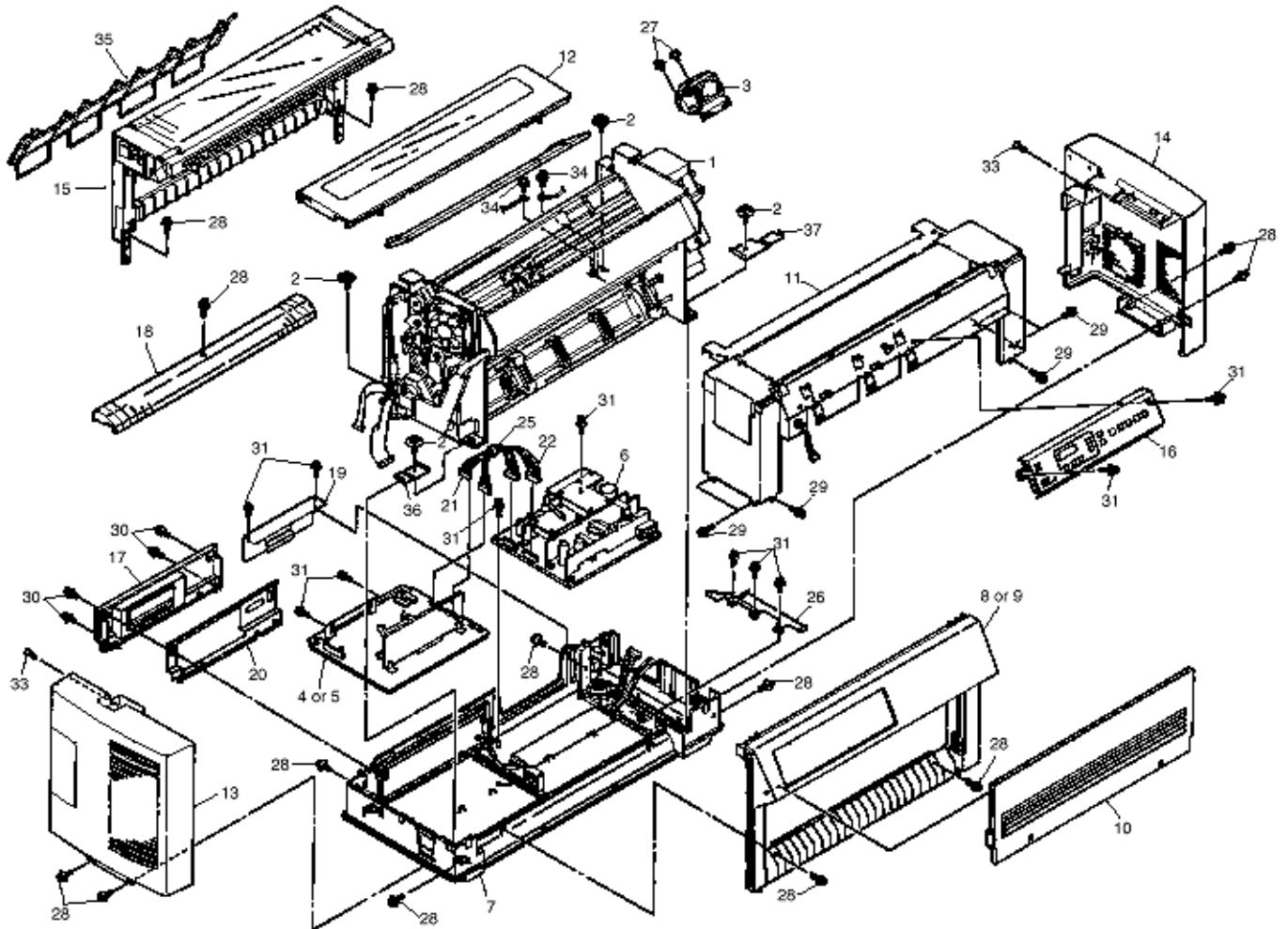

No.	Parts No.	Name	Qty	Remarks
1	40496601	Printer Unit	1	
2	50319002	Cup Screw with Washer		
3	40538101	Serial Dot Matrix Print Head - PM4410		
4	40750403	PMA/PDA PCB	1	
5				
6	40414001	Power Unit	1	
7	40677101	Cover Assy - Lower	1	
8	40677201	Cover Assy - Front	1	
9	40677202			
10	40677401	Door Assy - Front	1	
12	40520201	Cover Assy - Access	1	
13	40677601	Cover Assy - Side (L)	1	
14	40677901	Cover Assy - Side (R)	1	

15	40678301	Frame Assy - Rear	1	
16	40755801	Frame Assy - OpePane	1	
17	40520501	Cover Rear (B)	1	
18	40627701	Guide - Paper (B)	1	
19	40738901	Cover Blank - (Lower)	1	
20	40777901	Plate - Earth (Cover Rear)	1	
21	40533301	Connection Cord - Wire	1	
22	56616806	Nylon Connector Cord	1	
23		Label	1	
24		Label Fuse	1	
25	55505203	TFC-20-10-10 Beads Core	1	
26		Cover Cable	1	
27-34		Screw		
35	40658201	Guide - Sheet	1	
36		Mechanical Clamp (L)	1	
37		Mechanical Clamp (R)	1	

Copyright 1998, Okidata, Division of OKI America, Inc. All rights reserved. See the OKIDATA Business Partner Exchange (BPX) for any updates to this material. (<http://bpx.okidata.com>)

Printer Unit (1 of 3)

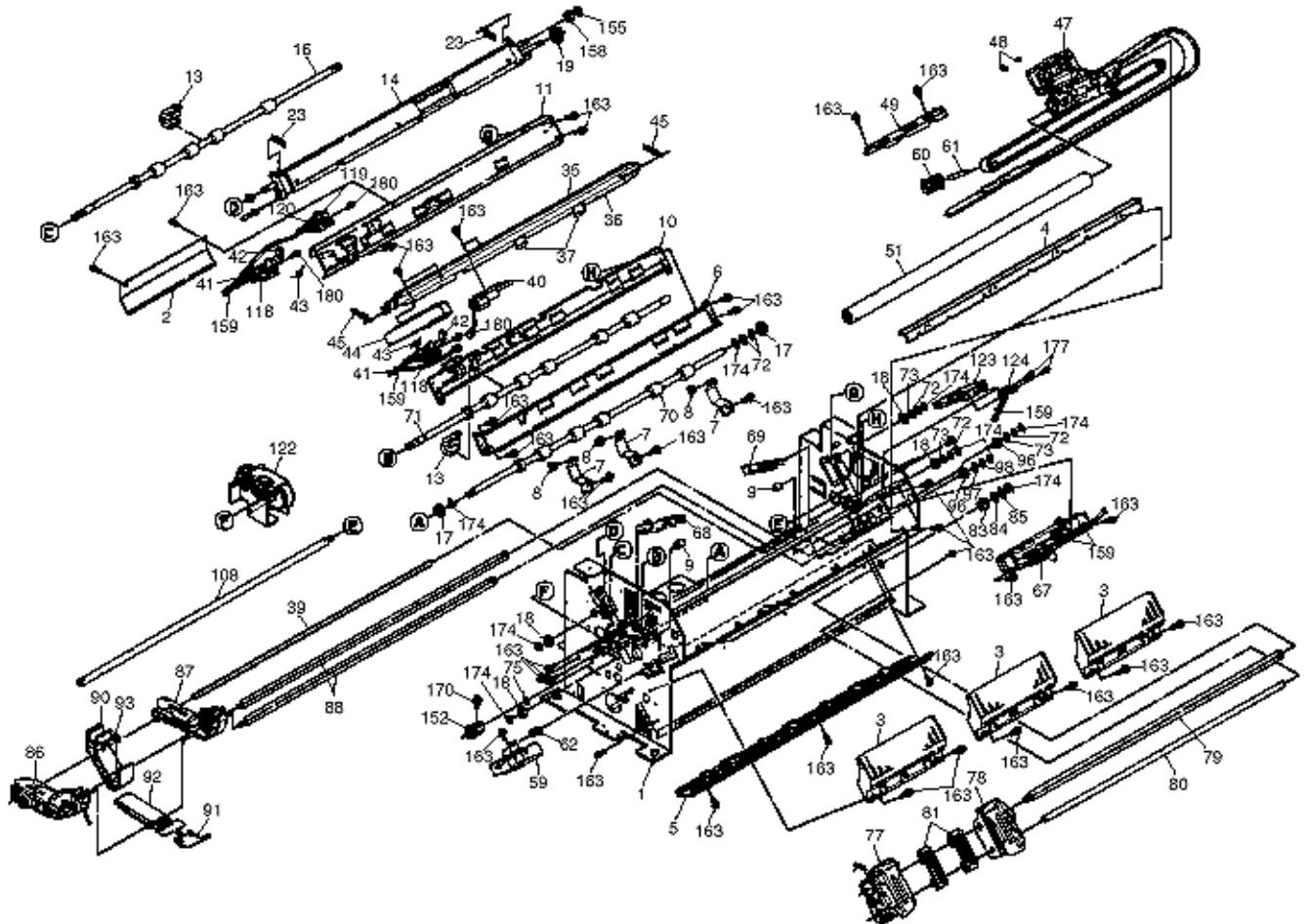

No.	OKI Part #	OKI-J Part #	Name	Qty Per Unit
1	40538101		Printhead - PM4410	1
2	40677101		Cover Assy-Lower	1
3	40677201		Cover Assy-Front	1
4				
5	40677401		Door Assy-Front	1
6	40768901		Plate-Front (Sticking)	1
7	40520201		Cover Assy-Access	1
8	40677601		Cover Assy-Side (L)	1
9	40677901		Cover Assy-Side (R)	1
10	40678301		Frame Assy-Rear	1
11	40678901		Frame-Opene (Sticking)	1
12	40520501		Cover-Rear (B)	1
13	40627701		Guide-Paper (B)	1
14	40738901		Cover-Blank (Lower)	1
15	40777901		Plate-earth (Cover-Rear)	1

16	40658201		Guide-Sheet	1
17	40498801		Spring-Pressure	3
18		3PP4053-3795P001	Pressure Roller Piece	3
19		4PB4044-1358P002	Stopper	2
20		4PB4035-4456P001	Bearing	2
21		4LP-6418-13	Ball Bearing RSF (12*8 W = 3.5)	4
22	40608401		Drive Gear C	1
23	40608301		Drive Bear B	3
24		4PP3520-1306P001	Idle Gear	3
25	40555001		Bearing - Metal (Bail)	2
26	40511801		Lever - Bail Lift (L)	1
27	40511901		Lever - Bail Lift (R)	1
28	40499601		Bail Assy	1
29	40791701		Spring (Bail)	2
30	40745501		Screw Stud	1
31	40609201		Bail Gear Bracket Assy	1
32	40608501		Bail Motor Bracket Assy	1
33		4PP4122-1285P001	Gear (Z19-Z52)	3
34		4LR-200494	Brake Gear	2
35	40500801		AG Sensor Lever Assy	1
36	40501201		AG Sensor Coil Assy	1
37	40513401		Sensor Lever Assy	2
38	40596601		Ribbon Guide Post	2
39	40533501		Head Cable Assy (FM50P)	1
40	40502901		Protector Ribbon Assy	1
41	40887501		Paper Width Sensor / Ribbon SW cord (with Sensor Cover and Tie Wrap)	1
42	40474701		Space Belt	1
43	40099101		Spring (Lift Arm)	2
44	40622101		Head Cable Guide	3
45	40503401		Guide Assy - Ribbon	1
46	40627101		SP Motor	1
47		4PB4044-4138P001	Idle Pulley	1
48		4PP4044-4155P001	Pulley Shaft	1
49		4PB4044-4357P001	Tension Spring	1
50	40507901		Space Motor Fan	1
51	40719201		Head Cooling Fan 2	1
52	40505501		Head Cooling Fan 1	1
53	40505801		PG Cooling Fan	1
54	40887401		Ribbon Assy - Feed	1
55	40458201		Motor - Ribbon	1
56		4PP4044-4232P001	Waved Washer	1
57	40630001		Drive Pulley	2
58		4PP4053-1321P001	LF Knob Gear	1
59	40588401		Pan Washer Feed	1
60	40507401		Washer	1
61		4PP4043-2590P001	Bush	2
62	40507601		Sprocket Assy (L)	1
63	40508101		Sprocket Assy (R)	1
64	40508301		Front Tractor Drive Gear	1
65		4PP4044-3489P001	Tractor Bush	4
66	40508401		Washer	1
67	40588501		Pan Washer Tractor Feed	1
68		5LR-123467	Sheet Guide	2
69	40508701		Sheet Feeder Assy (L) Rear	1
70	40509101		Sheet Feeder Assy (R) Rear	1
71	40778401		Rear Tractor Drive Gear	1
72		4PP4044-4268P001	Drive Gear B	1
73	40555501		Rear Tractor Bush	4
74	40509501		Washer	2

75	40588601		Pan Washer Tractor Rear	2
76	40509601		Center Guide (U)	1
77		3PP4043-2453P001	Center Guide Lower A	1
78	40509701		Guide Lower B - Center	1
79		4PP4043-2451P001	Friction Piece	1
80	40510501		Change Motor Bracket Assy	1
81	40511101		Tractor Change Lever	1
82	40794401		Tractor Change Lever SP	1
83	40615101		LF Motor	1
84		4LP-1313-33	Mini-pitch Belt	1
85	40511201		LF Gear	1
86	40511301		Tractor Change Gear	1
87		4LB-190700-A	Coil Spring	1
88		4PP4044-2800P001	Idle Roller	1
89	40511401		Pulley Assy - Idle	1
90	40534201		Bail Open SW/Front Tractor ONSW Cord	1
91	40141301		Slit Disk	1
92	40472401		Change Motor	3
93		4PP4044-3594P001	Idle Gear C	1
94		5LR-191324	Tractor Idle Gear	1
95	40512501		AG Motor Bracket Assy	1
96	40751101		PGA Printed Circuit Board Specs (only PGA PCB)	1
97	40534601		AG Slit Sensor Cord	1
98	40513901		JAM Sensor Assy	1
99	40533901		Paper JAM/Bail PE Sensor Cord	1
100	40646401		Knob Bracket Assy	1
101	40794501		Knob Cover	1
102	40646101		Idle Gear Shaft	1
103		4PP4043-2502P001	CSF Drive Gear	1
104		4PP4044-4193P001	Adjust Knob	1
105		SPP3-14SUS	Spring Pin	1
106		4PP4043-1895P001	Stacker Gear	1
107	40750801		PHA Printed Circuit Board Specs (with I/F Board and Bracket)	1
108	40533801		I/F Connection Cable HIROSEFC68	1
109	40750901		PRA Printed Circuit Board Specs (only Trunk Board)	1
110		2051001P1000	Interlock SW (AV14053)	1
111	40785101		Interlock SW Connection Cord	1
112	40514401		Cover Open Lever	1
113	40514501		Interlock Switch Lever	1
114	40552901		Interlock Switch Lever SP	1
115	40534501		Cover Open SW/Ribbon Sensor Rotation Cord	1
116	40798701		Locking Wire Saddle	10
117	40798702		Locking Wire Saddle	10
118	40652901		Continuous Form Cutter Code	1
119	40820601		Operation Panel Code (with Core)	1
120	40795002		One-Touch Bush	5
121		4LP-6693-3	Flat Cable Clip (FCC-225 19.1*76.2)	1
122		4LP-6401-B1	Tie Wrap (SHT18R-HS/TY-23M)	1
123		4LP-6342-2	Wire Bundle Clamp	2
124		3200561J0620	Brake Resistor (62 Ohms, 15W)	1
125		3200560J0120	Oscillation Resistor (12 Ohms, 40W)	2
126		4PB3529-5116P001	Tapping Screw	
127		4PB4013-3100P006	Cup Screw (S Tight M3)	
128		4PB4053-1883P002	Cup Screw with Washer	6
129	40750403		PMA Printed Circuit Board Specs (no ROM, with Bracket, Sheet & Fuse)	1

130				
131		540A2067T1632	Fuse (237-06.3)	1
132		540A23036M1502	Fuse (GGS5)	1
133	40751201		Control ROM Writing Specs	1
134	40751301		Font ROM Writing Specs	1
135				
136				
137	40750701		PDA Printed Circuit Board Specs (with Driver Board and Bracket)	1
138	40414001		Power Supply	1
139	40534401		Trunk Board Cord	1
140	40785001		SP Slit Sensor Cord	1
141	40751001		POA Printed Circuit Board Specs (only Operation Panel Board)	1
142	40742901		LDC Assy (with Cord and Core)	1
143	40533301		Nylon Connector Cord (13P)	1
144		4YS4011-4311P006	Nylon Connector Cord (12P)	1

Copyright 1998, Okidata, Division of OKI America, Inc. All rights reserved. See the OKIDATA Business Partner Exchange (BPX) for any updates to this material. (<http://bpx.okidata.com>)

Service Guide for PM4410 Chapter 8 Parts List

Printer Unit (2 of 3)

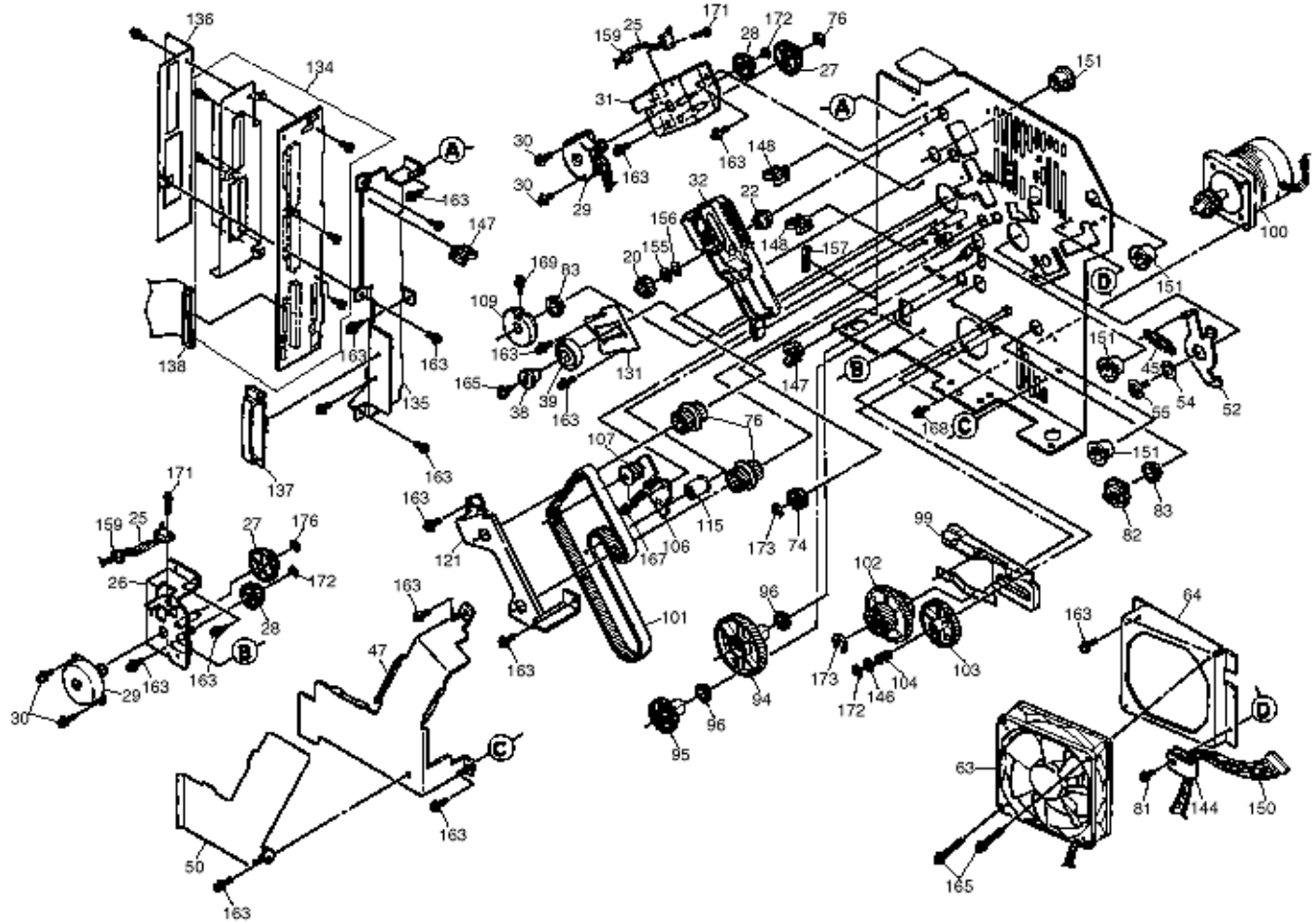

No.	OKI Part #	OKI-J Part #	Name	Qty Per Unit
1	40538101		Printhead - PM4410	1
2	40677101		Cover Assy-Lower	1
3	40677201		Cover Assy-Front	1
4				
5	40677401		Door Assy-Front	1
6	40768901		Plate-Front (Sticking)	1
7	40520201		Cover Assy-Access	1
8	40677601		Cover assy-Side (L)	1
9	40677901		Cover assy-Side (R)	1
10	40678301		Frame assy-Rear	1
11	40678901		Frame-Opepane (Sticking)	1
12	40520501		Cover-Rear (B)	1
13	40627701		Guide-Paper (B)	1
14	40738901		Cover-Brank (Lower)	1

15	40777901		Plate-earth (Cover-Rear)	1
16	40658201		Guide-Sheet	1
17	40498801		Spring-Pressure	3
18		3PP4053-3795P001	Pressure Roller Piece	3
19		4PB4044-1358P002	Stopper	2
20		4PB4035-4456P001	Bearing	2
21		4LP-6418-13	Ball Bearing RSF (12*8 W = 3.5)	4
22	40608401		Drive Gear C	1
23	40608301		Drive Bear B	3
24		4PP3520-1306P001	Idle Gear	3
25	40555001		Bearing - Metal (Bail)	2
26	40511801		Lever - Bail Lift (L)	1
27	40511901		Lever - Bail Lift (R)	1
28	40499601		Bail Assy	1
29	40791701		Spring (Bail)	2
30	40745501		Screw Stud	1
31	40609201		Bail Gear Bracket Assy	1
32	40608501		Bail Motor Bracket Assy	1
33		4PP4122-1285P001	Gear (Z19-Z52)	3
34		4LR-200494	Brake Gear	2
35	40500801		AG Sensor Lever Assy	1
36	40501201		AG Sensor Coil Assy	1
37	40513401		Sensor Lever Assy	2
38	40596601		Ribbon Guide Post	2
39	40533501		Head Cable Assy (FM50P)	1
40	40502901		Protector Ribbon Assy	1
41	40887501		Paper Width Sensor / Ribbon SW cord (with Sensor Cover and Tie Wrap)	1
42	40474701		Space Belt	1
43	40099101		Spring (Lift Arm)	2
44	40622101		Head Cable Guide	3
45	40503401		Guide Assy - Ribbon	1
46	40627101		SP Motor	1
47		4PB4044-4138P001	Idle Pulley	1
48		4PP4044-4155P001	Pulley Shaft	1
49		4PB4044-4357P001	Tension Spring	1
50	40507901		Space Motor Fan	1
51	40719201		Head Cooling Fan 2	1
52	40505501		Head Cooling Fan 1	1
53	40505801		PG Cooling Fan	1
54	40887401		Ribbon Assy - Feed	1
55	40458201		Motor - Ribbon	1
56		4PP4044-4232P001	Waved Washer	1
57	40630001		Drive Pulley	2
58		4PP4053-1321P001	LF Knob Gear	1
59	40588401		Pan Washer Feed	1
60	40507401		Washer	1
61		4PP4043-2590P001	Bush	2
62	40507601		Sprocket Assy (L)	1
63	40508101		Sprocket Assy (R)	1
64	40508301		Front Tractor Drive Gear	1
65		4PP4044-3489P001	Tractor Bush	4
66	40508401		Washer	1
67	40588501		Pan Washer Tractor Feed	1
68		5LR-123467	Sheet Guide	2
69	40508701		Sheet Feeder Assy (L) Rear	1
70	40509101		Sheet Feeder Assy (R) Rear	1
71	40778401		Rear Tractor Drive Gear	1
72		4PP4044-4268P001	Drive Gear B	1
73	40555501		Rear Tractor Bush	4

74	40509501		Washer	2
75	40588601		Pan Washer Tractor Rear	2
76	40509601		Center Guide (U)	1
77		3PP4043-2453P001	Center Guide Lower A	1
78	40509701		Guide Lower B - Center	1
79		4PP4043-2451P001	Friction Piece	1
80	40510501		Change Motor Bracket Assy	1
81	40511101		Tractor Change Lever	1
82	40794401		Tractor Change Lever SP	1
83	40615101		LF Motor	1
84		4LP-1313-33	Mini-pitch Belt	1
85	40511201		LF Gear	1
86	40511301		Tractor Change Gear	1
87		4LB-190700-A	Coil Spring	1
88		4PP4044-2800P001	Idle Roller	1
89	40511401		Pulley Assy - Idle	1
90	40534201		Bail Open SW/Front Tractor ONSW Cord	1
91	40141301		Slit Disk	1
92	40472401		Change Motor	3
93		4PP4044-3594P001	Idle Gear C	1
94		5LR-191324	Tractor Idle Gear	1
95	40512501		AG Motor Bracket Assy	1
96	40751101		PGA Printed Circuit Board Specs (only PGA PCB)	1
97	40534601		AG Slit Sensor Cord	1
98	40513901		JAM Sensor Assy	1
99	40533901		Paper JAM/Bail PE Sensor Cord	1
100	40646401		Knob Bracket Assy	1
101	40794501		Knob Cover	1
102	40646101		Idle Gear Shaft	1
103		4PP4043-2502P001	CSF Drive Gear	1
104		4PP4044-4193P001	Adjust Knob	1
105		SPP3-14SUS	Spring Pin	1
106		4PP4043-1895P001	Stacker Gear	1
107	40750801		PHA Printed Circuit Board Specs (with I/F Board and Bracket)	1
108	40533801		I/F Connection Cable HIROSEFC68	1
109	40750901		PRA Printed Circuit Board Specs (only Trunk Board)	1
110		2051001P1000	Interlock SW (AV14053)	1
111	40785101		Interlock SW Connection Cord	1
112	40514401		Cover Open Lever	1
113	40514501		Interlock Switch Lever	1
114	40552901		Interlock Switch Lever SP	1
115	40534501		Cover Open SW/Ribbon Sensor Rotation Cord	1
116	40798701		Locking Wire Saddle	10
117	40798702		Locking Wire Saddle	10
118	40652901		Continuous Form Cutter Code	1
119	40820601		Operation Panel Code (with Core)	1
120	40795002		One-Touch Bush	5
121		4LP-6693-3	Flat Cable Clip (FCC-225 19.1*76.2)	1
122		4LP-6401-B1	Tie Wrap (SHT18R-HS/TY-23M)	1
123		4LP-6342-2	Wire Bundle Clamp	2
124		3200561J0620	Brake Resistor (62 Ohms, 15W)	1
125		3200560J0120	Oscillation Resistor (12 Ohms, 40W)	2
126		4PB3529-5116P001	Tapping Screw	
127		4PB4013-3100P006	Cup Screw (S Tight M3)	
128		4PB4053-1883P002	Cup Screw with Washer	6

129	40750403		PMA Printed Circuit Board Specs (no ROM, with Bracket, Sheet & Fuse)	1
130				
131		540A2067T1632	Fuse (237-06.3)	1
132		540A23036M1502	Fuse (GGS5)	1
133	40751201		Control ROM Writing Specs	1
134	40751301		Font ROM Writing Specs	1
135				
136				
137	40750701		PDA Printed Circuit Board Specs (with Driver Board and Bracket)	1
138	40414001		Power Supply	1
139	40534401		Trunk Board Cord	1
140	40785001		SP Slit Sensor Cord	1
141	40751001		POA Printed Circuit Board Specs (only Operation Panel Board)	1
142	40742901		LDC Assy (with Cord and Core)	1
143	40533301		Nylon Connector Cord (13P)	1
144		4YS4011-4311P006	Nylon Connector Cord (12P)	1

Copyright 1998, Okidata, Division of OKI America, Inc. All rights reserved. See the OKIDATA Business Partner Exchange (BPX) for any updates to this material. (<http://bpx.okidata.com>)

Printer Unit (3 of 3)

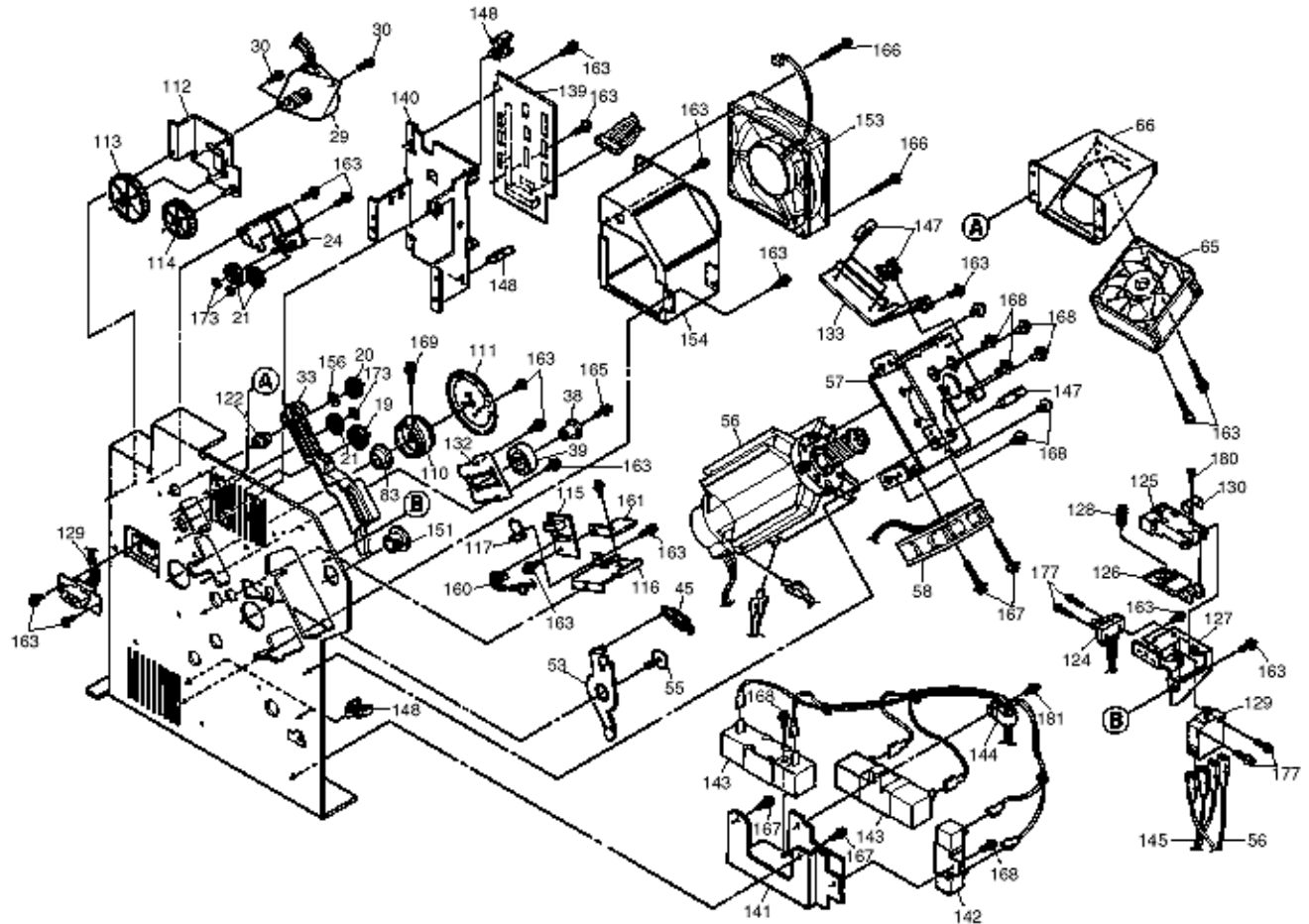

No.	OKI Part #	OKI-J Part #	Name	Qty Per Unit
1	40538101		Printhead - PM4410	1
2	40677101		Cover Assy-Lower	1
3	40677201		Cover Assy-Front	1
4				
5	40677401		Door Assy-Front	1
6	40768901		Plate-Front (Sticking)	1
7	40520201		Cover Assy-Access	1
8	40677601		Cover assy-Side (L)	1
9	40677901		Cover assy-Side (R)	1
10	40678301		Frame assy-Rear	1
11	40678901		Frame-Opepane (Sticking)	1
12	40520501		Cover-Rear (B)	1
13	40627701		Guide-Paper (B)	1
14	40738901		Cover-Blank (Lower)	1
15	40777901		Plate-earth (Cover-Rear)	1

16	40658201		Guide-Sheet	1
17	40498801		Spring-Pressure	3
18		3PP4053-3795P001	Pressure Roller Piece	3
19		4PB4044-1358P002	Stopper	2
20		4PB4035-4456P001	Bearing	2
21		4LP-6418-13	Ball Bearing RSF (12*8 W = 3.5)	4
22	40608401		Drive Gear C	1
23	40608301		Drive Bear B	3
24		4PP3520-1306P001	Idle Gear	3
25	40555001		Bearing - Metal (Bail)	2
26	40511801		Lever - Bail Lift (L)	1
27	40511901		Lever - Bail Lift (R)	1
28	40499601		Bail Assy	1
29	40791701		Spring (Bail)	2
30	40745501		Screw Stud	1
31	40609201		Bail Gear Bracket Assy	1
32	40608501		Bail Motor Bracket Assy	1
33		4PP4122-1285P001	Gear (Z19-Z52)	3
34		4LR-200494	Brake Gear	2
35	40500801		AG Sensor Lever Assy	1
36	40501201		AG Sensor Coil Assy	1
37	40513401		Sensor Lever Assy	2
38	40596601		Ribbon Guide Post	2
39	40533501		Head Cable Assy (FM50P)	1
40	40502901		Protector Ribbon Assy	1
41	40887501		Paper Width Sensor / Ribbon SW cord (with Sensor Cover and Tie Wrap)	1
42	40474701		Space Belt	1
43	40099101		Spring (Lift Arm)	2
44	40622101		Head Cable Guide	3
45	40503401		Guide Assy - Ribbon	1
46	40627101		SP Motor	1
47		4PB4044-4138P001	Idle Pulley	1
48		4PP4044-4155P001	Pulley Shaft	1
49		4PB4044-4357P001	Tension Spring	1
50	40507901		Space Motor Fan	1
51	40719201		Head Cooling Fan 2	1
52	40505501		Head Cooling Fan 1	1
53	40505801		PG Cooling Fan	1
54	40887401		Ribbon Assy - Feed	1
55	40458201		Motor - Ribbon	1
56		4PP4044-4232P001	Waved Washer	1
57	40630001		Drive Pulley	2
58		4PP4053-1321P001	LF Knob Gear	1
59	40588401		Pan Washer Feed	1
60	40507401		Washer	1
61		4PP4043-2590P001	Bush	2
62	40507601		Sprocket Assy (L)	1
63	40508101		Sprocket Assy (R)	1
64	40508301		Front Tractor Drive Gear	1
65		4PP4044-3489P001	Tractor Bush	4
66	40508401		Washer	1
67	40588501		Pan Washer Tractor Feed	1
68		5LR-123467	Sheet Guide	2
69	40508701		Sheet Feeder Assy (L) Rear	1
70	40509101		Sheet Feeder Assy (R) Rear	1
71	40778401		Rear Tractor Drive Gear	1
72		4PP4044-4268P001	Drive Gear B	1
73	40555501		Rear Tractor Bush	4
74	40509501		Washer	2

75	40588601		Pan Washer Tractor Rear	2
76	40509601		Center Guide (U)	1
77		3PP4043-2453P001	Center Guide Lower A	1
78	40509701		Guide Lower B - Center	1
79		4PP4043-2451P001	Friction Piece	1
80	40510501		Change Motor Bracket Assy	1
81	40511101		Tractor Change Lever	1
82	40794401		Tractor Change Lever SP	1
83	40615101		LF Motor	1
84		4LP-1313-33	Mini-pitch Belt	1
85	40511201		LF Gear	1
86	40511301		Tractor Change Gear	1
87		4LB-190700-A	Coil Spring	1
88		4PP4044-2800P001	Idle Roller	1
89	40511401		Pulley Assy - Idle	1
90	40534201		Bail Open SW/Front Tractor ONSW Cord	1
91	40141301		Slit Disk	1
92	40472401		Change Motor	3
93		4PP4044-3594P001	Idle Gear C	1
94		5LR-191324	Tractor Idle Gear	1
95	40512501		AG Motor Bracket Assy	1
96	40751101		PGA Printed Circuit Board Specs (only PGA PCB)	1
97	40534601		AG Slit Sensor Cord	1
98	40513901		JAM Sensor Assy	1
99	40533901		Paper JAM/Bail PE Sensor Cord	1
100	40646401		Knob Bracket Assy	1
101	40794501		Knob Cover	1
102	40646101		Idle Gear Shaft	1
103		4PP4043-2502P001	CSF Drive Gear	1
104		4PP4044-4193P001	Adjust Knob	1
105		SPP3-14SUS	Spring Pin	1
106		4PP4043-1895P001	Stacker Gear	1
107	40750801		PHA Printed Circuit Board Specs (with I/F Board and Bracket)	1
108	40533801		I/F Connection Cable HIROSEFC68	1
109	40750901		PRA Printed Circuit Board Specs (only Trunk Board)	1
110		2051001P1000	Interlock SW (AV14053)	1
111	40785101		Interlock SW Connection Cord	1
112	40514401		Cover Open Lever	1
113	40514501		Interlock Switch Lever	1
114	40552901		Interlock Switch Lever SP	1
115	40534501		Cover Open SW/Ribbon Sensor Rotation Cord	1
116	40798701		Locking Wire Saddle	10
117	40798702		Locking Wire Saddle	10
118	40652901		Continuous Form Cutter Code	1
119	40820601		Operation Panel Code (with Core)	1
120	40795002		One-Touch Bush	5
121		4LP-6693-3	Flat Cable Clip (FCC-225 19.1*76.2)	1
122		4LP-6401-B1	Tie Wrap (SHT18R-HS/TY-23M)	1
123		4LP-6342-2	Wire Bundle Clamp	2
124		3200561J0620	Brake Resistor (62 Ohms, 15W)	1
125		3200560J0120	Oscillation Resistor (12 Ohms, 40W)	2
126		4PB3529-5116P001	Tapping Screw	
127		4PB4013-3100P006	Cup Screw (S Tight M3)	
128		4PB4053-1883P002	Cup Screw with Washer	6
129	40750403		PMA Printed Circuit Board Specs (no ROM, with Bracket, Sheet & Fuse)	1

130				
131		540A2067T1632	Fuse (237-06.3)	1
132		540A23036M1502	Fuse (GGS5)	1
133	40751201		Control ROM Writing Specs	1
134	40751301		Font ROM Writing Specs	1
135				
136				
137	40750701		PDA Printed Circuit Board Specs (with Driver Board and Bracket)	1
138	40414001		Power Supply	1
139	40534401		Trunk Board Cord	1
140	40785001		SP Slit Sensor Cord	1
141	40751001		POA Printed Circuit Board Specs (only Operation Panel Board)	1
142	40742901		LDC Assy (with Cord and Core)	1
143	40533301		Nylon Connector Cord (13P)	1
144		4YS4011-4311P006	Nylon Connector Cord (12P)	1

Copyright 1998, Okidata, Division of OKI America, Inc. All rights reserved. See the OKIDATA Business Partner Exchange (BPX) for any updates to this material. (<http://bpx.okidata.com>)

Carriage Assembly

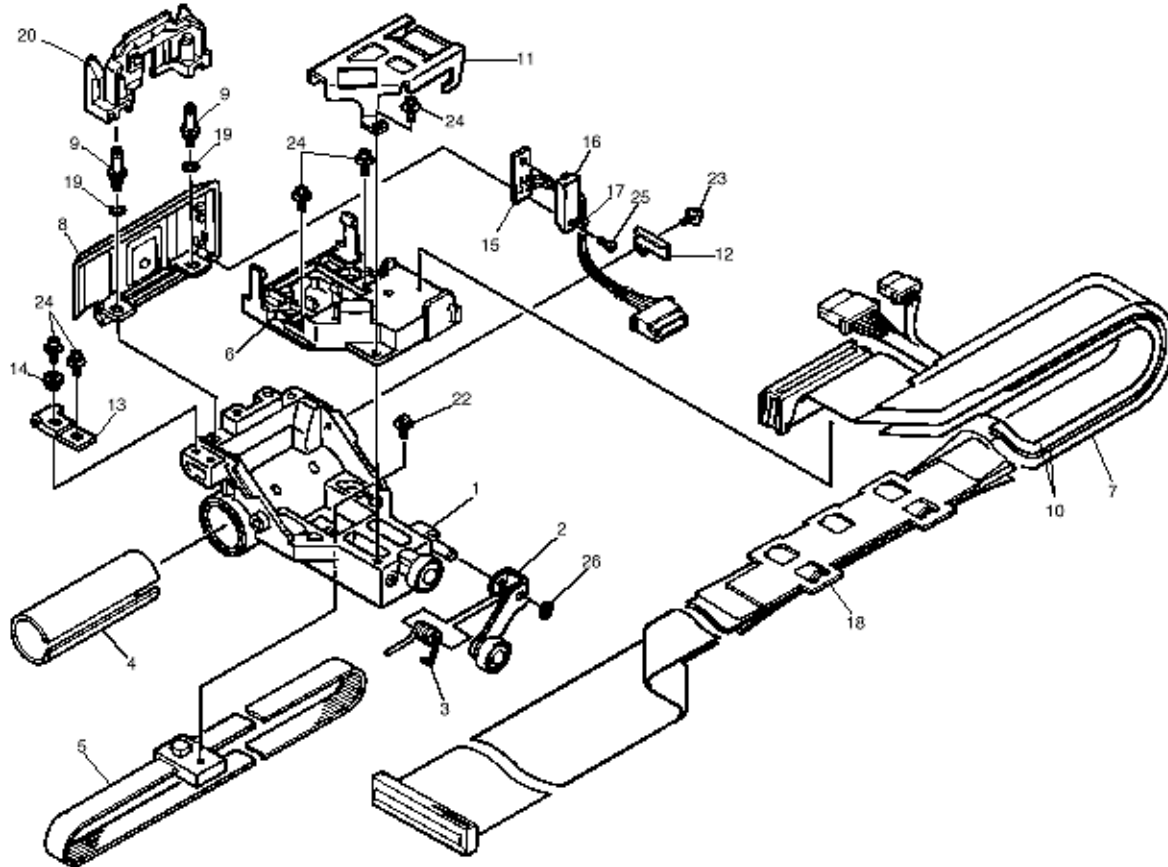

No.	Parts No.	Name	Qty	Remarks
1	40502001	Frame Carriage	1	
2	40547701	Bias Roller Assy	1	
3	51706401	Spring	1	
4	40474701	Felt	1	
5		Space Belt	1	
6		Guide - Connector	1	
7	40533501	Connection Cord - Flat	1	
8	40502901	Protector Ribbon Assy	1	
9	40596601	Ribbon Guide Post	1	
10	40622101	Head Cable Guide	1	
11		Cable Holder	1	
12		Clamp - Cord	1	
13		AG Plate	1	
14		Hexagon Eccentric Shoulder	1	
15		Connection Cord Paper Width Sensor / Dislocated Ribbon SW	1	
16		Cover - Sensor	1	
17		SHT18R-HS/TY-23M Tie Wrap	1	

18		Clamp Cable	1	
19	40503401	Washer	1	
20		Guide Assy - Ribbon	1	
21				
22-24		Screw	1	
25		Tapping Screw	1	
26		E-Ring	1	

Copyright 1998, Okidata, Division of OKI America, Inc. All rights reserved. See the OKIDATA Business Partner Exchange (BPX) for any updates to this material. (<http://bpx.okidata.com>)

Knob Assembly

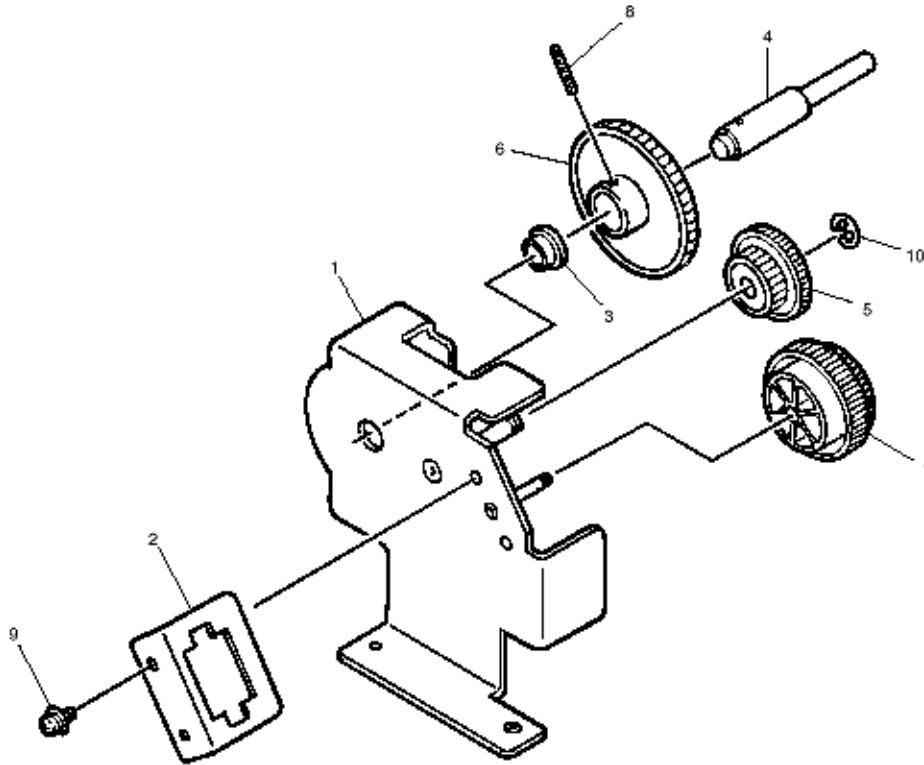

No.	Parts No.	Name	Qty	Remarks
1	40646401	Bracket Assy - Knob	1	
2	40794501	Knob Cover	1	
3	51609701	Bush	1	
4	40646101	Idle Gear Shaft	1	
5	51240201	Gear (Z19-52)	1	
6	51241001	CSF Drive Gear	1	
7	51902701	Adjust Knob	1	
8	54004201	Spring Pin	1	
9		Screw	1	
10		E Ring	1	

Ribbon Assembly

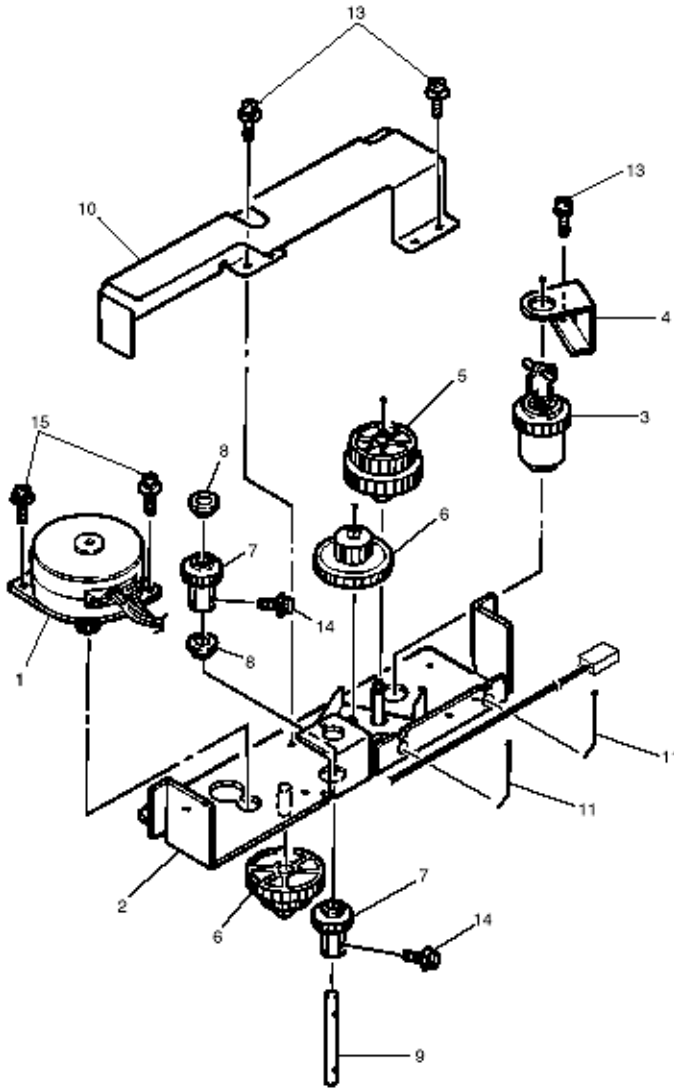

No.	Parts No.	Name	Qty	Remarks
1	40458201	Motor - Ribbon	1	
2		Frame Assy - Ribbon Feed	1	
3		Ribbon Drive Gear Assy	1	
4		Drive Gear Bracket	1	
5		Idle Gear	1	
6		Ribbon Feed Gear	1	
7	51218101	Stacker Gear	1	
8	51609701	Bush	1	
9		Shaft - Idle	1	
10		Holder - Ribbon Bracket	1	
11		SHT18R-HS/TY-23M Tie Wrap	1	
12			1	

13		Screw	1	
14		Screw	1	
15		Screw	1	

Copyright 1998, Okidata, Division of OKI America, Inc. All rights reserved. See the OKIDATA Business Partner Exchange (BPX) for any updates to this material. (<http://bpx.okidata.com>)

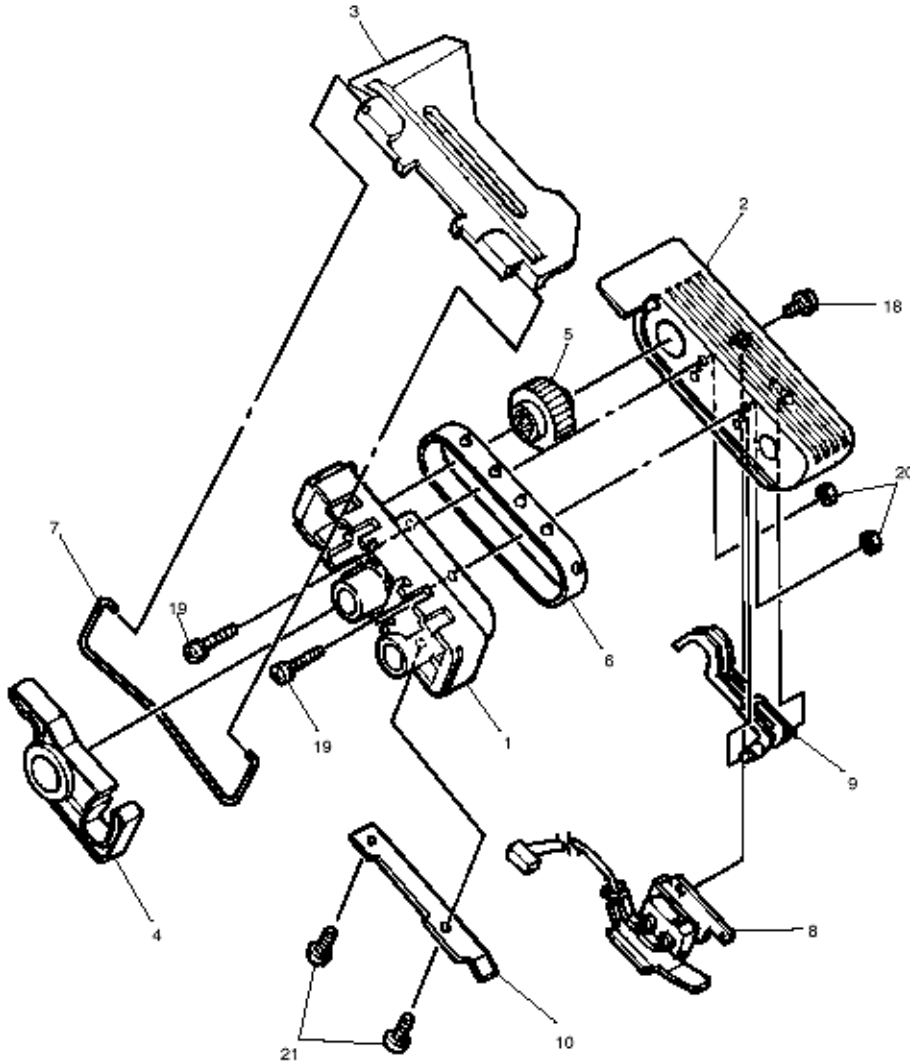
Sprocket Assembly (L)

Sprocket Assembly - L - 40507601

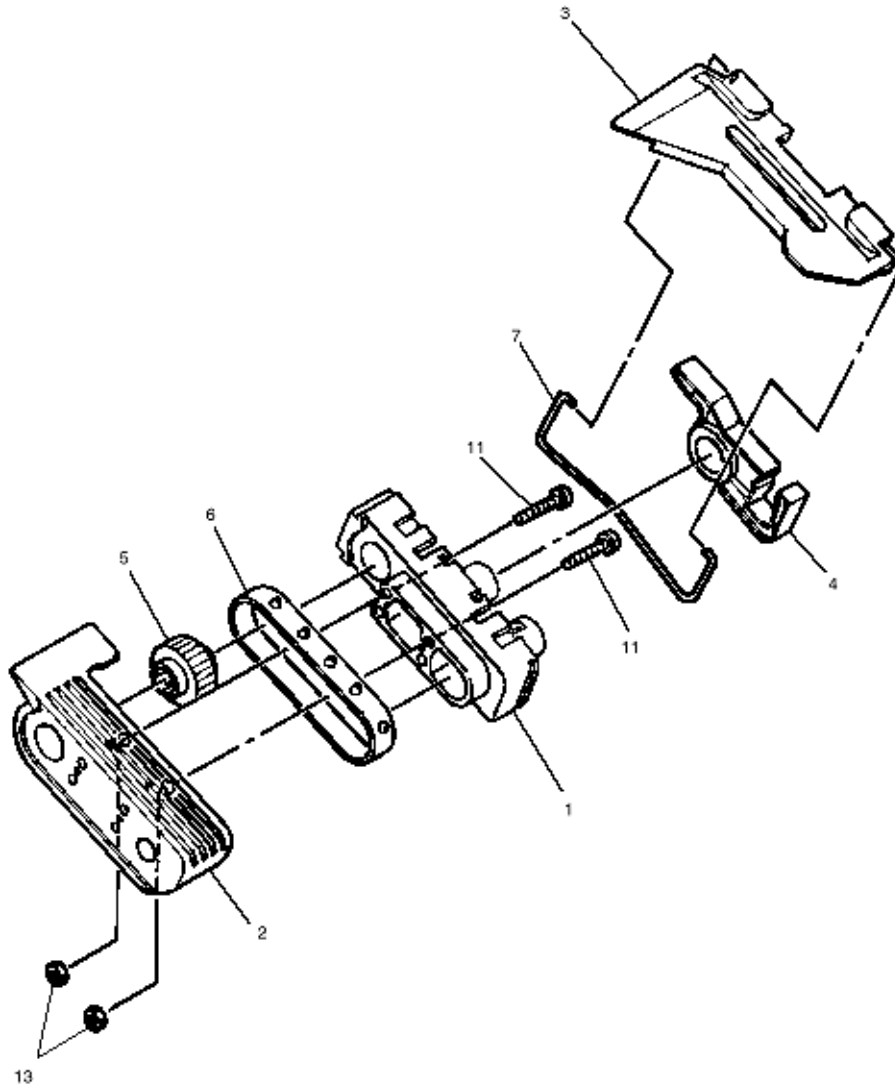
Sprocket Assembly (R)

Sprocket Assy (R) - 40508101

Sheet Feeder Assembly (L) Rear

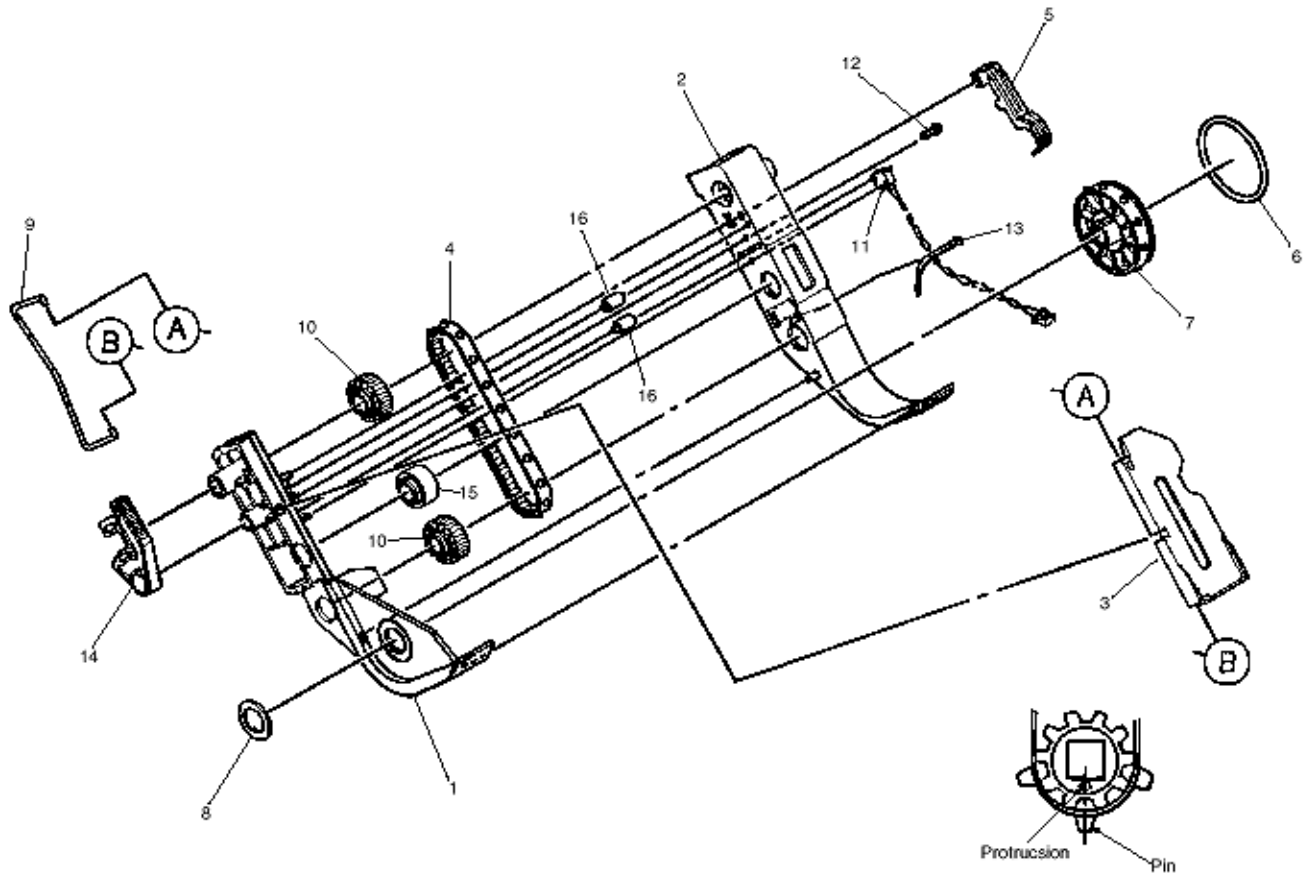

Note . Assembly should be done, meeting the protrusion 10 to the pin 4.

Sheet Feeder Assembly (L) Rear - P/N 40508701

Sheet Feeder Assembly (R) Rear

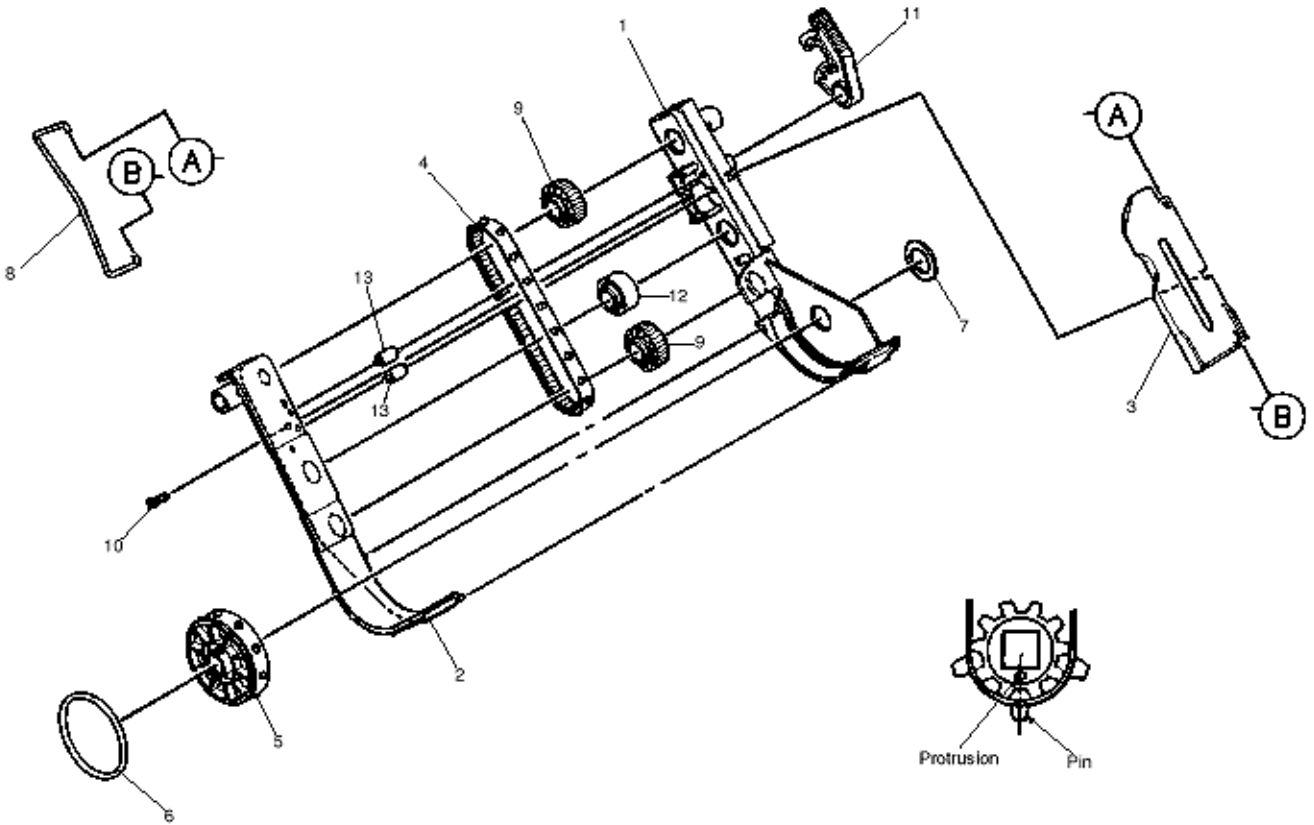

Note : Assembly should be done, meeting the protrusion 6 to the pin 4.

Sheet Feeder Assembly (R) Rear - P/N 40509101

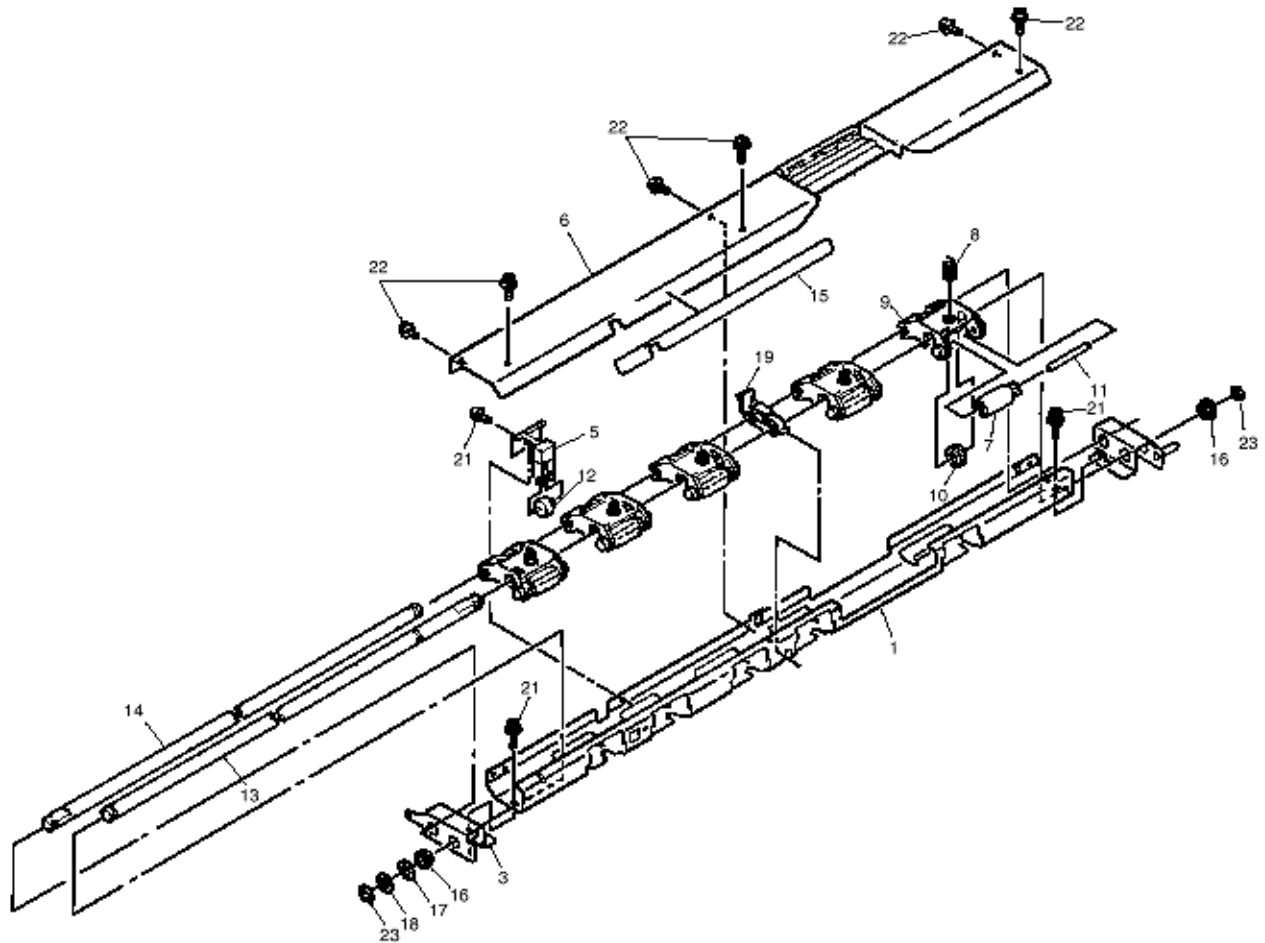
Bail Assembly

Bail Assembly - P/N 40499601

Lower Cover Assembly

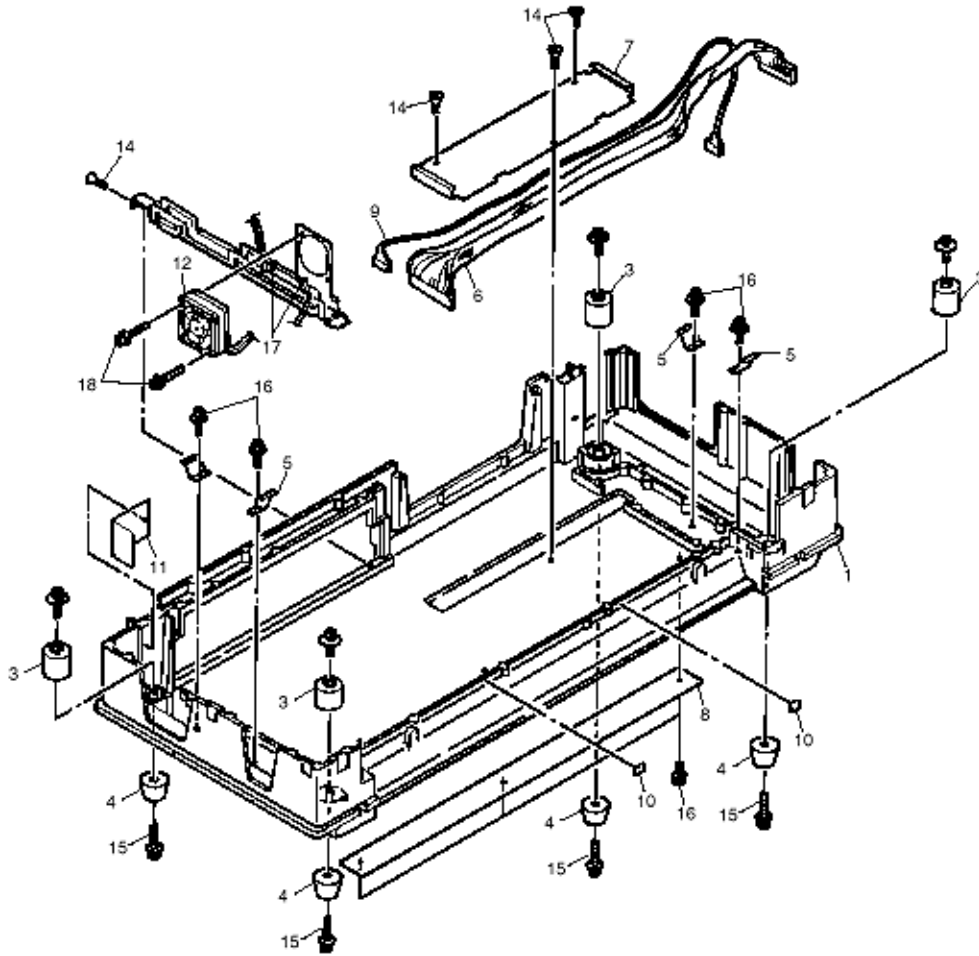

Lower Cover Assy - P/N 40677101

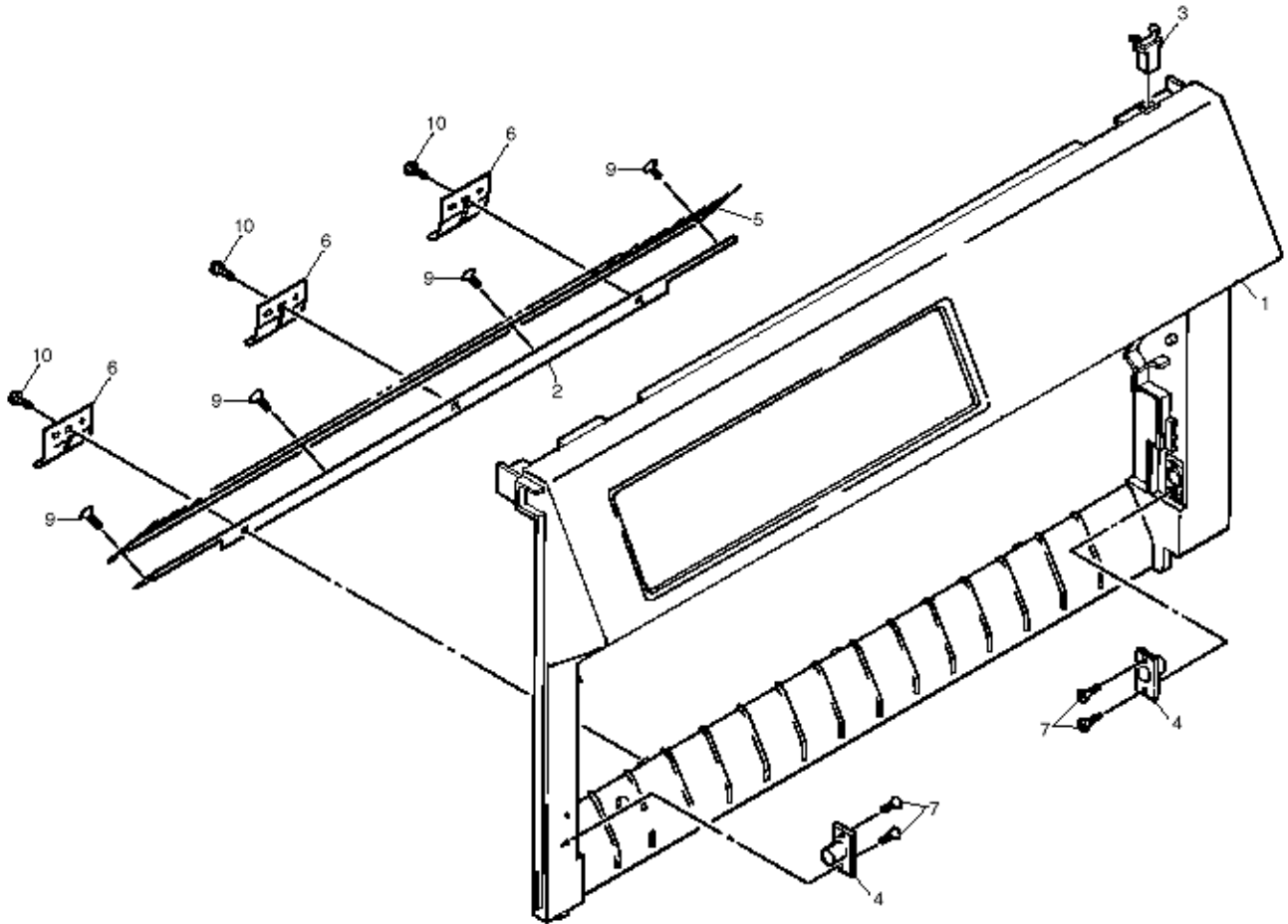
Front Cover Assembly

Front Cover Assembly - P/N 40677201

Service Guide for PM4410
Chapter 8 Parts List

Rear Cover Assembly

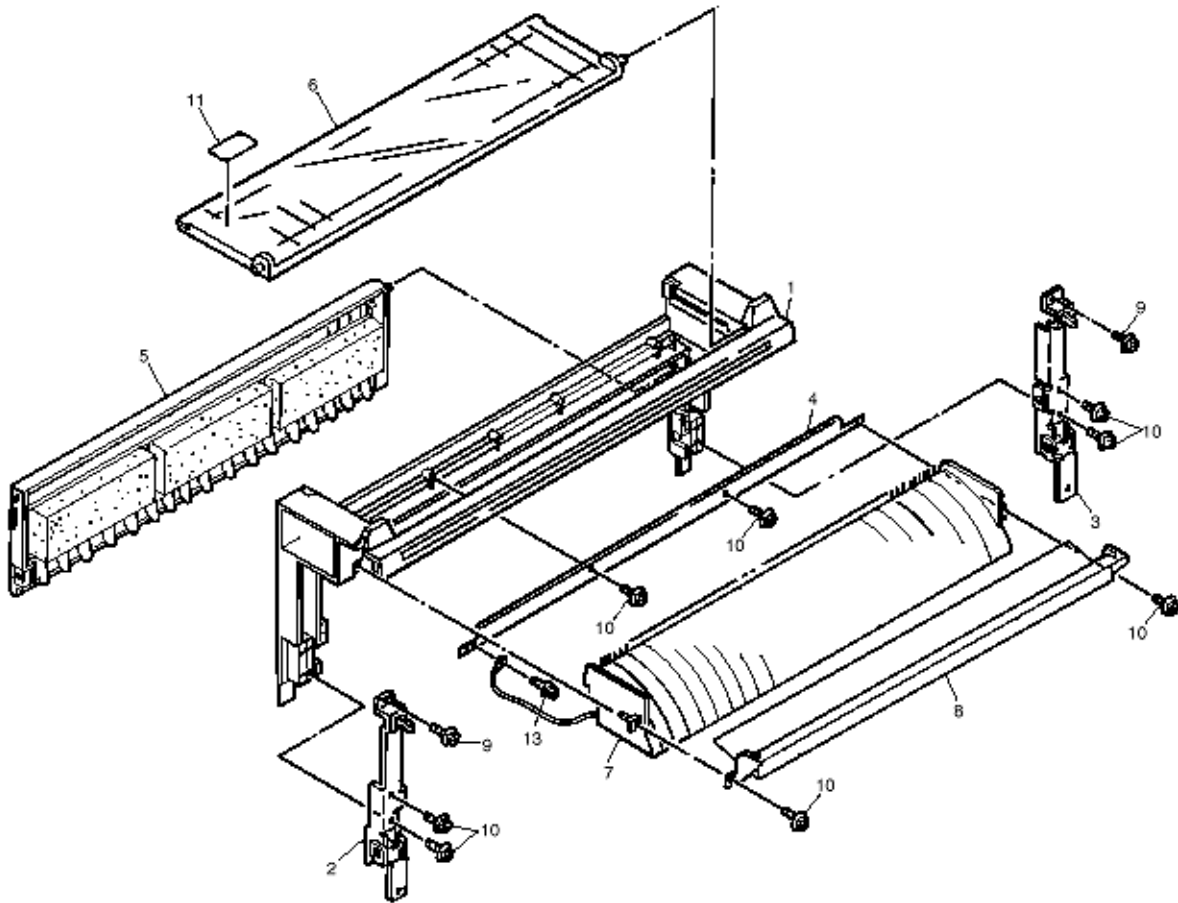

Rear Cover Assembly - P/N 40678301

Service Guide for PM4410 Chapter 8 Parts List

Access Cover

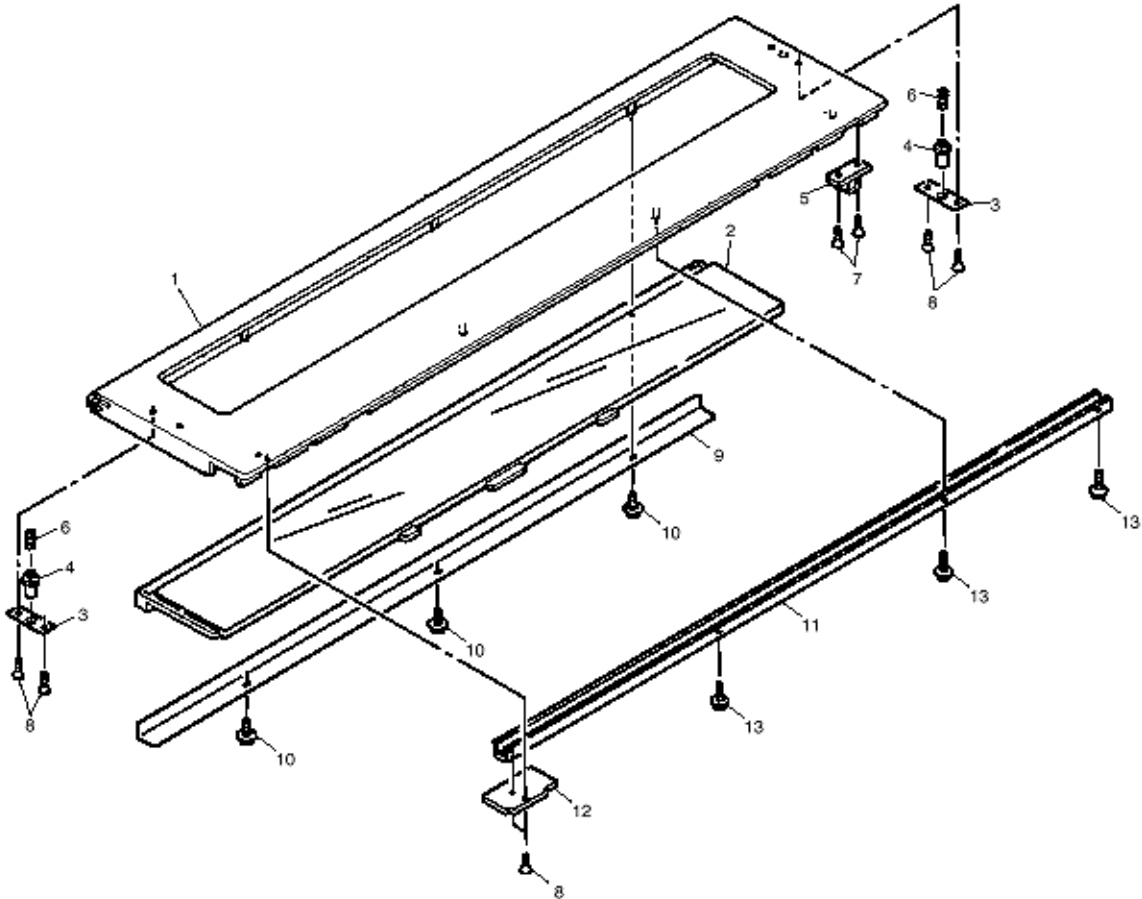

Access Cover - P/N 40520201

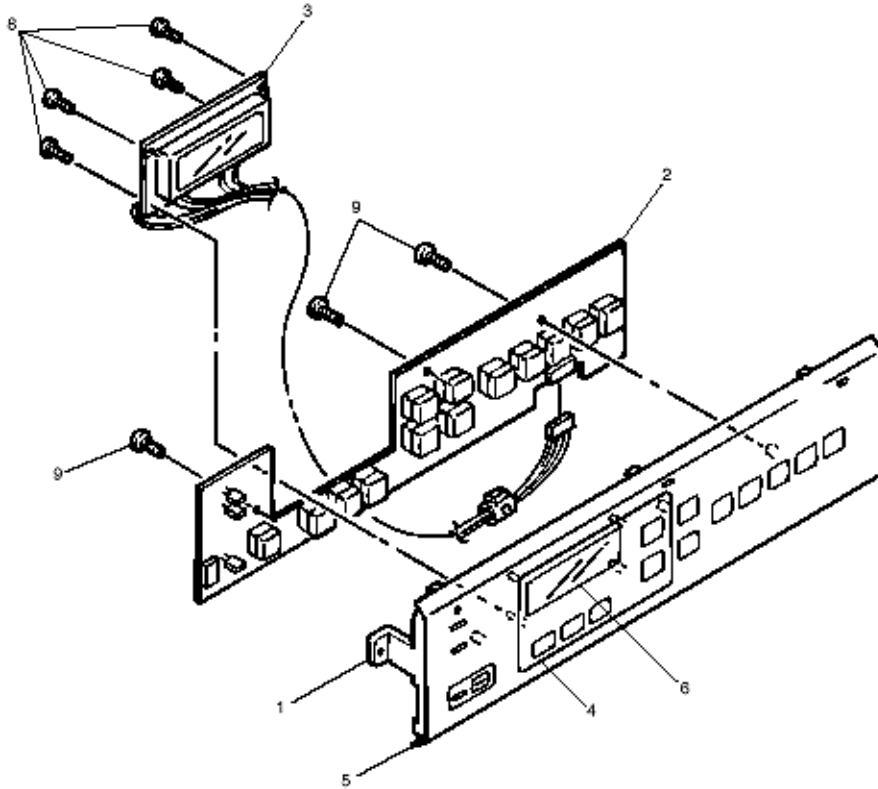
Frame Assembly - OpePane

Frame Assembly OpePane - P/N - 40755801

Service Guide for PM4410 Chapter 8 Parts List

PMA/PDA PCB Assembly

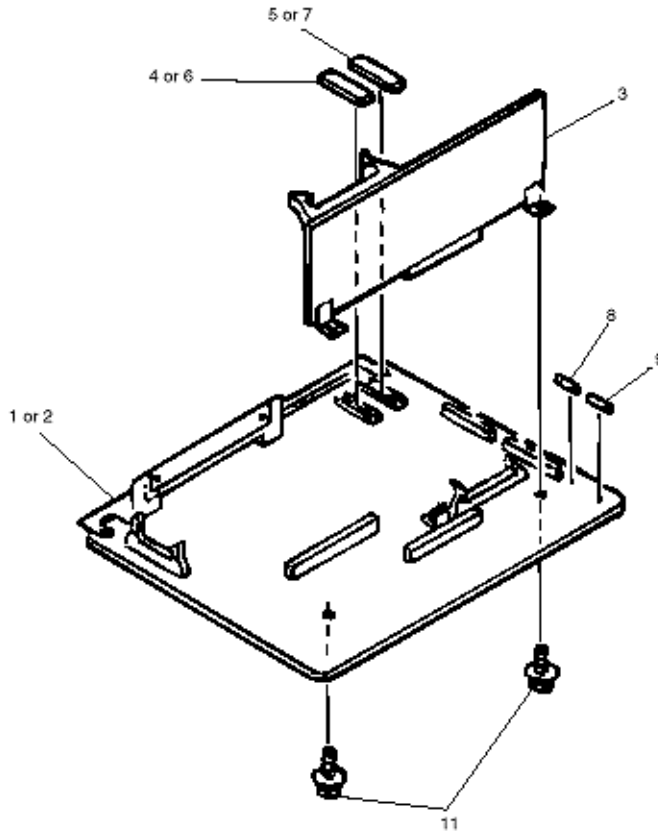

No.	Parts No.	Name	Qty	Remarks
1	40750403	PMA-PCB Without ROM	1	
2	40750402	PMA-PCB	1	
3	40750701	PDA-PCB	1	
4	40751201	Control ROM Writing Specifications	1	
5	40751301	Font ROM Writing Specifications	1	
6		Control ROM Writing Specifications	1	
7		Font ROM Writing Specifications	1	
8	56306132	Fuse (237-06.3)	1	
9	56305901	Fuse (GGS5)	1	
10			1	
11		Screw	1	

(1) Circuit board PMA (Control)

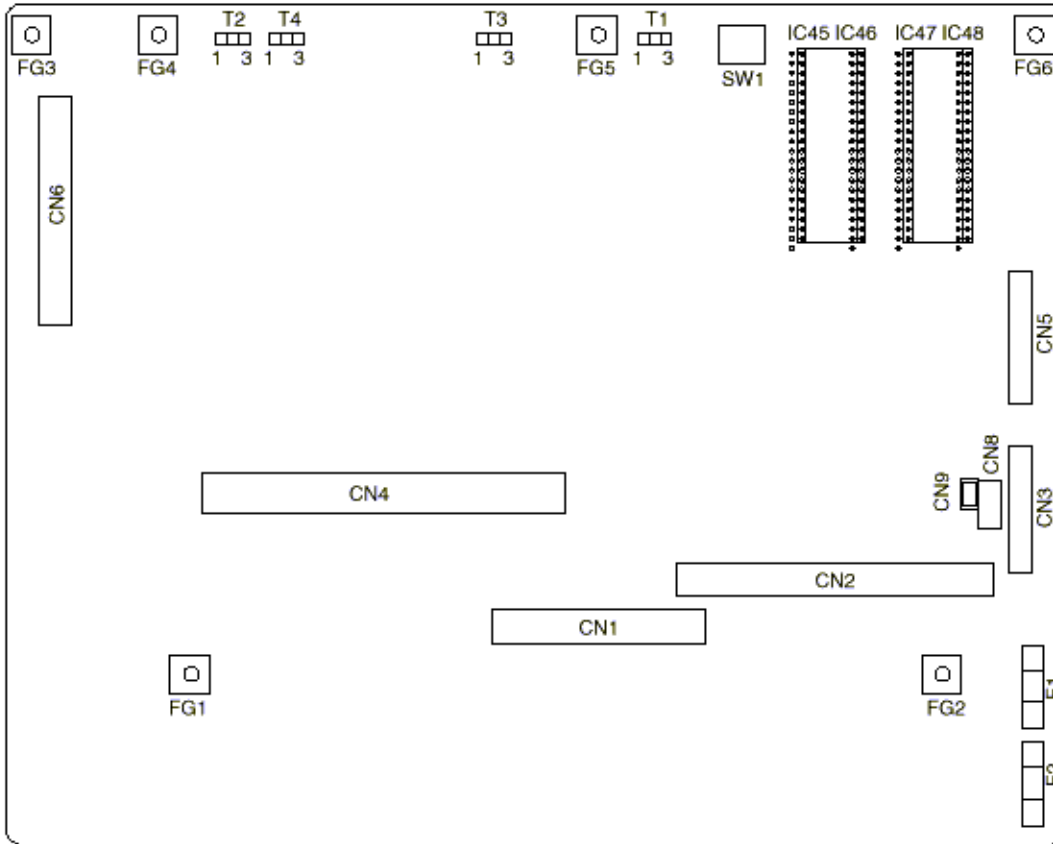

Short Plug	Setting	Default
	1-2 When either PGROM or CGROM is 8 or 16Mbit mask ROM.	1-2
	2-3 When either PGROM or CGROM is 32Mbit mask ROM.	1-2
	Centronics I/F (Pin No. 35)	2-3
	1-2 In IEEE 1284 mode.	2-3
	2-3 Compatible with PM3410.	2-3

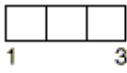
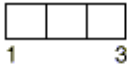
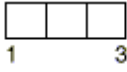
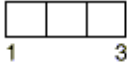
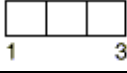
<p style="text-align: center;">T3</p> 	1-2	When the PGROM is EPROM (IC46)	1-2
<p style="text-align: center;">T3</p> 	2-3	When the PGROM is mask ROM (IC45).	1-2
<p style="text-align: center;">T4</p> 	Centronics I/F (Pin No. 18)		2-3
<p style="text-align: center;">T4</p> 	1-2	In IEEE 1284 mode.	2-3
<p style="text-align: center;">T4</p> 	2-3	Compatible with PM3410.	2-3

Copyright 1998, Okidata, Division of OKI America, Inc. All rights reserved. See the OKIDATA Business Partner Exchange (BPX) for any updates to this material. (<http://bpx.okidata.com>)

(2) Circuit board PDA (Driver)

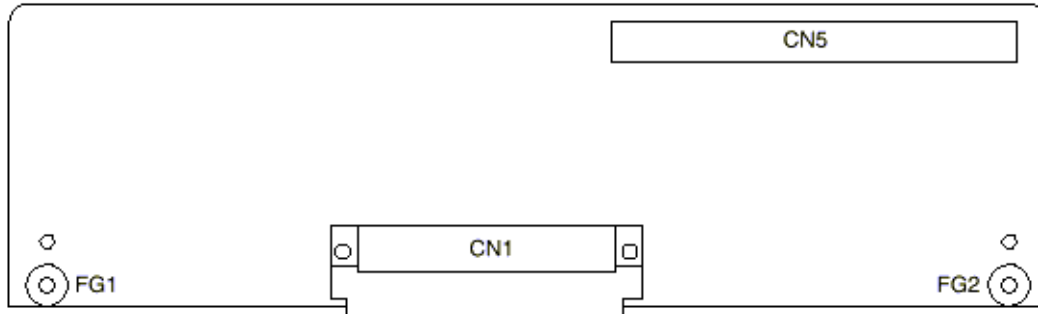

Copyright 1998, Okidata, Division of OKI America, Inc. All rights reserved. See the OKIDATA Business Partner Exchange (BPX) for any updates to this material. (<http://bpx.okidata.com>)



Service Guide for PM4410 Chapter A PCB Layout

(3) Circuit board POA (Operation Panel)

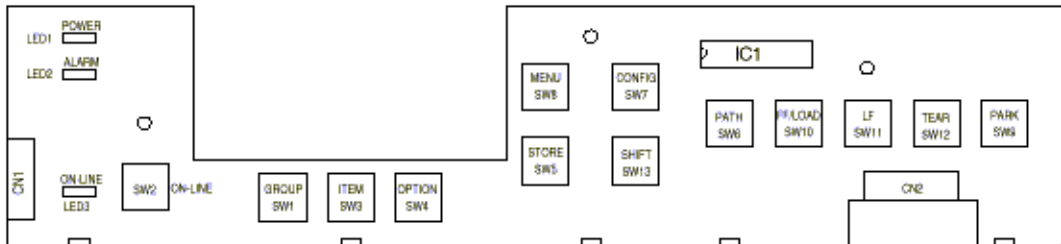

Copyright 1998, Okidata, Division of OKI America, Inc. All rights reserved. See the OKIDATA Business Partner Exchange (BPX) for any updates to this material. (<http://bpx.okidata.com>)

(4) Circuit board PHA (Interface)

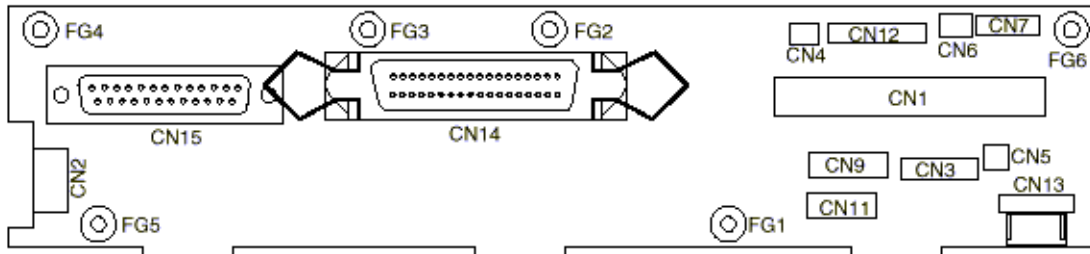

Copyright 1998, Okidata, Division of OKI America, Inc. All rights reserved. See the OKIDATA Business Partner Exchange (BPX) for any updates to this material. (<http://bpx.okidata.com>)

(5) Circuit board PRA (Connection)

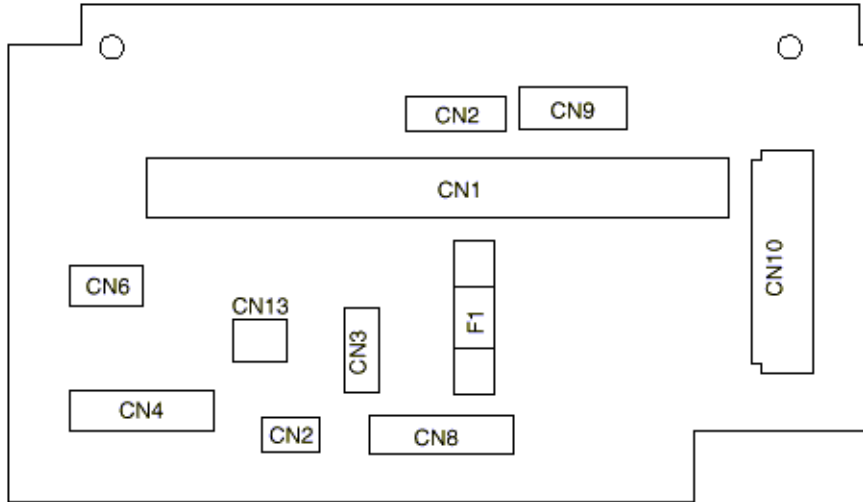



Service Guide for PM4410 Chapter A PCB Layout

(6) Circuit board PGA (Sensor)

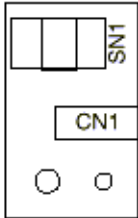

Copyright 1998, Okidata, Division of OKI America, Inc. All rights reserved. See the OKIDATA Business Partner Exchange (BPX) for any updates to this material. (<http://bpx.okidata.com>)



Service Guide for PM4410

Chapter B RS-232C Serial Interface Board

1. General

This section describes the operation of the RS-232C Serial Interface board installed in the Printer as an standard, using a start-stop synchronization and serial communications circuit. This serial interface board is capable of transmitting and receiving simultaneously at speeds up to 19,200 bits per second. Two protocols are available: printer Ready/Busy and X-ON/X-OFF modes.

This serial interface board has been installed in your Pacemark 4410.

Copyright 1998, Okidata, Division of OKI America, Inc. All rights reserved. See the OKIDATA Business Partner Exchange (BPX) for any updates to this material. (<http://bpx.okidata.com>)



Service Guide for PM4410
Chapter B RS-232C Serial Interface Board

2. Operation Description

2.1 Element Description

2.2 Circuit Description

2.3 Local Test

Copyright 1998, Okidata, Division of OKI America, Inc. All rights reserved. See the OKIDATA Business Partner Exchange (BPX) for any updates to this material. (<http://bpx.okidata.com>)



2.1 Element Description

(1) 80C51 with MASK ROM

An eight-bit microprocessor controller that controls the following:

- a) Serial interface protocol and data transfer through a serial port.
- b) Message buffer.
- c) Transmission of parallel data to the printer.

(2) SN75189

An RS-232C standard line receiver

(3) SN75188

An RS-232C standard line driver.

(4) 2764

An 8 kbyte ROM that contains the serial interface control program.

(5) HM6264

An 8192-byte static RAM used as a message buffer.



Service Guide for PM4410 Chapter B RS-232C Serial Interface Board

2.2 Circuit Description

A block diagram is shown in Figure B-2-1 below.

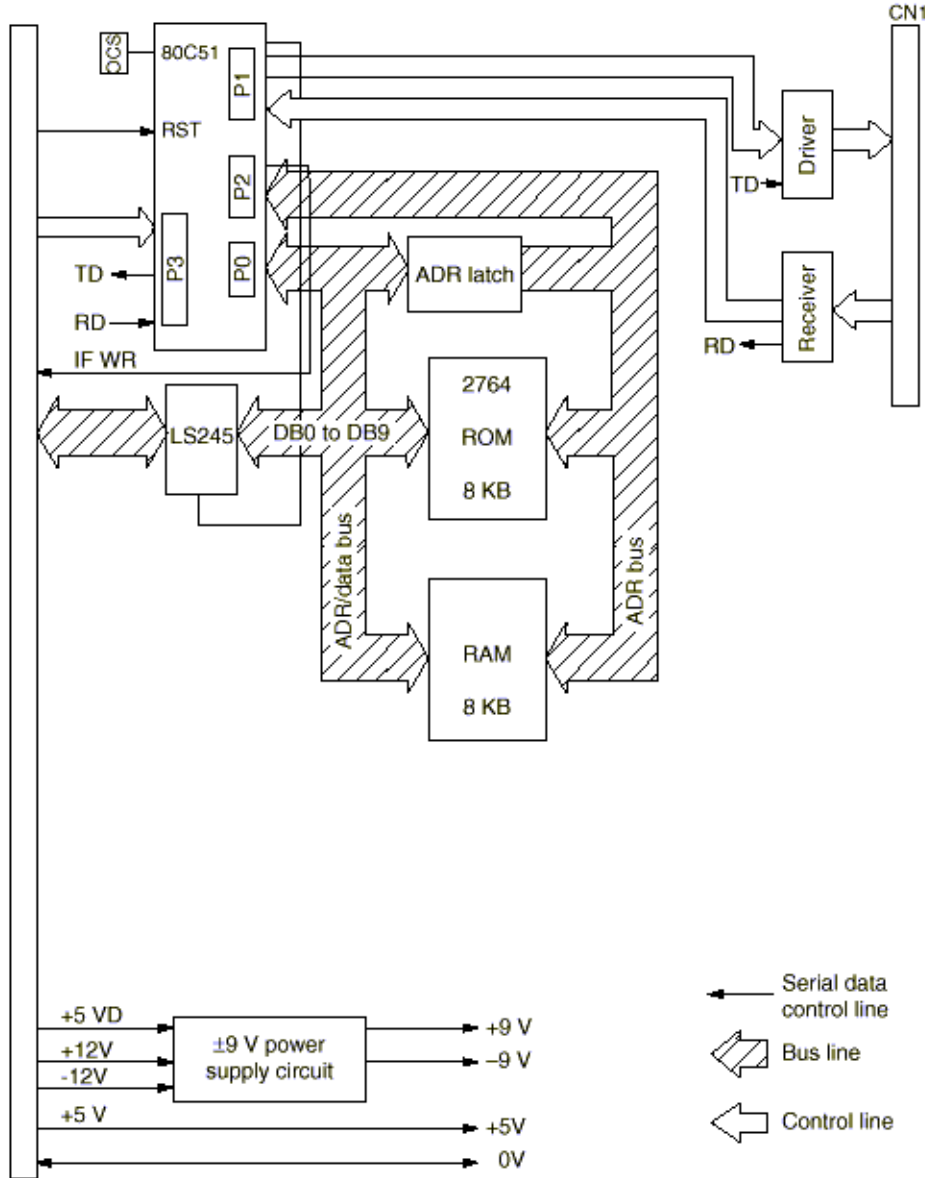

Figure B-2-1 Block Diagram



Service Guide for PM4410

Chapter B RS-232C Serial Interface Board

2.2.1 Operation at power on

After power is turned on, an RST OUT signal is sent from the printer control board to reset the printer. When the reset is canceled, the 80C51 CPU performs initialization. Initialization consists of setting the 80C51 timer, and setting the serial mode.

Copyright 1998, Okidata, Division of OKI America, Inc. All rights reserved. See the OKIDATA Business Partner Exchange (BPX) for any updates to this material. (<http://bpx.okidata.com>)



Service Guide for PM4410 Chapter B RS-232C Serial Interface Board

2.2.2. RS-232C interface

The DTR, SSD, TD and RTS signals output by the 80C51 are converted to RS-232C signals by line driver SN75188 (Q1) and sent to the interface.

In addition, signals DSR, CTS, CD, and RD on the RS232C interface are converted to TTL level by line receiver SN75189 (Q2) and input to the 80C51.

Copyright 1998, Okidata, Division of OKI America, Inc. All rights reserved. See the OKIDATA Business Partner Exchange (BPX) for any updates to this material. (<http://bpx.okidata.com>)



Service Guide for PM4410
Chapter B RS-232C Serial Interface Board

2.3 Local Test

2.3.1 Circuit test mode

Copyright 1998, Okidata, Division of OKI America, Inc. All rights reserved. See the OKIDATA Business Partner Exchange (BPX) for any updates to this material. (<http://bpx.okidata.com>)



Service Guide for PM4410
Chapter B RS-232C Serial Interface Board

2.3.1 Circuit test mode

2.3.1.1 Setting

2.3.1.2 Function

Copyright 1998, Okidata, Division of OKI America, Inc. All rights reserved. See the OKIDATA Business Partner Exchange (BPX) for any updates to this material. (<http://bpx.okidata.com>)

Service Guide for PM4410

Chapter B RS-232C Serial Interface Board

2.3.1.1 Setting

- (1) Diagnostic test (set by menu)
- (2) Test connector

Connect the test connector shown in Figure B-3-6 to the interface connector.

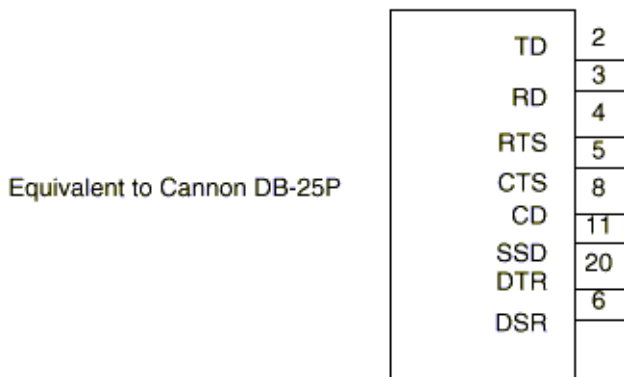

Figure B-3-6 Test Connector Connection Diagram



2.3.1.2 Function

After the settings outlined in Section 3.3.1.1 are completed and power is turned on, the serial interface checks the message buffer memory and interface driver/receiver circuit. It then prints characters.

To start and stop this test, push the SEL switch on the front of the printer. Details of this test are explained on the next page.

- (1) The program revision using two numerical characters is printed.
- (2) "LOOP TEST" is printed.
- (3) Memory is checked for the message buffer.
- (4) Prints "OK" is printed if the memory check is OK and "BAD" is printed if the memory check fails.
- (5) Output level to DTR, RTS, and SSD signals is dropped low. If DSR, CTS, or CD signals is High, "IF BAD" is printed. If DSR, CTS, and CD signals are all Low, "IF OK" is printed.
- (6) Output level to DTR, RTS, and SSD signals is raised high. If DSR, CTS, or CD signals is Low, "IF BAD" is printed. If DSR, CTS, and CD signals are all High, "IF OK" is printed.
- (7) Transmits characters codes from 20H to 7FH is transmitted by SD signal. At the same time, characters are received by the RD signal and stored in the message buffer.
- (8) The characters that were stored in the message buffer as indicated in (7) are printed.
- (9) Steps (1) through (8) are repeated until test is interrupted.



Service Guide for PM4410 Chapter C Maintenance Support Function

1. Normal mode

(1) DIP Switch Settings

DIP SWITCH	DIP SWITCH	DIP SWITCH	DIP SWITCH	Function
4	3	2	1	
-	-	-	-	Normal mode

(O: ON, X: OFF, -: ignored)

(2) Power ON Switch Function

SWITCH	SWITCH	SWITCH	SWITCH	SWITCH	SWITCH	SWITCH	SWITCH	Function
SEL/ RESET	MENU	CONFIG	PATH/ TOF	FF/LOAD	LF	TEAR	PARK	
	O							Starts menu m
	O	O						Starts menu m
					O			Starts demo-p:
			O					Starts rolling A
				O		O		Starts head pir
				O				Starts HEX DL

SWITCH	SWITCH	SWITCH	SWITCH	SWITCH	Function
GROUP	ITEM	OPTION	STORE	MENU	
O	O				Sets MENU setting CFG 1 to factory default. Note ⁽¹⁾
	O	O			Sets MENU setting CFG 2 to factory default. Note ⁽¹⁾
O		O			Sets paper input location to factory default.
		O	O		Sets MENU setting (CFG 1 and 2)/paper input location default. Note ⁽¹⁾
			O	O	Sets header/MENU settings CFG 1 and 2) to ROM fixed Sets paper input location to factory default.

Note ⁽¹⁾ Registration/flash ROM USED setting holds the values of current setting.



Service Guide for PM4410 Chapter C Maintenance Support Function

2. Maintenance mode 1

(1) DIP Switch Settings

DIP SWITCH	DIP SWITCH	DIP SWITCH	DIP SWITCH	Function
4	3	2	1	
-	-	O	-	Maintenance information indication enabled mode

(O: ON, X: OFF, -: ignored)

(2) Operator panel switch Function

SWITCH	SWITCH	SWITCH	SWITCH	SWITCH	SWITCH	SWITCH	SWITCH	Function (Valid)
ON-LINE	SHIFT	CONFIG	PATH/ TOF	FF/LOAD	LF	TEAR	PARK	
			O		O			Starts learning
					O		O	Starts auto-gap
				O	O			Gap open/clos
		O		O				Starts gap clos
			O			O		Starts ON/OFF
	O	O		O			O	Starts the align
						O	O	Resets the cou
					O	O		Starts AG corr
			O				O	Starts AG adju
O		O						Flash Loading
O	O							Starts aging m

The above switches are also valid during Limited Operation. The empty boxes indicates not-pressed switches. O: indicates that the swit



Service Guide for PM4410 Chapter C Maintenance Support Function

3. Maintenance mode 2

(1) DIP Switch Settings

DIP SWITCH	DIP SWITCH	DIP SWITCH	DIP SWITCH	Function
4	3	2	1	
-	-	O	-	Maintenance information indication enabled mode

(O: ON, X: OFF, -: ignored)

(2) Operator panel switch Function

SWITCH	SWITCH	SWITCH	SWITCH	SWITCH	SWITCH	SWITCH	SWITCH	Function (Valid)
ON-LINE	SHIFT	CONFIG	PATH/TOF	FF/LOAD	LF	TEAR	PARK	
O	O							The LCD display number, number

(3) Maintenance Information Display Condition

LCD / Condition	LCD / Condition	Flash ROM Function	Flash ROM Function
		Function	Display Data
Top line	1~8	Displays the value of line feed counter.	Current counter value
Top line	9~16	Displays the value of print counter.	Current counter value
Bottom line	1~8	Displays a correction value for AG centering.	Current counter value
Bottom line	9~16	Reserved	

(4) Stored historical page number data

This function counts a page each 11 inch and stores it to EEPROM.

The storage capacity for the counter is 3 byte which equals to pages for 70 years at 20000 pages/ month.

As the printer has no function which is capable of resetting this counter, line feed frequency can be known since the printer's shipment.

(5)

a) Stored historical printed character number data

This function counts the number of actually printed characters and stores it to EEPROM.

It reads and analyzes the characters from receiving buffer and identifies the characters which has been actually printed and counts them.

The count of image data for any DPI should be increases by one character each 12 columns,

The storage capacity for the counter is 3 byte which equals to 430 million characters with 256 characters counted as 1 count.

As the printer has the function which is capable of resetting this counter to zero, The usage frequency of print head ribbon can be known as an index by resetting this counter when replacing a print head and ribbon set.

b) Printed character number counter resetting function

Activating	Power on, holding SHIFT + CONFIG switches.
Releasing	
Condition	When DIP switch 1 has been turned on.
Subject	Printed character number counter (EEPROM data)

This function resets the counter for the number of printed characters to zero, which is stored in the EEPROM.

This function is advanced in the following steps.

1) This function starts, showing the following indications on the LCD.

Top line : INITIALIZING

Bottom Line : COUNTER RESET

2) It resets the printed character number counter to "0" and rewrites the EEPROM.

3) The printer returns to the normal Power On condition.

Copyright 1998, Okidata, Division of OKI America, Inc. All rights reserved. See the OKIDATA Business Partner Exchange (BPX) for any updates to this material. (<http://bpx.okidata.com>)



Service Guide for PM4410 Chapter C Maintenance Support Function

4. Maintenance function

The section has the following functions to help you service this printer.

Function name	Summarized description of function	Subject
Sensor slice level learning function	Sets the optimum slice level values for sensors.	Paper width sensor
All sensor ON/OFF check function	Checks ON/OFF switching of all the sensors.	Lower PE sensor Upper PE sensor Front PE sensor Rear PE sensor Tractor switching sensor Bail sensor Paper width sensor Paper JAM sensor Ribbon disengagement sensor Ribbon JAM sensor Cover open sensor
Head pin test	Checks if head pin is broken	18 pin head
Auto gap test	Performs auto gap motion 100 times	Gap mechanism
Gap close	Shifts the gap to the 1p position	Gap
Print start position PE sensor aligning function	Detects the position of installed PE sensor for the correction of distance towards print start position.	Print start position PE sensor
FLASH loading function	Enables memory to be loaded to the FLASH ROM.	FLASH ROM
AG correction function	Measures AG pushdown for 3 times, which is the number of pushdown slits from the position 210 slits away from the slit edge and prints each measured value and the average value. Also, stores the average value to EEPROM, which is defined as a reference of AG correction value.	AG
AG adjustment aid function	Displays such values on the LCD as : 1. frequency at 370PPS (the number of slit counts), 2. the number of slit counts from the slit edge to delta f, 3. the number of pushdown slit counts from delta f, (delta f1+10).	AG
Menu default value loading function	Rewrites the menu default values stored in the EEPROM by a provided command.	Menu default value
Print header loading function	Rewrites the data of the print header by a provided command	Print header data
Head temperature alarm detection mode setting function	Indicates the fact that head temperature alarm has been detected on the printed output as a record	Head temperature
Gap open/close test	Performs 100 cycles of full open/1p close of gap.	AG
Aging	Performs a 10 min. or 5 min. continuous aging.	Mechanism

4.1 Auto gap test

4.2 Gap close

4.3 Sensor slice level learning function.

4.4 All sensors ON/OFF check function

4.5 Print start position PE sensor aligning function

4.6 FLASH memory loading function

4.7 Head pin test

4.8 AG correction function

4.9 AG adjustment aid function

4.10 Autogap Open/Close Test

4.11 Aging Function

Copyright 1998, Okidata, Division of OKI America, Inc. All rights reserved. See the OKIDATA Business Partner Exchange (BPX) for any updates to this material. (<http://bpx.okidata.com>)



Service Guide for PM4410

Chapter C Maintenance Support Function

4.1 Auto gap test

Activating	Power the printer on while holding the LF+PARK switches.
Releasing	It automatically ends at power off.
Condition	When DIP switch has been turned on.
Subject	Gap mechanism

Use this function to perform an aging on auto gap mechanism.

This function is advanced in the following steps.

(1) This function starts, showing the following indications on the LCD.

Top line: ADJUSTMENT

Bottom line: AUTO GAP

(2) It provides auto gap motions at least 100 times with every motion waiting approx. 500 ms until the next motion.

(3) The printer returns to normal condition after initialization.



Service Guide for PM4410

Chapter C Maintenance Support Function

4.2 Gap close

Activating	Power the printer on while holding the CONFIG+FF switches.
Releasing	It automatically ends at power off.
Condition	When DIP switch has been turned on.
Subject	Gap mechanism

Use this function to make a shift to gap 1P position.

This function is advanced in the following steps.

(1) This function starts, showing the following indications on the LCD.

Top line: ADJUSTMENT

Bottom line: AUTO CLOSE

(2) It makes a shift to 1P position.

(3) The printer returns to normal condition after initialization.



Service Guide for PM4410 Chapter C Maintenance Support Function

4.3 Sensor slice level learning function

Activating	Power the printer on while holding the PATH+LF switches.
Releasing	It automatically ends at power off.
Condition	When DIP switch has been turned on.
Subject	Gap mechanism

Sets appropriate resistance values/slice level by using this function and store them to the EEPROM.

(1) This function starts, showing the following indications on the LCD.

Top line: ADJUSTMENT

Bottom line: OPTICAL SENSOR

(2) LCD shows the following indication after the completion of the function.

Top line: ADJUSTMENT

Bottom line: OPTICAL SENSOR

(2) LCD shows the following indication after the completion of the function.

Top line: ADJUSTMENT

Bottom line: COMPLETE (when the resistance values/slice level setting have been normally and successfully determined).

Bottom line: FAIL (no appropriate level can be detected in each detection (paper left, no paper left)).



Service Guide for PM4410

Chapter C Maintenance Support Function

4.4 All sensors ON/OFF check function

Activating	Power the printer on while holding the PATH+TEAR switches.
Releasing	Power off.
Condition	When DIP switch 1 has been turned on.
Subject	Various PE sensors, paper width sensor, paper JAM sensor, ribbon JAM sensor, tractor switching sensor, bail sensor and cover open sensor.

This function detects each sensor switching condition and displays the name of the switched sensor for about 500ms, notifying the operator that the sensor is active.

This function is advanced in the following steps.

(1) This function starts, showing the following indication on the LCD.

Top line: SENSOR TEST

Bottom line: blank

(2) It always monitors each sensor switching condition and when detecting a change, displays the name of the sensor for about 500ms or more at the bottom line of the LCD.

(3) Initialize the setting by pressing SHIFT+SEL (RESET) switches and returns the printer to normal condition.



Service Guide for PM4410 Chapter C Maintenance Support Function

4.5 Print start position PE sensor aligning function

Activating	Power the printer on while holding the FF+PARK switches.
Releasing	Power off.
Condition	When DIP 1 switch has been turned on.
Subject	Print start position PE sensor

This function measures and saves the distance between paper width sensor and print start position PE sensor for improving the accuracy of print start position on papers. This function is advanced in the following steps.

(1) This function starts, showing the following indication on the LCD.

Top line: ADJUSTMENT

Bottom line: PE SENSOR POS

(2) When the function successfully finishes the measuring operation, the printer notifies of the normally completed motion by showing the function indications on the LCD.

Top line: ADJUSTMENT

Bottom line: COMPLETE

(3) In the case of the measurement being abnormally performed (or when input jam or park jam occurs), the function will not update the distance between PE sensor and paper width sensor, showing the following indications on the LCD.

Top line: ADJUSTMENT

Bottom line: FAIL

(4) Initialize setting and return the printer to normal condition after the above steps.



Service Guide for PM4410

Chapter C Maintenance Support Function

4.6 FLASH memory loading function

Activating	Power the printer on while holding the PATH+PARK switches.
Releasing	Power off.
Condition	In case the setting is enable in "FLASH LOADING" menu.
Subject	FLASH ROM

This function shifts the printer to the program loading mode to the FLASH ROM, so the memory can be loaded to the FLASH ROM by FLASH loading command.

The loading to the flush ROM should be performed in the following steps.

- (1) Set the Flash Loading item to be Enable in the Technical group of menu.
- (2) Power the printer on while holding the press PATH and PARK switch. (LCD reads Flash Loading Mode).
- (3) Send data with the command for changing Flash memory contents (ESC DLE L pl m1 m2...).
- (4) Transmit the command to stop changing Flash memory contents (ESC DLE M p1).
- (5) Give the printer an ordinary power-on after the receiving of the stop command shifts is to Flash Loading Mode End.

Have the printer operate according to the contents loaded in the Flash memory.

- (1) Set the Flash ROM Used item at Yes in the Technical group of menu.
- (2) Re-power the printer on.



Service Guide for PM4410

Chapter C Maintenance Support Function

4.7 Head pin test

Activating	Power the printer on while holding the FF+PARK switches.
Releasing	Power off.
Condition	n/a
Subject	Head pin

Use this function to perform such printing as uses all the printing head pins to determine whether there is any broken pin or not.

This function is advanced in the following steps.

(1) This function starts, showing the following indication on the LCD.

Top line: SELFTEST

Bottom line: PIN PATTERN

(2) The printer prints the header of model name and so on, and then sequentially prints Head A Group #1, Head B Group #1, Head A Group #2, Head B Group #2 Head A group #9, Head B Group #9 to check if any of them is broken or not.

PM4410 MEI A FWxx.xx xxxxxxxxYR-xx								
CGxx.xx								
<1>	<2>	<3>	<4>	<5>	<6>	<7>	<8>	<9>
								↑↑

The behind pin of #9 - The ahead pin of #9

(3) Uses a pseudo 120DPI image for printing as its print mode.

(4) Initialize the setting and return the printer to normal condition after the completion of the printing.



Service Guide for PM4410

Chapter C Maintenance Support Function

4.8 AG correction function

Activating	Power the printer on while holding the TEAR+PARK switches.
Releasing	The measurement ends at power off.
Condition	When DIP switch 1 has been turned on.
Subject	AG

This function corrects and indicates AG control values.

This function is advanced in the following steps.

(1) This function starts, showing the following indications on the LCD.

Top line: ADJUSTMENT

Bottom line: AG DETECT DATA

(2) Pressing FF/LOAD switches will start the paper feed. At this time, the weight of paper set is to be 55kg.

(3) The printer performs AG for 3 times.

(4) The printer prints the pushdown slit number from "the position 210 slits away from the slit edge" each AG operation and the average slit number in the following format.

(The slit number at the first time) xxxH (HEXADECIMAL NUMBER)

The slit number at the second time) xxxH (HEXADECIMAL NUMBER)

The slit number at the third time) xxxH (HEXADECIMAL NUMBER)

(The average slit number) xxxH (HEXADECIMAL NUMBER)

But if the Auto Select has not been set to the Valid in the menu, press the ON-LINE switch after paper feed.

(5) Store the average slit number to the EEPROM, which will be used as a "return amount" from the paper surface at a future AG operation.

(6) If the average slit number is 11 counts or less, or 34 counts or more, the printer displays a warning indication and stops the function. (Sets the average count number invalid and stores default value (22 counts) to the EEPROM as a "return amount".)

Top line: ADJUSTMENT

Bottom line: WARNING

(7) If the average slit number is 12 ~ 33 counts, the printer will show a normal completion of the operation on the LCD and finishes this function.

Top line: ADJUSTMENT

Bottom line: COMPLETE

(8) The initial value of "return amount" is to be 22 counts.

Copyright 1998, Okidata, Division of OKI America, Inc. All rights reserved. See the OKIDATA Business Partner Exchange (BPX) for any updates to this material. (<http://bpx.okidata.com>)

4.9 AG adjustment aid function

Activating	Power the printer on while holding the LF+TEAR switches.
Releasing	Power off and press the reset Switch.
Condition	When DIP switch 1 has been turned on.
Subject	AG

This function indicates the information which helps AG adjustment.

(1) This function starts, showing the following indications on the LCD.

Top line: ADJUSTMENT

Bottom line: AG DATA DISPLAY

(2) The following information about the executed AG detection is shown on the LCD, which can be held until the next AG detection.

Also, an error reaching nearly one slit may occur in the number of slit counts

Top line: ADJUSTMENT

Bottom line:

- 1 ~ 2 characters: Average head correction value.
- 3 ~ 4 characters: the range of gaps.
- 5 ~ 8 characters: the slit count number at 370PPS (A).
- 9 ~ 10 characters: the slit counter number from the slit edge to delta f (B).
- 11 ~ 12 characters: the pushdown slit count number from delta f (delta f+10) (C).
- 13 ~ 16 characters: Head position

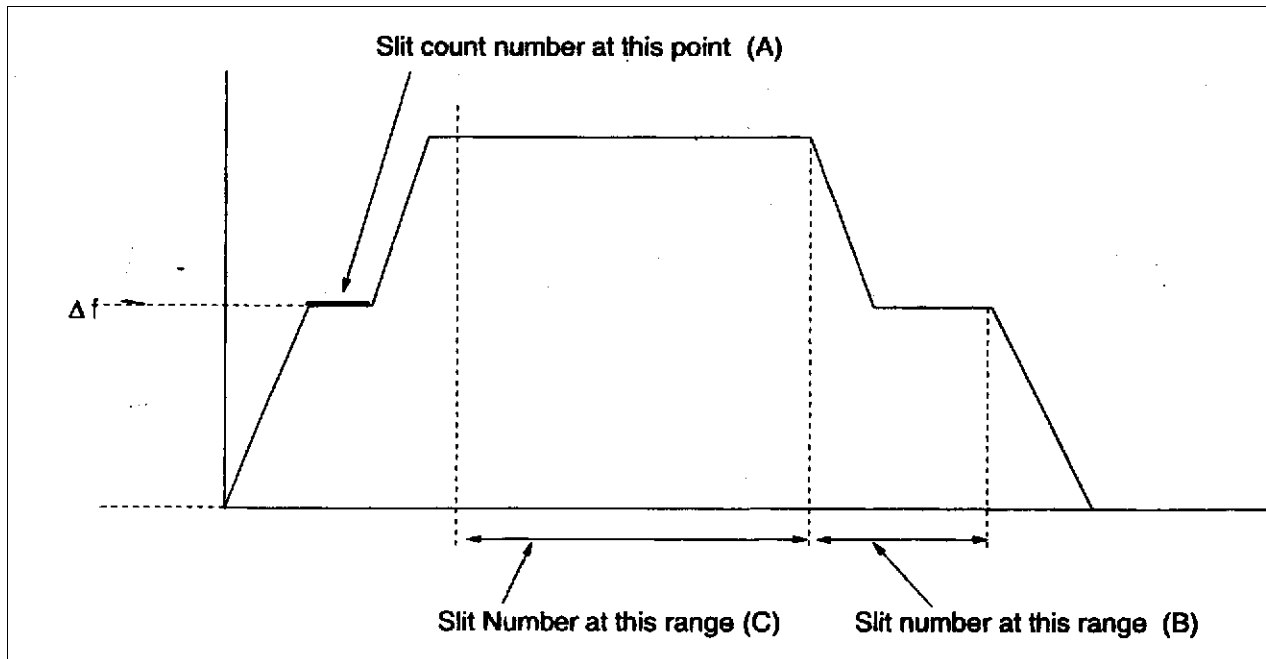

(3) This function itself cannot perform AG detection. Therefore, it is necessary to make the printer perform such a motion as paper input and so on which will induce an AG detection, and check the indication of the results. (But the printer makes the interface to be BUSY, which results in data receiving and printing being impossible).

Copyright 1998, Okidata, Division of OKI America, Inc. All rights reserved. See the OKIDATA Business Partner Exchange (BPX) for any updates to this material. (<http://bpx.okidata.com>)



Service Guide for PM4410 Chapter C Maintenance Support Function

4.10 Autogap Open/Close Test

Start up	Power the printer on while holding the LF+FF/LOAD switches.
Releasing	Completion of execution.
Condition	DIP switch should be turned to ON position.
Target	Gap mechanism.

This function performs the aging to the autogap mechanism.

This function is executed according to the following procedure.

(1) The LCD displays the following messages, informing of the start of this function.

Top line: ADJUSTMENT

Bottom line: AG OPEN/CLOSE

(2) On condition that papers are loaded, the following motions will be repeated 100 times.

Full open motion: 1P close motion 500us weight

(3) After initialization, the printer returns to normal state.



Service Guide for PM4410

Chapter C Maintenance Support Function

4.11 Aging Function

Start up	Power the printer on while holding the ON-LINE+CONFIG switches (aging time: 10 min.), or power the printer on while holding the ON-LINE+SHIFT switches (aging time: 5 min.).
Releasing	Lapse of either time. ON-LINE SW pressed.
Condition	DIP switch should be turned to ON position.
Target	Mechanism

This function is executed according to the following procedure.

(1) The LCD displays the following messages, informing of the start of this function.

Top line: ADJUSTMENT

Bottom line: Aging

(2) Spacing is performed from 0 to 13.6" at 96.6IPS. (Without LF motion).

(3) This function ends after a lapse of 10 min. or 5 min. (From the viewpoint of control, the number of spacing cycles is used).